

SNL plummer block housings

solve housing problems





The SKF brand now stands for more than ever before, and means more to you as a valued customer.

While SKF maintains its leadership as a high-quality bearing manufacturer throughout the world, new dimensions in technical advances, product support and services have evolved SKF into a truly solutions-oriented supplier, creating greater value for customers.

These solutions enable customers to improve productivity, not only with breakthrough application-specific products, but also through leading-edge design simulation tools and consultancy services, plant asset efficiency maintenance programmes, and the industry's most advanced supply management techniques.

The SKF brand still stands for the very best in rolling bearings, but it now stands for much more.

SKF – the knowledge engineering company

Contents

A Product information

3 Fewer bearing replacements and less maintenance

- 3 Plummer block housings have much to offer
- 3 SNL plummer block housings have more to offer
- 4 One basic design – many variants
- 6 Features and benefits
- 8 Superior performance in all sectors

B Recommendations

10 Bearing arrangement design

- 10 Bearings on adapter sleeves on straight shafts
- 11 Bearings on adapter sleeves on stepped shafts
- 12 Bearings on withdrawal sleeves on stepped shafts
- 13 Bearings on cylindrical seats on stepped shafts
- 14 Standard seals
- 21 Special seals
- 22 End covers
- 22 Locating rings
- 24 Axial displacement using CARB toroidal roller bearings in SNL housings

26 Application advice for trouble-free operation

- 28 Lubrication
- 32 Mounting
- 36 Mounting SNL housings with four-lip seals
- 38 Mounting SNL housings with double-lip seals
- 40 Mounting SNL housings with V-ring seals
- 42 Mounting SNL housings with felt seals
- 44 Mounting SNL housings with labyrinth seals
- 43 Mounting SNL housings with taconite seals
- 48 Mounting SNL housings with oil seals

C Product data

50 Designations and housing data – general

- 50 Designations
- 50 Load carrying ability

56 Product tables

- 56 SNL plummer block housings for bearings on an adapter sleeve, metric shafts
- 68 SNL plummer block housings for bearings on an adapter sleeve, inch shafts
- 84 SNL plummer block housings for bearings with a cylindrical bore
- 94 Sealing arrangements for SNL plummer block housings

D Additional information

100 Other products for trouble-free operation

- 100 High-performance, self-aligning standard bearings
- 101 For easy mounting – adapter and withdrawal sleeves
- 102 Other products
- 103 Other bearing housings
- 104 Condition monitoring equipment

106 SKF – the knowledge engineering company

Fewer bearing replacements and less maintenance

Plummer block housings have much to offer

The main benefit of split plummer block housings is their easy installation; preassembled shafts can be mounted in them. When the housing bases are attached to the base plate, it is then only necessary to place the housing caps in position and to tighten the attachment bolts to complete the installation.

Split plummer block housings available on the market are mainly intended for self-aligning ball bearings, spherical roller bearings and CARB toroidal roller bearings of ISO Dimension Series 02, 03, 22, 23 and 32. They can often be fitted with a number of different seals. Many designs and variants of split plummer block housings are available, making the use of tailored housings unnecessary and thus enabling cost-effective bearing arrangements to be made.

For many years SKF has been one of the leading producers of split plummer block housings – synonymous with operational reliability, quality and versatility.

SNL plummer block housings have more to offer

SKF has developed the SNL plummer block housings to be the first choice for design, quality and economy. This enables customers to keep a step ahead.

SNL plummer block housings enable the full service life potential of the incorporated bearings to be exploited with less need for maintenance. This supports user's efforts to further reduce maintenance costs. Among other characteristics, the housings are very stiff, making them insensitive to uncontrolled and excessive tightening of the attachment bolts.

Another benefit is the wide range of different types of standard seals to be fitted in the SNL plummer block housings.



One basic design – many variants

SNL plummer block housings are primarily intended for self-aligning ball bearings, spherical roller bearings and CARB toroidal roller bearings. The housings are designed on the “building block” principle to enable a wider choice of bearings and seals as well as a variety of mounting and lubrication methods.

A building block system

The SKF assortment of SNL plummer block housings can accommodate shafts ranging from 20 to 160 mm in diameter. These housings, which all share the same design features, are available with a variety of seals. The standard range also includes a number of options, like tapped holes for grease fittings and condition monitoring sensors, to create an almost limitless combination of variants. Housings are also available for bearings for larger shaft diameters (→ **page 103**).

SNL plummer block housings are made of high quality, grey cast iron to provide high tensile strength. For applications where additional strength is required, housings made of spheroidal graphite cast iron are available.

Several sealing options

An important advantage of the SNL plummer block housings is that they can be fitted with a variety of seals. Standard SKF seals include four-lip seals, V-ring seals, felt seals, labyrinth seals and heavy-duty taconite labyrinth seals with a radial labyrinth and end covers. Other standard seals are also available for SNL housings, but the housing has to be modified for the seal to be effective. These include oil seals and heavy-duty taconite labyrinth seals with an axial labyrinth.

SNL plummer block housings are dimensionally interchangeable with the earlier SNH housings. Their dimensions conform to ISO 113:1999.



Features and benefits

The SKF assortment of SNL plummer block housings is characterized by a number of advantages, including high load carrying capacity and machining quality. In addition, SNL housings incorporate unique features that are designed to improve the performance and increase the service life of your application.

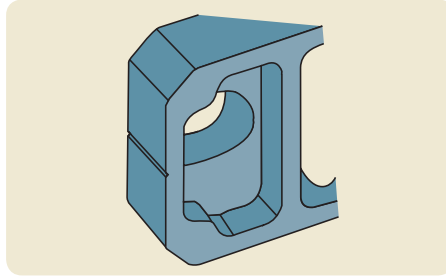

Stiff design

The housing base is reinforced with ribs and extra material around the attachment holes to add strength and prevent deformation of the base. The attachment bolts can be preloaded to locate the housing and prevent deformation of the housing base and bore.

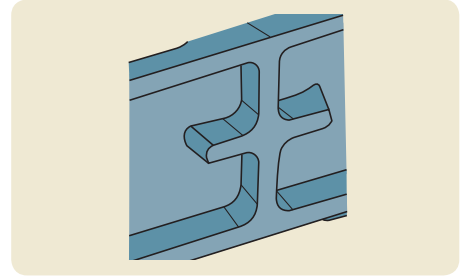

Excellent heat conduction

Additional ribs on the underside of the base improve heat flow from the bearing outer ring to the support surface. Bearings in an SNL housing run 5–10 % cooler than the bearings in other housings.

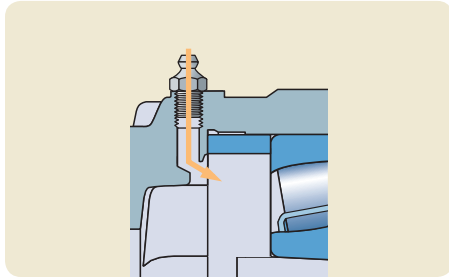

Grease guiding system

When lubricating from the top, this feature guides fresh grease from the fitting to the side of the bearing. This applies in particular for lubricating self-aligning ball bearings and CARB bearings.

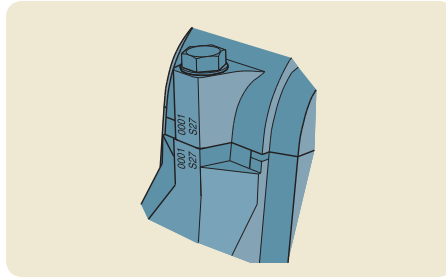

Caps and bases individually marked

The housing base and cap are matched during manufacture and are not interchangeable with the caps and bases of other housings. To prevent any mismatches, a unique serial number is marked on both the housing cap and base.

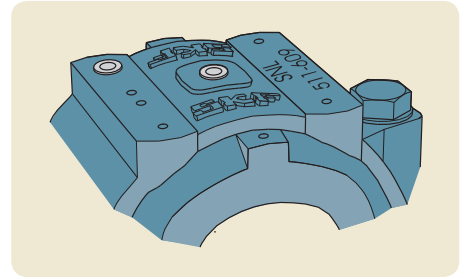

Relubrication made simple

Standard SNL housings have two tapped holes in the cap for the grease fitting. They are protected by plastic plugs. The location of the grease fitting is determined by the bearing. If the bearing has a W33 groove, install the fitting in the middle of the housing. Otherwise, put the fitting in the other hole so that grease will enter the bearing from the side.

- Stiff design Insensitive to over-tightening of the attachment bolts
- Excellent heat dissipation Lowers bearing operating temperature
Extends relubrication intervals
Increases the service life of the bearings, seals and lubricant
- Drilled and tapped holes for grease fittings Relubrication facility as standard
- Caps and bases individually marked Avoids mixing caps and bases, enables traceability
- Dimples cast into the housing to identify drilling locations Enables quicker adaptation of a standard housing to an application
- Simple mounting Centre lines are cast into the housing base to simplify the alignment process
- Additional seals Several sealing options, to extend bearing service life in harsh operating environment
- Grease guiding system Guides grease directly to the side of the bearing

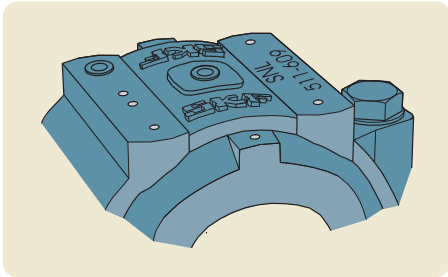

Dimples to locate accessories

SNL housings have dimples cast into the housing cap to show where condition monitoring sensors can be mounted for maximum effectiveness.

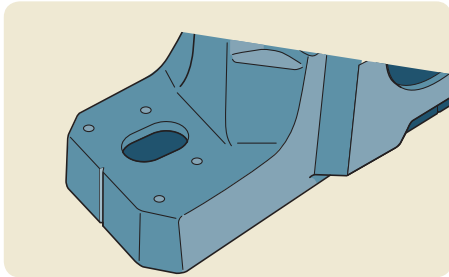

Simple mounting

To simplify mounting and make alignment more accurate, lines indicating the centre of the bore and the centre of the base are cast into the housing. Mounting instructions, included with each seal pack, provide valuable installation tips.

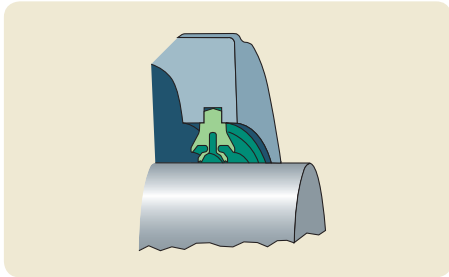

High speed seal

The SKF four-lip, low friction seal was developed specifically for SNL housings. This highly effective seal, which can accommodate speeds up to 13 m/s, is easy to remove and install.

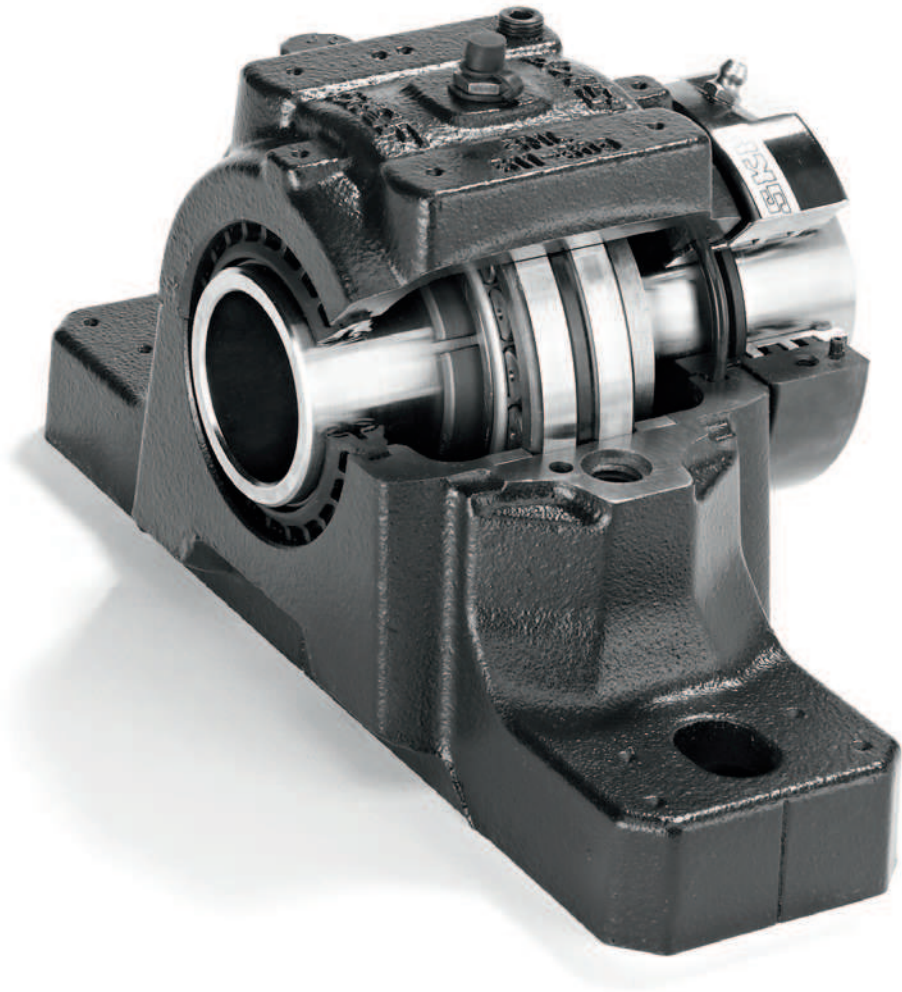

Superior performance in all sectors

High load carrying capacity, robust design, accurately machined surfaces and simplified installation make SKF housings the first choice for machine manufacturers and end users.

Another reason why SKF housings are so popular is because knowledgeable consumers know that high quality components can significantly reduce operating costs – that includes everything from maintenance, energy consumption, lubricant consumption and downtime.

Applications

- Mine ventilators
- Exhaust and fresh air fans
- Flue gas fans
- Emergency power supply generator flywheels
- Transmissions
- Belt drives
- Impact and hammer mills

Customer demands

- Robust design
- No breakdowns
- Extremely effective seals
- Long maintenance intervals
- Condition monitoring facilities
- Fast and easy mounting and dismounting

Solution





A

Bearing arrangement design

SNL plummer block housings are typically used with self-aligning ball bearings, spherical roller bearings or CARB toroidal roller bearings fitted on straight or stepped shafts; the bearings can be mounted on adapter or withdrawal sleeves or directly on cylindrical shaft seats. These housings can also be used with other bearing types if they are within the correct Dimension Series.

1. Bearings on adapter sleeves on straight shafts

Advantages

- Drawn round bar (tolerance h9) can be used without machining.
- Maximum shaft strength as there is no weakening by shoulders or reliefs.
- Bearings can be mounted at any position on the shaft.
- Mounting force, i.e. the force required to drive the bearing onto the sleeve, is 40 % less than with other shafts because there is only one sliding surface.
- Bearing radial clearance can be adjusted (within limits) during mounting to meet application demands.

Applications

- Bearing arrangements for relatively long shafts where more than two bearings are required for support.
- Bearing arrangements where machine components are mounted using wedging or tensioning components that do not require the shaft to be machined.
- Bearing arrangements where the final position of the bearing cannot be accurately determined.

Bearings on adapter sleeves on straight shafts

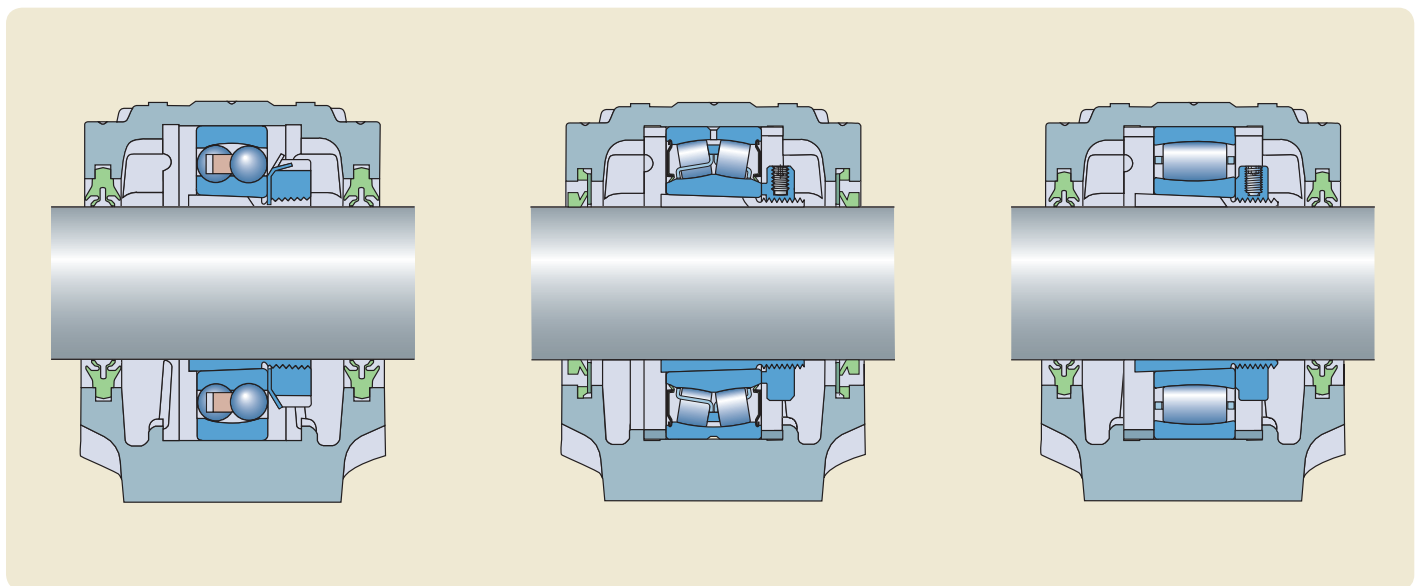

SNL 5

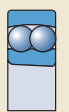

12 EK

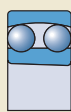

22 EK



222 EK

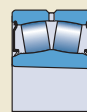

BS2-22-2CSK



232 CCK

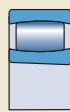

C 22 K

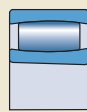

C 32 K

SNL 6

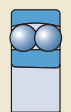

13 EK

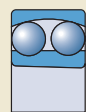

23 EK

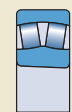

213 CCK

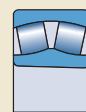

223 EK

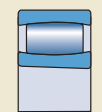

C 23 K

2. Bearings on adapter sleeves on stepped shafts

Advantages

- The bearing position on the shaft is accurately determined by the abutment ring.
- Other components on the shaft can be axially located by the bearing on its sleeve via spacer sleeves.
- Easy dismounting as the bearing inner ring is in contact with the abutment ring.
- Bearing radial clearance can be adjusted (within limits) during mounting to meet application demands.

Applications

- Bearing arrangements at the end of a shaft.
- Bearing arrangements where frequent mounting and dismounting are required.

Bearings on adapter sleeves on stepped shafts

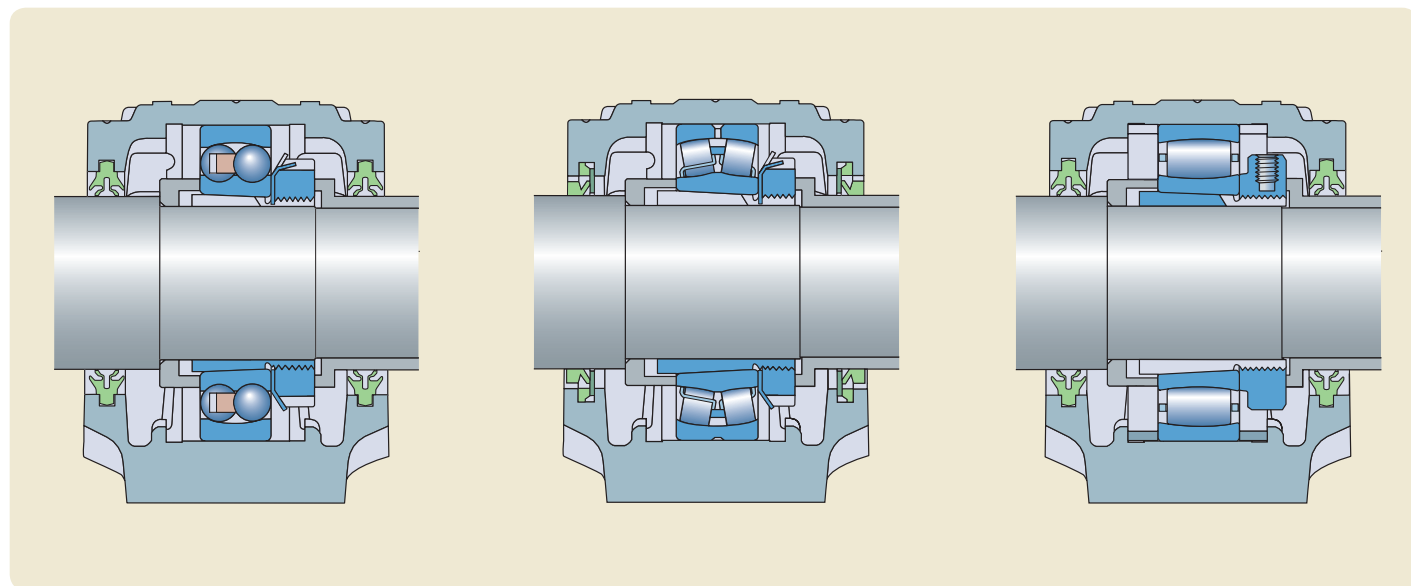

SNL 5

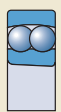

12 EK

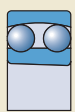

22 EK

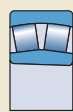

222 EK



BS2-22-2CSK

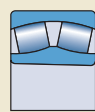

232 CCK

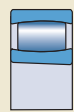

C 22 K

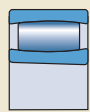

C 32 K

SNL 6

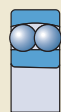

13 EK

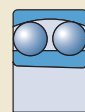

23 EK

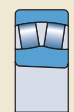

213 CCK

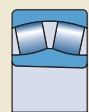

223 EK

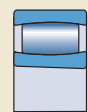

C 23 K

3. Bearings on withdrawal sleeves on stepped shafts

Advantages

- The bearing position on the shaft is accurately determined by the shaft shoulder.
- Other components on the shaft can be axially located by the bearing on its sleeve via spacer sleeves.
- Easy dismounting using a withdrawal or hydraulic nut.
- Bearing radial clearance can be adjusted (within limits) during mounting to meet application demands.

Applications

- Bearing arrangements at the end of a shaft.
- Bearing arrangements where frequent mounting and dismounting are required.

Bearings on withdrawal sleeves on stepped shafts

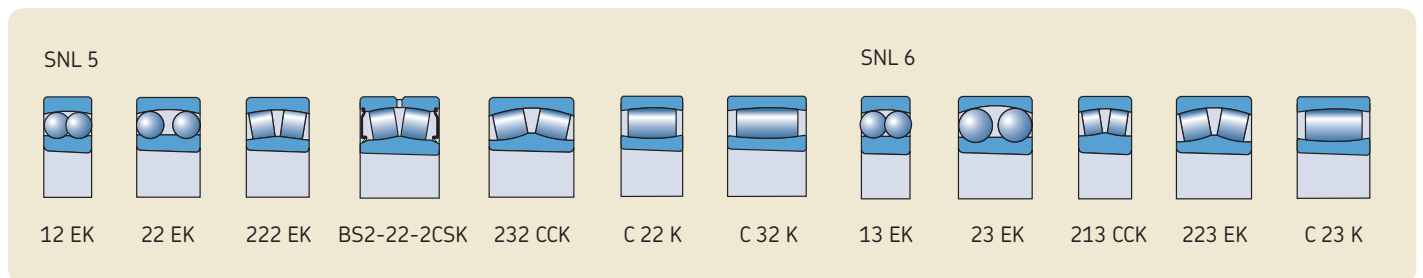
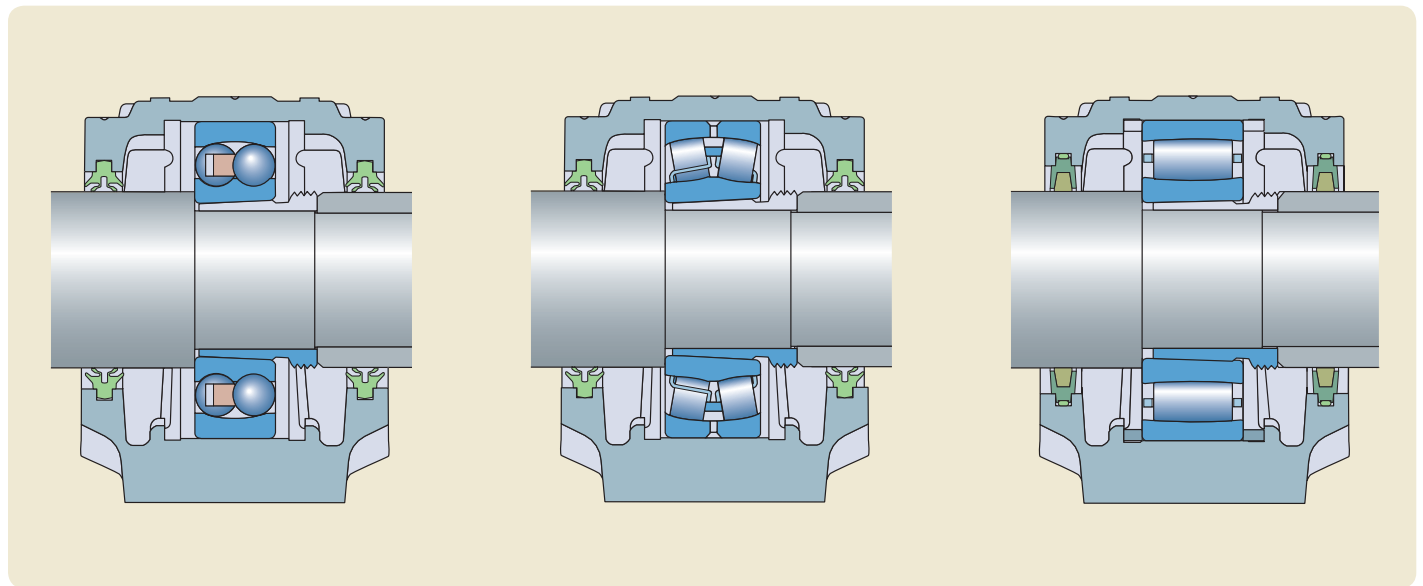

4. Bearings on cylindrical seats on stepped shafts

Advantages

- The axial load carrying capacity of the bearings (in both directions) is not limited by a sleeve.
- The residual bearing internal clearance is determined by the tolerance of the shaft seat so there is no danger of radially preloading the bearing during mounting.
- The bearing position on the shaft is accurately determined by the shaft shoulder.
- The bearing can be supported by other components via spacer sleeves.
- The shaft diameter at the bearing position is maximized.

Applications

- Bearing arrangements where large numbers of bearings have to be mounted.
- Bearing arrangements where large shock loads can occur.

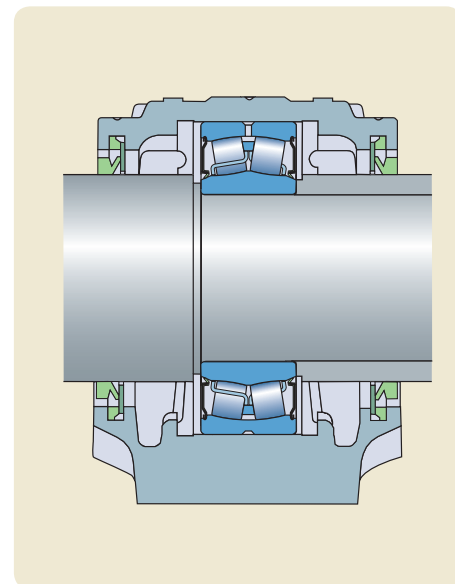

B

Bearings on cylindrical seats on stepped shafts

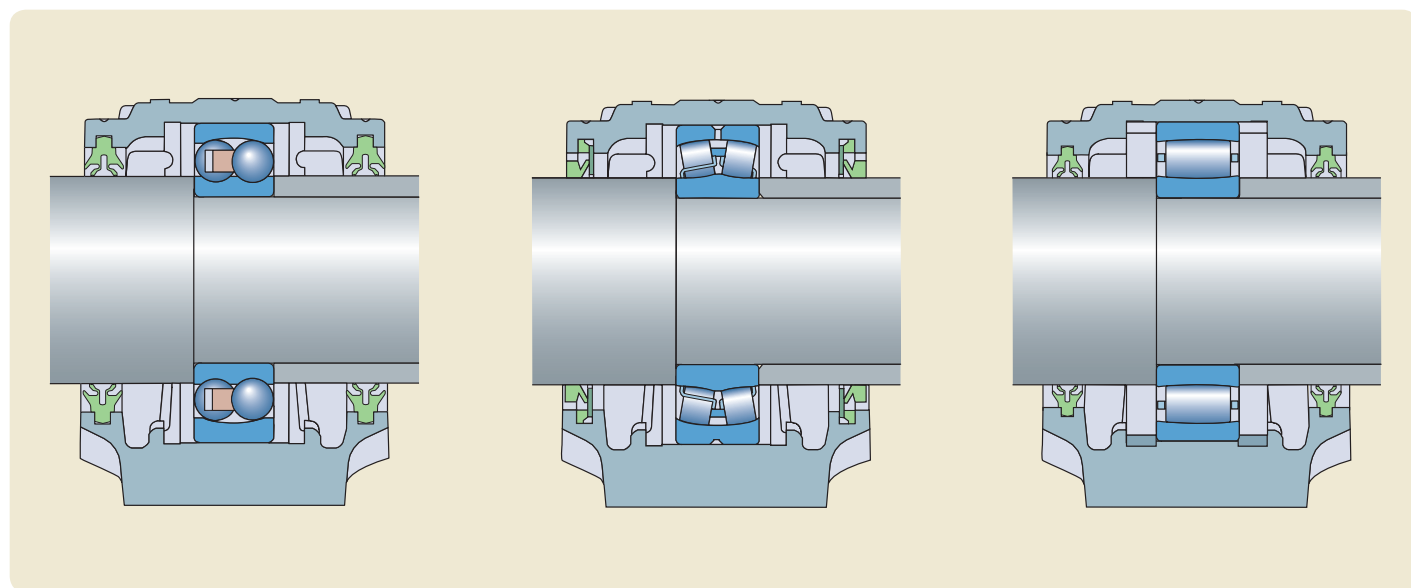

SNL 2

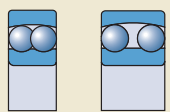

12 E

22 E

222 E

BS2-22-2CS

232 CC

C 22

C 32

SNL 3

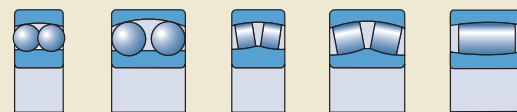

13 E

23 E

213 CC

223 CC

C 23

Standard seals

about standard and special seals can be found on **pages 16 to 21**.

An important advantage of SNL plummer block housings is that they can be fitted with different types of seals. Standard SKF seals include split four-lip seals, V-ring seals, felt seals, labyrinth seals and heavy-duty “taco-nite” seals with a radial labyrinth. The seals are easy to install and are supplied separately.

All the standard seals, as well as the seals for use with oil lubrication, are shown in **table 1**, with an overview of the seal type, its design features and suitability for various operating conditions. Detailed information

Table 1

Seal selection						
	TSN .. L	TSN .. A	TSN .. C	TSN .. S	TSN .. ND	TSN .. U ¹⁾
Internal conditions						
Temperature, °C	-40 to +100	-40 to +100	-40 to +100	-50 to +200	-40 to +100	-40 to +200
Temperature, °F	-40 to +210	-40 to +210	-40 to +210	-60 to +390	-40 to +210	-40 to +390
Peripheral speed, m/s ²⁾	up to 13	up to 7 above 7 ³⁾	up to 4	++	up to 12	++
Misalignment, degrees	0,5 to 1	1 to 1,5	up to 0,5	up to 0,3	up to 0,5	up to 1
Grease lubrication	++	++ ⁴⁾	-	+	+	-
Oil lubrication	--	--	--	--	--	++
Low friction	++	++	-	++	+	++
Axial shaft displacement	++	-	++	+	+	-
Vertical arrangement	+	++ ⁵⁾	--	--	-	--
Replacement	++	-	+	-	-	-
External conditions						
Dust	++	+	+	+	++	-
Fine particulate contaminants	++	+	-	+	++	+
Coarse particulate contaminants	+	-	-	+	++	+
Abrasive contaminants	+	--	+	++	++	++
Liquids when sprayed	+	+	-	--	++	-
Direct sunlight	+	--	++	++	++	++
						Symbols: ++ very suitable + suitable - limited suitability -- unsuitable
¹⁾ Delivered as a complete unit only, i.e. housings with seals, SNL .. TURU. Oil seals can be ordered separately as spare parts only ²⁾ See table 2 on page 15 to convert peripheral speeds to rotational speeds ³⁾ When the V-ring is axially supported ⁴⁾ If appropriate components are used; i.e. ASNA .. V end cover at the end of a shaft ⁵⁾ When the V-ring of the lower seal is mounted inboard						

Table 2

Rotational speeds corresponding to peripheral speeds						
Shaft diameter at the seal lip	Rotational speeds corresponding to peripheral speeds of					
$d_a, d_b^{1)}$	2 m/s	4 m/s	7 m/s	8 m/s	12 m/s	13 m/s
mm	r/min					
20	1 910	3 820	6 680	7 640	11 460	–
25	1 530	3 060	5 350	6 110	9 170	–
30	1 270	2 550	4 460	5 090	7 640	8 280
35	1 090	2 180	3 820	4 370	6 550	7 090
40	950	1 910	3 340	3 820	5 730	6 210
45	850	1 700	2 970	3 400	5 090	5 520
50	760	1 530	2 670	3 060	4 580	4 970
55	690	1 390	2 430	2 780	4 170	4 510
60	640	1 270	2 230	2 550	3 820	4 140
65	590	1 180	2 060	2 350	3 530	3 820
70	550	1 090	1 910	2 180	3 270	3 550
75	510	1 020	1 780	2 040	3 060	3 310
80	480	950	1 670	1 910	2 860	3 100
85	450	900	1 570	1 800	2 700	2 920
90	420	850	1 490	1 700	2 550	2 760
95	400	800	1 410	1 610	2 410	2 610
100	380	760	1 340	1 530	2 290	2 480
110	350	690	1 220	1 390	2 080	2 260
115	330	660	1 160	1 330	1 990	2 160
120	320	640	1 110	1 270	1 910	2 070
125	310	610	1 070	1 220	1 830	1 990
130	290	590	1 030	1 180	1 760	1 910
135	280	570	990	1 130	1 700	1 840
140	270	550	950	1 090	1 640	1 770
145	260	530	920	1 050	1 580	1 710
150	250	510	890	1 020	1 530	1 660
155	250	490	860	990	1 480	1 600
165	230	460	810	930	1 390	–
175	220	440	760	870	1 310	–

¹⁾ d_a : shaft diameter for bearings on an adapter sleeve. d_b : shaft diameter for bearings on a stepped shaft

Four-lip seals

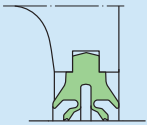
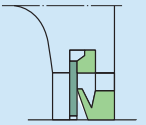
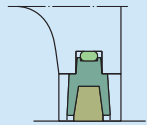
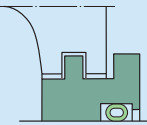
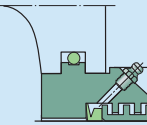
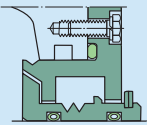
With shaft speeds continuously increasing, there was a need for a sealing solution that could accommodate higher speeds with the same high level of performance that the SKF double-lip seal could provide at lower speeds.

To meet that need, SKF developed a robust, easy-to-mount four-lip seal (→ **fig. 1**) that can accommodate peripheral speeds up to 13 m/s. This four-lip seal is made from a specially formulated thermoplastic elastomer. It is manufactured using a unique process that improves the finish of the contact surfaces so that there is less friction and heat generated by the seal. These four-lip seals, which are designed for grease lubrication, can accommodate speeds up to 13 m/s even if the housing uses a grease escape hole (suffix V). The seals are split so that they can be installed easily.

The permissible angular misalignment for shaft diameters ≤ 100 mm is approximately 1° and approximately $0,5^\circ$ for larger shafts. The seal counterface on the shaft should be ground and the surface roughness R_a should not exceed $3,2 \mu\text{m}$. The recommended shaft tolerance is h9. The axial movement of the shaft relative to the housing is not limited when four-lip seals are used. The permissible

operating temperature range for the seal is between -40 and $+100^\circ\text{C}$ (-40 to $+210^\circ\text{F}$). The seals are available from size TSN 507 L up to and including size TSN 532 L.

Each package of four-lip seals contains two seals. Consequently, when using an end cover, one seal can be kept as a spare. Four-lip seals are identified by the designation prefix TSN followed by the size identification and the suffix L, e.g. TSN 511 L.

V-ring seals

V-ring seals (→ **fig. 2**) are two-piece seals that consist of a V-ring and a galvanized, sheet steel sealing washer. A rubber lip, vulcanized to the sealing washer, fits into the seal groove in the housing. The V-ring fits tight on the shaft and seals axially against the washer. As it is turning with the shaft, the V-ring acts as a flinger. These very efficient seals are typically used in difficult applications e.g. where there are high speeds or rough finished shafts. They can accommodate peripheral speeds in excess of 7 m/s if the V-ring is prevented from moving or lifting from the shaft by a support ring. Recommended dimensions for appropriate support rings (for axial and radial location) are provided in **table 3**.

NOTE: Support rings can not be used for sizes between 205 to 211 and 306 to 314 due to limited space between the shaft and housing shaft bore.

The permissible angular misalignment for V-ring seals is approximately $1,5^\circ$ for a 50 mm shaft decreasing to approximately 1° for shaft diameters ≥ 150 mm. The axial movement of the shaft relative to the housing is limited to ± 1 mm for shaft diameters up to 65 mm, to approximately $\pm 1,2$ mm for 70–100 mm shaft diameters and to approximately $\pm 1,5$ mm for larger shaft diameters.

Each package of V-ring seals contains two seals. Consequently, when using an end cover, one seal can be kept as a spare. V-ring seals are identified by the designation prefix TSN followed by the size identification and the suffix A, e.g. TSN 511 A.

Four-lip seal

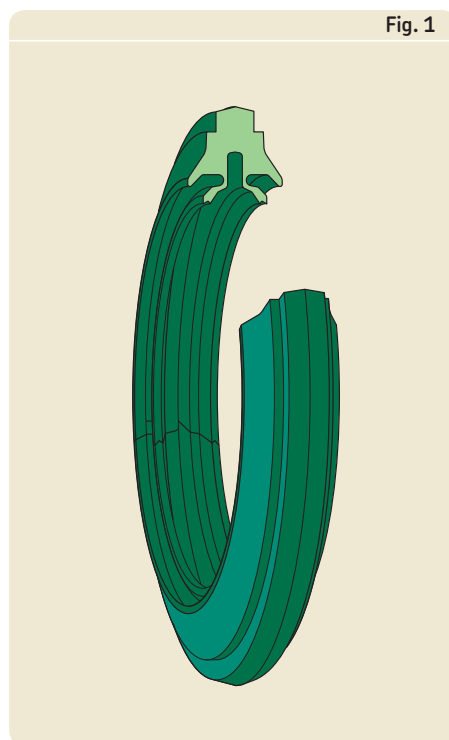

V-ring seal

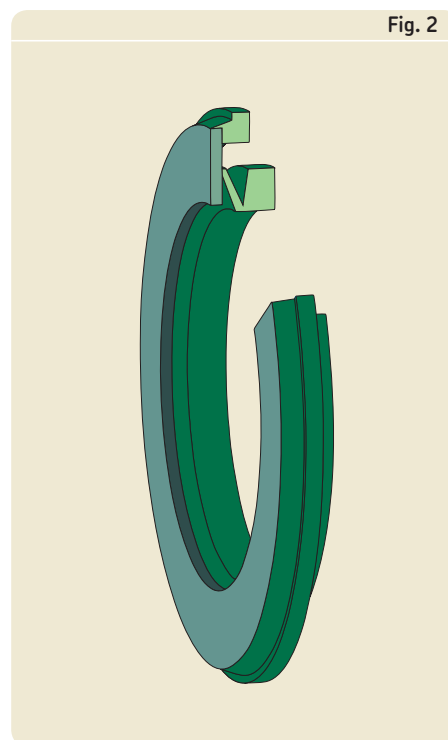
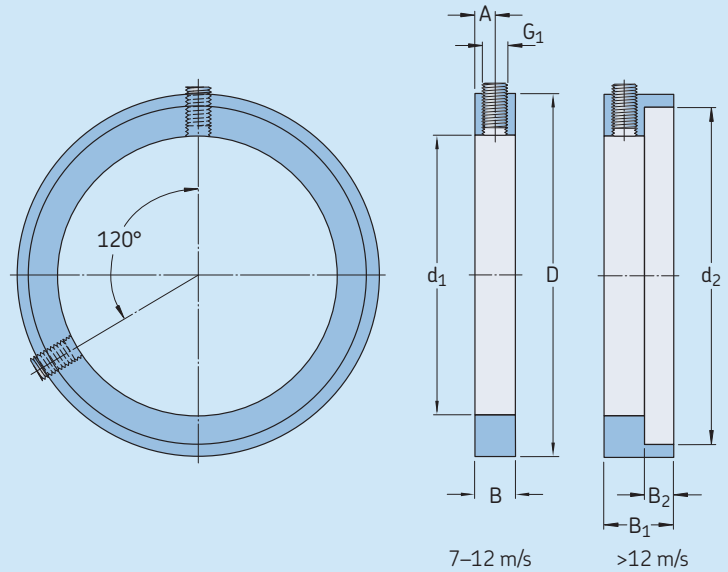

Table 3

Recommended dimensions for support rings for V-ring seals



Shaft diameter $d_a, d_b^{1)}$	Dimensions						Grub screw to DIN 913	V-ring Designation VAR	CR		
	d_1	d_2	B	B_1	B_2	D					
mm	mm						-	-	-		
20	20	27,2	5	8,5	3,5	30	2,5	M3	3 × 5	20 VAR	CR 400200
25	25	32,1	5	8,5	3,5	35	2,5	M3	3 × 5	25 VAR	CR 400250
30	30	37,2	5	8,5	3,5	40	2,5	M3	3 × 5	30 VAR	CR 400300
35	35	42,2	5	8,5	3,5	45	2,5	M3	3 × 5	35 VAR	CR 400350
40	40	49,1	7	11,5	4,5	53	3,5	M4	4 × 5	40 VAR	CR 400400
45	45	54	7	11,5	4,5	58	3,5	M4	4 × 5	45 VAR	CR 400450
50	50	59,1	7	11,5	4,5	63	3,5	M4	4 × 5	50 VAR	CR 400500
55	55	64,1	7	11,5	4,5	68	3,5	M4	4 × 5	55 VAR	CR 400550
60	60	69,1	7	11,5	4,5	73	3,5	M4	4 × 5	60 VAR	CR 400600
65	65	74,1	7	11,5	4,5	78	3,5	M4	4 × 5	65 VAR	CR 400650
70	70	81	9	15	6	84	4,5	M5	5 × 6	70 VAR	CR 400700
75	75	86	9	15	6	89,5	4,5	M5	5 × 6	75 VAR	CR 400750
80	80	91	9	15	6	94,5	4,5	M5	5 × 6	80 VAR	CR 400800
85	85	96	9	15	6	100	4,5	M5	5 × 6	85 VAR	CR 400850
90	90	101	9	15	6	105	4,5	M5	5 × 6	90 VAR	CR 400900
95	95	106	9	15	6	109	4,5	M5	5 × 6	95 VAR	CR 400950
100	100	111	9	15	6	115	4,5	M5	5 × 6	100 VAR	CR 401000
110	110	122,9	10	17,5	7,5	128	5	M6	6 × 8	110 VAR	CR 401100
115	115	127,4	10	17,5	7,5	133	5	M6	6 × 8	115 VAR	CR 401100
125	125	138,1	10	17,5	7,5	143	5	M6	6 × 8	130 VAR	CR 401300
135	135	147,5	10	17,5	7,5	153	5	M6	6 × 8	130 VAR	CR 401300
140	140	152,9	10	17,5	7,5	158	5	M6	6 × 8	140 VAR	CR 401400
145	145	158,1	10	17,5	7,5	163	5	M6	6 × 8	150 VAR	CR 401500
155	155	167,5	10	18,5	8,5	173	5	M6	6 × 8	150 VAR	CR 401500
165	165	179,9	10	18,5	8,5	185,5	5	M6	6 × 8	170 VAR	CR 401700
175	175	189,3	10	18,5	8,5	195	5	M6	6 × 8	170 VAR	CR 401700

Location of the V-ring

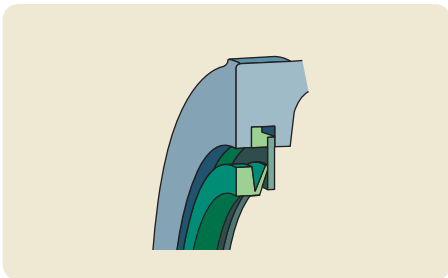

Peripheral speed up to 7 m/s

Peripheral speed 7 to 12 m/s

above 12 m/s

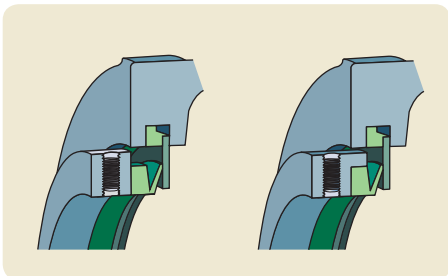

¹⁾ d_a : shaft diameter for bearings on an adapter sleeve. d_b : shaft diameter for bearings on a stepped shaft

Felt ring seals

Felt ring seals (→ **fig. 3**) are simple, efficient grease seals that can accommodate peripheral speeds up to 4 m/s. These seals can accommodate higher speeds, but beyond 4 m/s, a small gap forms between the felt and shaft, transforming the contact seal into a non-contact, gap-type seal.

In applications where bearings are mounted on a straight shaft with adapter sleeve, split felt ring seals are typically used (→ **fig. 3a**). The felt is impregnated with oil. To install these seals, a round rubber cord is first inserted into the seal groove in the housing. Then, with the felt inserted in the light alloy half-rings, the half rings are installed in the seal groove. The rubber cord prevents the rings from turning.

The permissible angular misalignment for felt ring seals is approximately $0,5^\circ$. The seal counterface on the shaft should be ground and the surface roughness R_a should not exceed $3,2 \mu\text{m}$.

The axial movement of the shaft relative to the housing is not limited when felt seals are used.

Each package of felt ring seals contains two seals. Consequently, when using an end cover, one seal can be kept as a spare. Felt ring seals

are identified by the designation prefix TSN followed by the size identification and the suffix C, e.g. TSN 511 C.

High temperature applications

For applications where spherical roller bearings or CARB toroidal roller bearings operate continuously at high temperatures, up to $+250^\circ\text{C}$ (480°F), SKF graphited FSB seals should be used. These seals are made of aluminium boron silicate and can accommodate speeds up to 2 m/s.

Felt ring seals can be supplied with an FSB insert. The round rubber cords used with these seals are replaced with a fluoro rubber cord. These seals are identified by the suffix CB, e.g. TSN 511 CB.

Felt strips

If the bearings are to be installed on a stepped shaft with a cylindrical seat (sizes 205 to 218 inclusive), loose felt strips (→ **fig. 3b**) can be used. The strips are 170 mm in length. They should be cut to the right length and prior to installation, they must be soaked in hot oil for a few minutes. Then, they can be installed directly into the seal groove. The felt strips are designated FS 170.

Seals made of fluoro rubber give off hazardous fumes when exposed to extreme temperatures above 300°C (570°F).

Therefore, review and follow the safety recommendations mentioned in the section "Seal materials" in the General Catalogue 6000, on **page 143**.

High temperature applications

For high operating temperatures, up to $+250^\circ\text{C}$ (480°F), SKF graphited strips can be supplied. They should be cut to the right length. They can be installed directly into the seal groove.

Contact SKF for correct designation.

Felt ring seal

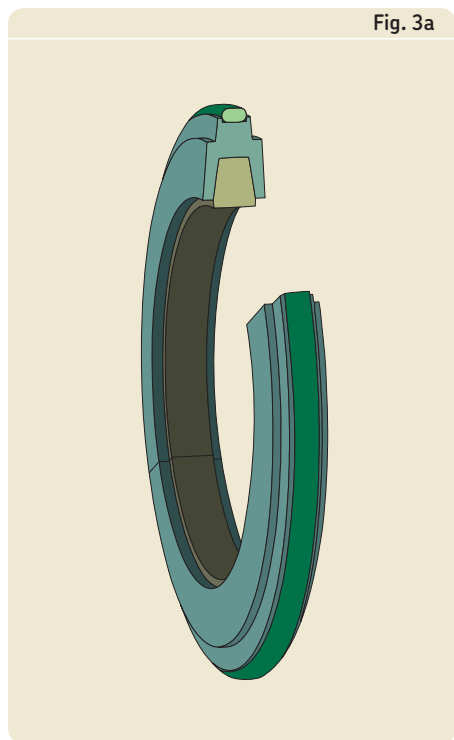

Fig. 3a

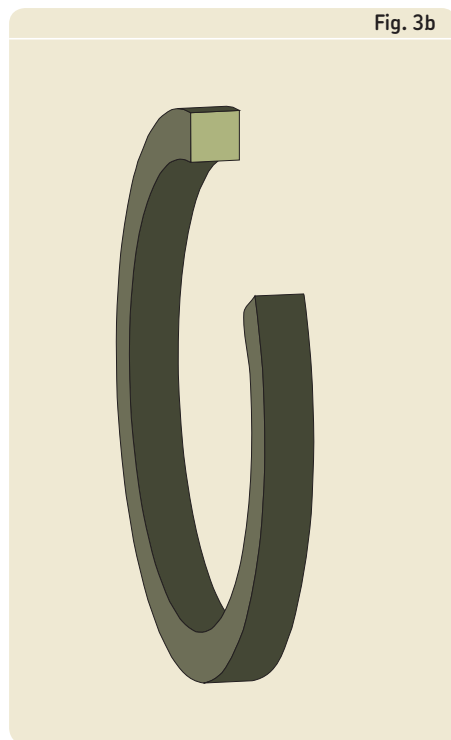
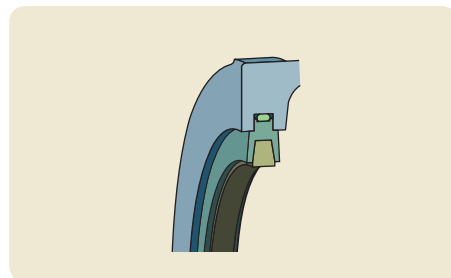
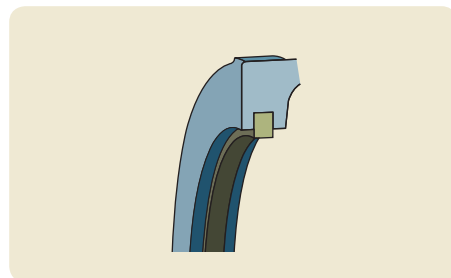

Fig. 3b



Felt ring seal

Felt strips



Labyrinth seals

For applications where there are high speeds and/or extreme temperatures, SKF recommends using a labyrinth type seal (→ **fig. 4**). The standard labyrinth type seal is called a labyrinth ring. Labyrinth rings consist of a metal ring with two steps arranged radially. One step fits in the seal groove in the housing to form a gap type seal. The other step forms a gap type seal with the outside of the housing. A hollow, silicone rubber cord supplied with the seal holds the labyrinth ring in place on the shaft.

The standard labyrinth seals can accommodate approximately $0,3^\circ$ of angular misalignment and operating temperatures ranging from -50 to $+200$ °C (-60 to $+390$ °F).

When labyrinth seals are used, axial movement of the shaft relative to the housing is not limited. The recommended shaft tolerance is h9.

Labyrinth rings are supplied singly. For through-shaft applications, two rings should be ordered. A labyrinth ring is identified by the designation prefix TSN followed by the size identification and the suffix S, e.g. TSN 511 S.

Taconite heavy-duty seals

Taconite is a very fine-grained mineral which is extremely difficult to seal against. For bearing arrangements which must operate under very arduous conditions such as those encountered in mining, labyrinth seals, which can be relubricated, are recommended, as grease enhances the sealing effect and extends the serviceability of the seals. SKF has developed different designs of these heavy-duty seals (which can seal against taconite, hence the name) that can be supplied for use with SNL housings.

One taconite seal design (→ **fig. 5**) is based on a radial labyrinth seal and fits standard housings. A V-ring seal mounted on the shaft seals against the non-rotating part of the seal, which is inserted in the seal groove and prevents contaminants from penetrating to the bearing when the seal is relubricated. This grease is supplied via a grease fitting in the non-rotating part of the seal. Angular misalignments of the shaft of up to approximately $0,5^\circ$ are possible. The permissible operating temperature range for the seal is between -40 and $+100$ °C (-40 to $+210$ °F).

The axial movement of the shaft relative to the housing is limited for this type of taconite seal to ± 1 mm for shaft diameters up to 65 mm and to approximately $\pm 1,2$ mm for sizes up to 100 mm and $\pm 1,5$ mm for larger shaft diameters. The recommended shaft tolerance is h9.

These seals are supplied singly so that for housings used on through shafts, it is necessary to order two seals. The seal is identified by the designation prefix TSN followed by the size identification and the suffix ND, e.g. TSN 511 ND.

The second design of taconite seal (→ **fig. 6**) is based on a labyrinth seal with the labyrinth stages arranged axially. The seal is relubricated via lubrication holes and fittings in the housing cap. The positions for the holes are marked by dimples in the casting. The permissible misalignment of the shaft relative to the housing for this seal is approximately $0,5^\circ$. The operating temperature range is from -40 to $+250$ °C (-40 to 480 °F). Axial movement of the shaft relative to the housing is also limited. The recommended shaft tolerance is h9.

Labyrinth seal

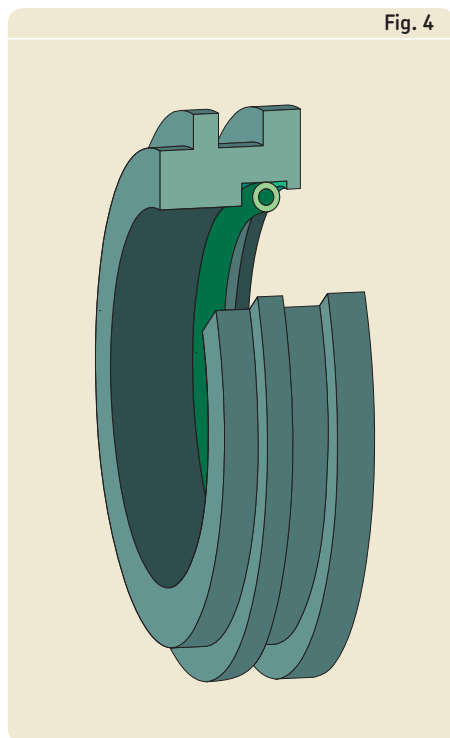

Taconite heavy-duty seal with a radial labyrinth

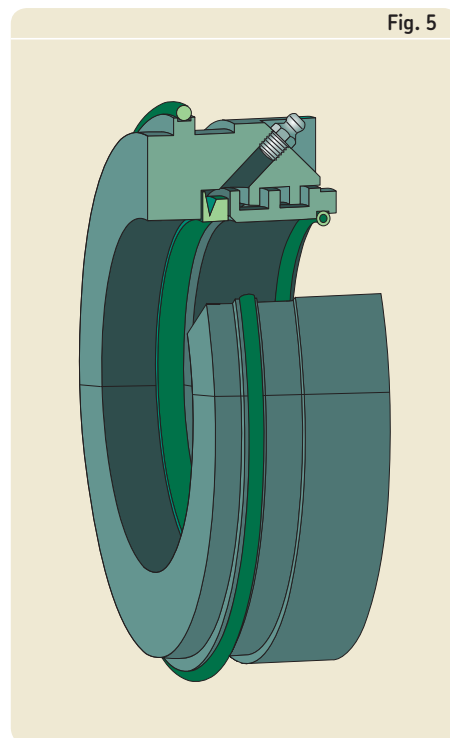

Taconite heavy-duty seal with an axial labyrinth

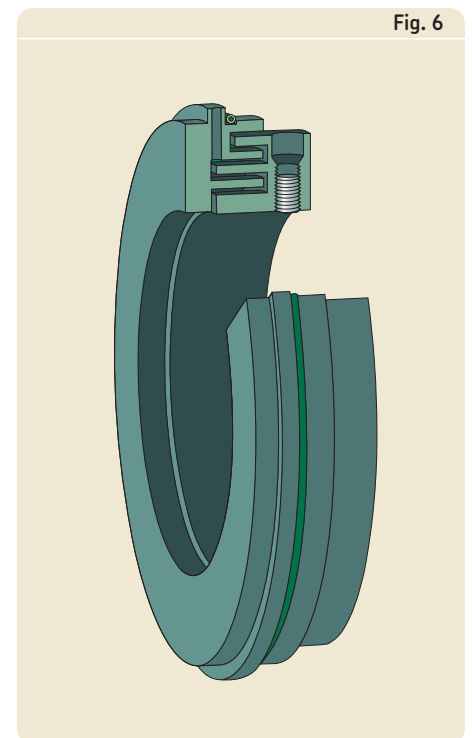

These seals require that a variant of the standard housing is ordered, either suffix T for housing used with end cover when lubrication on only one side of housing is required or suffix TD for through shaft when lubrication possibilities is required on both sides of the housing. The seals are available from size 515-612. The seals are supplied separately and is identified by the designation prefix TSN followed by the size identification and the suffix NC, e.g. TSN 515-612 NC.

The third variant of the Taconite seal has the same design as the Taconite heavy-duty seal with an axial labyrinth but includes an V-ring seal (→ fig. 7) and requires the same modified housing prepared for lubrication on one or two sides of the housing, e.g. suffix T or TD, as the second seal variant. The seal is available from size 515-612. The seals are supplied separately and is identified by the designation prefix TSN followed by the size identification and the suffix NB, e.g. TSN 515-612 NB.

Seals for oil lubrication

To retain oil in an SNL housing and prevent leaks, SKF has developed a U-design labyrinth seal (→ fig. 8). These seals, which require a modified housing, consist of two parts: a stationary U-shaped plate that is bolted to the housing, and a steel labyrinth ring that is mounted on the shaft. Two hollow, silicone rubber cords inserted between the loose fitting labyrinth ring and shaft, keep the ring in place and prevent oil from escaping along the shaft. To keep the two seal parts together, a retaining ring is mounted on the labyrinth ring. These oil seals do not limit axial movement of the shaft relative to the housing. The recommended shaft tolerance for these seals is g7, but h9 is acceptable.

Modified SNL housings for oil lubrication are supplied together with seals. The housings with seals are identified by designation suffix TURU, e.g. SNL 524 TURU. Special end covers, designation ASNH .. R, must be ordered separately.

SNL .. TURU housings are prone to overfilling with oil. This is due to the limited size of the SNL sump. For this reason, it is very important not to exceed the recommended oil level if leaks are to be avoided (→ table 3 on page 30).

SONL housings for oil lubrication

As part of the SNL assortment, SKF has a full line of SONL housings, specifically designed for oil lubrication. Available for shaft diameters ranging from 75 to 240 mm, these housings are not as prone to overfilling as SNL housings. Other advantages of the SONL housing include

- a 15 % larger oil sump (reservoir)
- cooling fins inside the casting for improved heat dissipation.

For additional information about SONL plummer block housings, → SKF publication 6111 "SONL plummer housings – designed for oil lubrication."

Taconite heavy-duty seal with an axial labyrinth and an V-ring seal

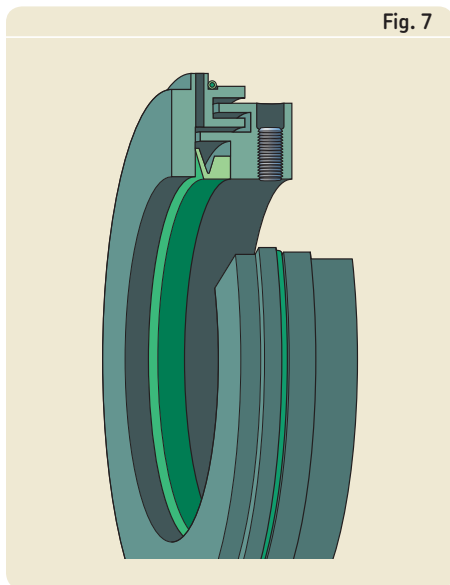

Oil seal

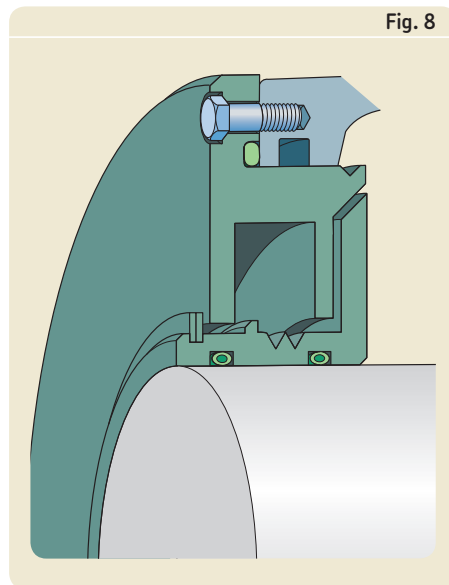

Special seals

For applications that require special seals, SKF recommends ordering housings in the SNL 2 series rather than those in the 5 or 6 series. Housings in the SNL 2 series have a larger bore (D_b) and can accommodate a wider choice of seal designs.

Special seals are not normally supplied by SKF. Therefore, relevant seal groove dimensions are provided in **table 4**.

Table 4

Seal groove dimensions

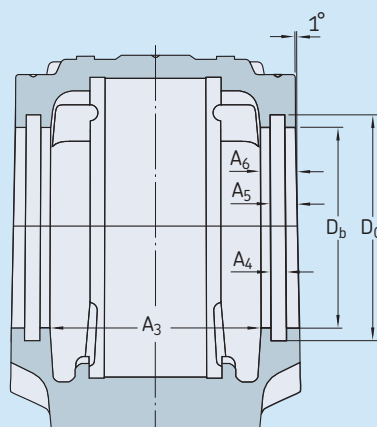

Housing Size	Dimensions					
	A_3	A_4	A_5	A_6	D_b	D_c
–	mm					
SNL 205	44	5	7,5	10	36,5	44,5
SNL 206-305	54	5	7,5	10	46,5	54,5
SNL 207	58	5	8	11	56,5	64,5
SNL 208-307	61	5	8	11	62	70,5
SNL 209	59	5	9	12	67	75,5
SNL 210	64	5	9	12	72	80,5
SNL 211	69	5	9	12	77	85,5
SNL 212	79	5	9	12	87	95,5
SNL 213	82	5	9	13	92,5	101
SNL 215	87	5	9	13	102,5	111
SNL 216	92	5	9	13	108	116,5
SNL 217	97	5	9	13	112	120,5
SNL 218	112	5	9	13	120	128,5
SNL 505	45	5	7,5	10	31,5	39,5
SNL 506-605	55	5	7,5	10	36,5	44,5
SNL 507-606	59	5	8	11	46,5	54,5
SNL 508-607	62	5	8	11	51,5	59,5
SNL 509	60	5	9	12	56,5	64,5
SNL 510-608	65	5	9	12	62	70,5
SNL 511-609	70	5	9	12	67	75,5
SNL 512-610	80	5	9	12	72	80,5
SNL 513-611	83	5	9	13	77	85,5
SNL 515-612	88	5	9	13	87	95,5
SNL 516-613	93	5	9	13	92,5	101
SNL 517	98	5	9	13	97,5	106
SNL 518-615	113	5	9	13	102,5	111
SNL 519-616	116	6	10	14	131	141
SNL 520-617	131	6	10	14	137,5	147,5
SNL 522-619	143	6	10	14	147,5	157,5
SNL 524-620	151	6	11	15	157,5	167,5
SNL 526	156	6	11	15	167,5	177,5
SNL 528	171	6	11	15	177,5	187,5
SNL 530	189	6	11	15	192,5	202,5
SNL 532	201	6	11	15	202,5	212,5

End covers

Housings mounted at the end of a shaft should be fitted with an end cover that fits into the seal groove (→ **fig. 9**). Details of the permissible length of the shaft end can be found in **table 5**. End covers, which are plastic, are suitable for operating temperatures ranging from -40 to $+110$ °C (-40 to $+230$ °F).

For applications where temperatures exceed 110 °C (230 °F), steel end covers should be used. These can be cut from sheet steel and placed in the seal groove. Use a hollow silicone rubber cord to hold the cover in place. Seal groove dimensions are provided in **table 4** on **page 21**.

The standard plastic end cover is identified by the designation prefix ASNH followed by the housing size identification, e.g. ASNH 511-609.

Locating rings

The width of the bearing seat in SNL housings is machined in such way that it can accommodate bearings in the locating as well as in the non-locating position.

The locating bearing, which locates the shaft axially in both directions, must be secured in the housing on both sides with a locating ring (→ **fig. 10**).

In most cases, the non-locating bearing is free to move axially in the housing to accommodate thermal expansion of the shaft. However, CARB toroidal roller bearings are an exception. These bearings accommodate axial displacement internally and must therefore be secured in the housing, on both sides, with a locating ring.

Locating rings are identified by the designation prefix FRB followed by figures indicating the width/outside diameter in millimetres, e.g. FRB 11.5/100.

Housing with an end cover

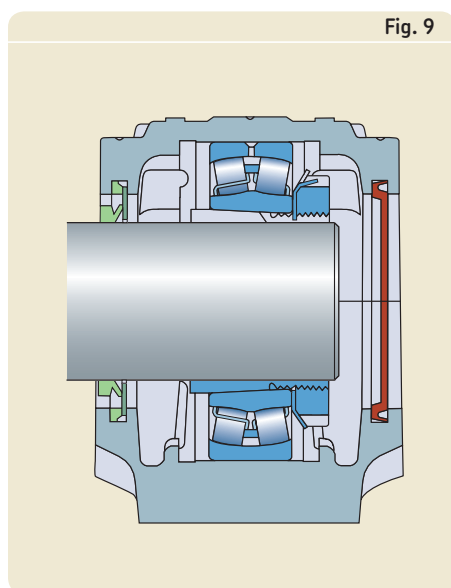

Housing with a locating ring at both sides of the bearing

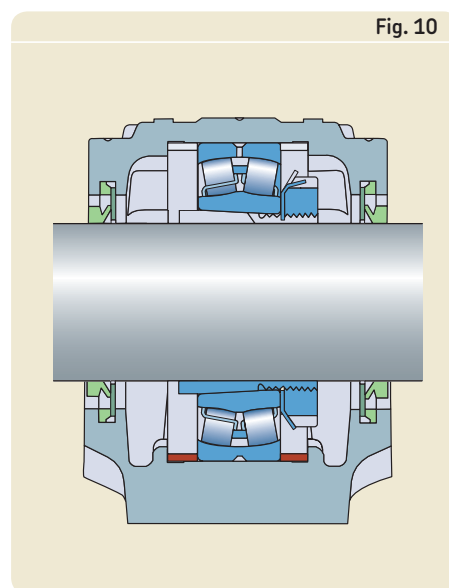

Permissible length of shaft end

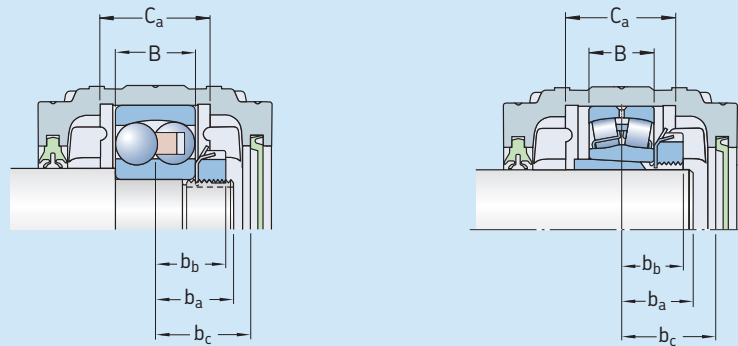

Housing Size	Dimensions			Widest bearing that fits the housing Designation	Dimensions	
	$b_a^{1)}$	b_c	C_a		B	b_b
–	mm			–	mm	
SNL 205	18	24	25	22205 E	18	17
SNL 206-305	20	29	32	2305 E	24	19
SNL 207	23	32	34	22207 E	23	20,5
SNL 208-307	26 (22)	33	39	2307 E	31	24,5
SNL 209	25	32	30	22209 E	23	22,5
SNL 210	28 (24)	35	41	22210 E	23	23,5
SNL 211	30 (25)	37	44	22211 E	25	25
SNL 212	33 (26)	42	48	22212 E	28	27
SNL 213	35 (30)	45	51	22213 E	31	29,5
SNL 215	37 (30)	47	56	22215 E	31	30,5
SNL 216	39 (33)	50	58	22216 E	33	33,5
SNL 217	40 (35)	52	61	22217 E	36	36
SNL 218	45 (35)	60	65	23218 CC/W33	52,4	44,2
SNL 505	18	24	25	22205 EK	18	17
SNL 506-605	20	29	32	2305 EK	24	19
SNL 507-606	23	32	34	2306 EK	27	21,5
SNL 508-607	26 (22)	33	39	2307 EK	31	24,5
SNL 509	25	32	30	22209 EK	23	22,5
SNL 510-608	28 (24)	35	41	22308 EK	33	26,5
SNL 511-609	30 (25)	37	44	22309 EK	36	29
SNL 512-610	33 (26)	42	48	22310 EK	40	32
SNL 513-611	35 (30)	45	51	22311 EK	43	33,5
SNL 515-612	37 (30)	47	56	22312 EK	46	36
SNL 516-613	39 (33)	50	58	22313 EK	48	38
SNL 517	40 (35)	52	61	22217 EK	36	36
SNL 518-615	45 (35)	60	65	22315 EK	55	42,5
SNL 519-616	47 (40)	61	68	22316 EK	58	46
SNL 520-617	51 (45)	69	70	23220 CCK/W33	60,3	50,2
SNL 522-619	61	75	80	23222 CCK/W33	69,8	55,9
SNL 524-620	65	79	86	23224 CCK/W33	76	60
SNL 526	65	81	90	23226 CCK/W33	80	63
SNL 528	70	89	98	23228 CCK/W33	88	68
SNL 530	80	98	106	23230 CCK/W33	96	74
SNL 532	85	104	114	23232 CCK/W33	104	80

¹⁾ The dimension b_a suits all appropriate bearings, with two exceptions:

1. For self-aligning ball bearings in the 12 series, values between brackets are suitable for total bearing inner ring seat
2. For non-locating bearing arrangements, in particular for bearings with the widest possible width (see table), the values for b_a must be correspondingly adjusted (reduced or increased) when the bearing is not mounted centrally (→ page 24)

Axial displacement using CARB toroidal roller bearings in SNL housings

with a KML nut indicated by suffix L in the sleeve designation, e.g. H 2324 L.

Axial displacement reduces clearance in a CARB bearing. As a result, the permissible axial displacement depends on the clearance in the bearing after mounting. Insufficient radial clearance, combined with axial displacement, could actually result in a preload condition that causes the bearing to fail prematurely. See general catalogue for calculation of permissible axial displacement.

Even if clearance is sufficient, axial displacement in a CARB bearing is limited by the distance the inner ring can move by any one of the following

- rollers start to be exposed on one side of the bearing
- lock nut/locking washer fouls the rollers and cage
- type of seal.

To avoid the rollers and cage assembly from contacting the lock nut/ washer, bearings in the C 22 K series, up to and including size 22, should be used with a special adapter sleeve that has a narrow slot and a self-locking KMFE nut. These sleeves are identified by the suffix E, e.g. H 311 E (→ **fig. 11**).

For bearings in the C 22 K and C 32 K series from size 24 and above, sleeves are supplied

CARB toroidal roller bearing on a stepped shaft and an adapter sleeve incorporating a self-locking KMFE nut

Fig. 11

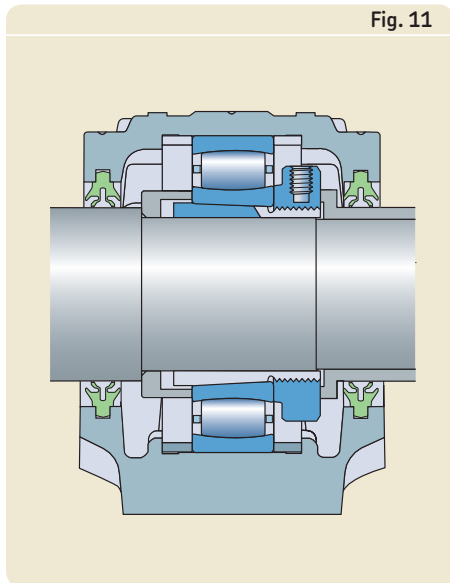

Application advice for trouble-free operation

Condition monitoring is recommended for SNL plummer blocks, particularly if they are fitted to machines where bearing failures would cause production stoppages. The early recognition and trending of the degradation of the machine and machine parts make it possible to analyse the root cause and to be able to plan for corrective maintenance actions before they are needed.

Extensive monitoring experience and a knowledge of the dynamic behaviour of machines, machine components and bearings where there is incipient damage enables SKF to recommend two powerful signal processing techniques that can be used for condition monitoring.

Vibration velocity

The RMS (root mean square) of the velocity of vibrations in the frequency range 10 Hz to 1 kHz has been used with great success to measure phenomena such as imbalance, misalignment, resonance etc. High levels of velocity vibration can be generated by poor machine conditions such as improper clearances, imbalance, misalignment, weak foundations, bent rotors, out-of-round, belt problems or damaged fan blades. The ISO Standard 10816-1:1995 contains recommendations for reference values for the RMS velocity values measured on different classes of machines and machine parts. These recommendations provide a clear and quantifiable measure for the changes in machine condition. Vibration velocity expressed as an overall RMS value in the 10 Hz to 1 kHz frequency range provides minimal information on defects in rolling element bearings or gear mesh problems. These types of defect can now be easily detected by enveloped acceleration in the higher frequency ranges.



SKF Multilog online system IMx-T



SKF Machine Condition Transmitters (MCT)



SKF Microlog series data collectors/analysers

Enveloped acceleration

Bearing defects can be easily recognized by measurement and analysis of an enveloped acceleration signal of the higher frequencies generated by the impact signals typical of rolling bearing defects and gear teeth problems. This technique has proven to be extremely reliable in the detection of incipient bearing defects. The low frequencies generated by imbalance, misalignment etc. are not measured and diagnosed within the enveloped acceleration process.

- Condition monitoring and diagnosis with permanently installed monitoring systems

The SKF Multilog online system IMx-T is the next generation of powerful, cost-effective solutions for a variety of condition monitoring applications. Together with SKF @ptitude Observer software, Multilog IMx-T provides a complete for early fault detection and prevention, automatic advice for correcting existing or impending conditions and advanced condition based maintenance to improve machine reliability, availability and performance.

SKF's Machine Condition Transmitters (MCT) deliver added value to essential production equipment by providing vital information on bearing performance that helps maximize potential machine utilization. Highly cost-effective, using MCTs mean potential problems can be spotted before they deteriorate, so maintenance and repair schedules can be forecast and production arrangements can continue as planned.

Each stand-alone monitoring device may be permanently mounted onto a machine, providing low-cost continuous monitoring of specific machine, gear and bearing performance parameters in pumps, fans, motors and other general-purpose machinery.

- Condition monitoring and diagnosis with a portable data collector and analyser

SKF offers a range of portable condition monitoring hardware, designed to assess and report on temperature, oil condition, speed, bearing condition, shaft alignment, noise, vibration and more. Where a measurement point is difficult to access, permanently installed sensors can be used. These can be connected by cable to a connection box accessible to the data collector.

SNL housings prepared for condition monitoring

SNL housings have appropriate points for sensors (→ **fig. 1**). Measuring point in position 1 is perpendicular to the shaft, while position 2 is parallel to the shaft. Both points correspond to ISO 10816-1:1995. The measurement point in position 3 is at approximately 45° to the shaft axis. For enveloped acceleration, the angle of inclination of the measuring point is of minor importance.

Measurement point in position 2 should be used on SNL housings where the load acts toward the base plate. The measuring point in position 1 is intended for a housing that is hung from its support or when the load acts away from the base plate.

Housings with a tapped hole for a sensor in position 3 can be supplied on request. These housings are designated with the suffix SN.

For additional information about condition monitoring and the measurement tools and systems available from SKF, contact the SKF application engineering service.

Measuring points for condition monitoring

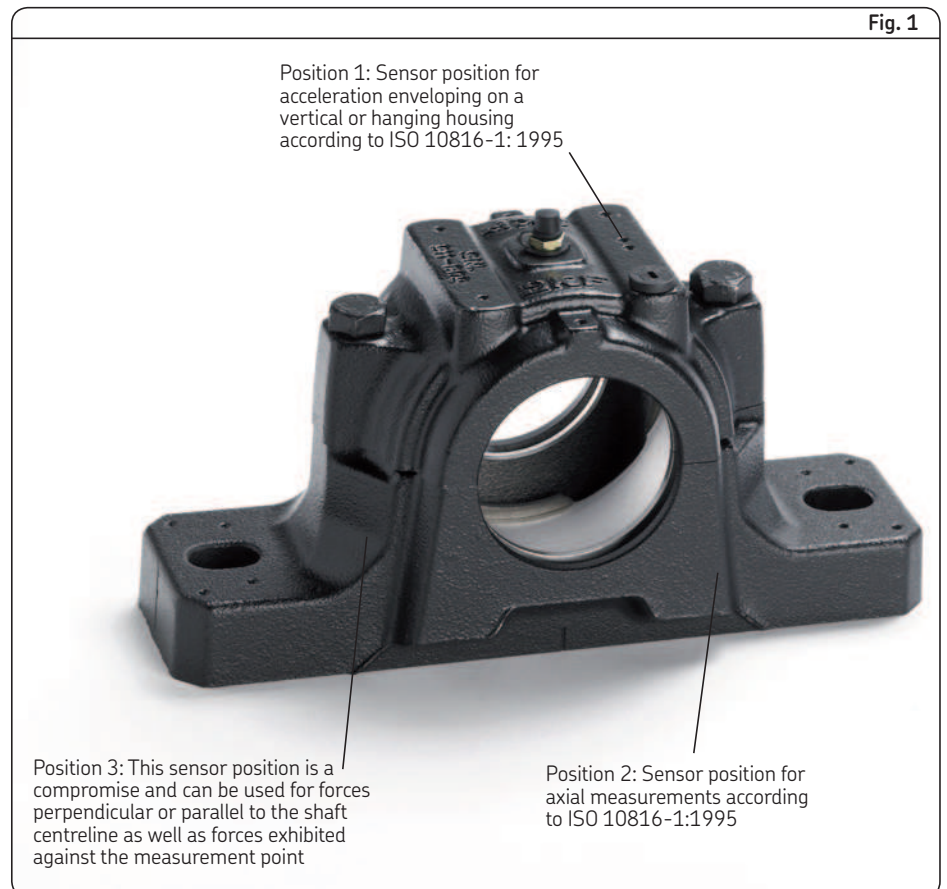

Lubrication

SNL plummer blocks can accommodate either grease or oil as a lubricant, but grease is preferred. For oil, SKF recommends SONL housings. Whichever housing is used, the lubricant should be selected based on the operating conditions. Additional information about lubricant selection can be found in the SKF General Catalogue.

Grease lubrication

In most applications, the initial grease fill in an SNL housing will adequately lubricate the bearing until the next planned inspection. However, certain operating conditions such as high speeds, high temperatures or heavy loads may require more frequent relubrication. **Table 1** provides guideline values for the initial grease fill. Depending on the intended method of relubrication, the following grease fill percentages for the free space in the housing are recommended

- 40 % when relubricating from the side of the bearing
- 20 % when relubricating through the annular groove and lubrication holes in the bearing outer ring.

In either case, the free space in the bearing should be completely filled with grease. For relubrication quantities, more information can be found in the SKF General Catalogue. Six dimples cast into the top of the housing cap indicates where holes can be drilled and tapped to accommodate a grease fitting. One dimple on each outer side of the central ridge indicates a hole location to relubricate the seal. SNL housings have, as standard, two holes that have been drilled and tapped for a grease fitting AH 1/8-27 PTF (→ **fig. 2**). On a new housing, the holes are covered by plastic plugs. These plugs should be replaced with the grease fitting and threaded plug supplied with the housing. The hole in the middle of the cap should be used to relubricate spherical roller bearings with a lubrication groove and three holes in the outer ring, designation suffix E or W33 (→ **fig. 3**). For SNL housings from size 524 having an eye-bolt in centre of housing this hole is drilled in one of the bosses (→ **fig. 4**). It should be noted that when spherical roller bearings are to be lubricated via the outer ring, the shaft should be rotating. If outer ring relubrication is not possible, or if self-aligning ball bearings or CARB toroidal roller bearings are used, the other stand-

Table 1

Grease quantities					
Housing Size	Grease quantities		Housing Size	Grease quantities	
	First fill 40 %	First fill 20 %		First fill 40 %	First fill 20 %
–	g	g	–	g	g
SNL 205	25	15	SNL 505	25	15
SNL 206-305	40	25	SNL 506-605	40	25
SNL 207	50	30	SNL 507-606	50	30
SNL 208-307	60	35	SNL 508-607	60	35
SNL 209	65	40	SNL 509	65	40
SNL 210	75	45	SNL 510-608	75	45
SNL 211	100	60	SNL 511-609	100	60
SNL 212	150	90	SNL 512-610	150	90
SNL 213	180	110	SNL 513-611	180	110
SNL 215	230	140	SNL 515-612	230	140
SNL 216	280	170	SNL 516-613	280	170
SNL 217	330	200	SNL 517	330	200
SNL 218	430	260	SNL 518-615	430	260
			SNL 519-616	480	300
			SNL 520-617	630	390
			SNL 522-619	850	530
			SNL 524-620	1 000	630
			SNL 526	1 100	700
			SNL 528	1 400	900
			SNL 530	1 700	1 100
			SNL 532	2 000	1 300

Grease fitting AH 1/8-27 PTF



Relubricating a bearing via the outer ring and grease escape hole

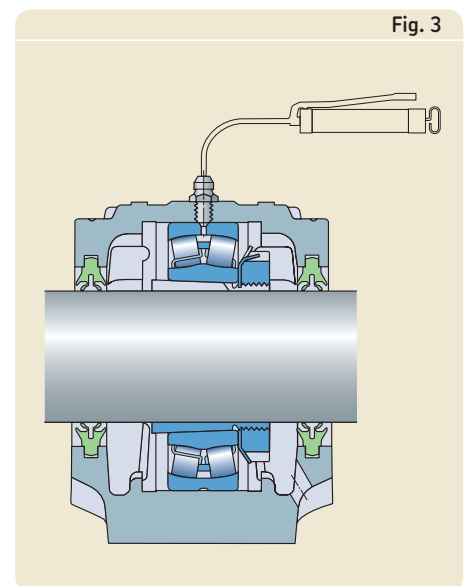

ard hole should contain the grease fitting (→ **fig. 5**) and the centre hole should be plugged. If a different size grease fitting will be used, adapters that fit into the existing holes are available (→ **fig. 6**), making rework unnecessary.

To improve the effectiveness of relubrication in applications where V-rings are used, mount an additional V-ring inside the housing on the side where grease is applied. Doing this forces grease to travel through the bearing to reach the escape hole on the opposite side of the housing. For this type of sealing arrangement, SKF supplies a V-ring and a splash plate that fits in the seal groove to cover a bit more than the top half of the housing (→ **fig. 7**). The V-ring and splash plate set is identified by the designation prefix ASNA followed by the housing size identification and the suffix V, e.g. ASNA 511 V.

In applications where bearings are mounted on adapter sleeves, the grease should be introduced from the opposite side of the lock nut. If the housing is located at the end of a shaft, grease should be applied at the point closest to the end cover.

In applications where L or C design seals are used, grease cannot escape via the seals. Therefore, if frequent relubrication is required, SKF recommends using a grease escape hole (→ **fig. 3 and 5**). SNL housings with a grease escape hole are identified by the suffix V, e.g. SNL 511-609 V. Recommended dimensions can be found in **table 2** on **page 30**.

Bearing relubrication at the side of the housing, via a standard grease fitting and grease escape hole

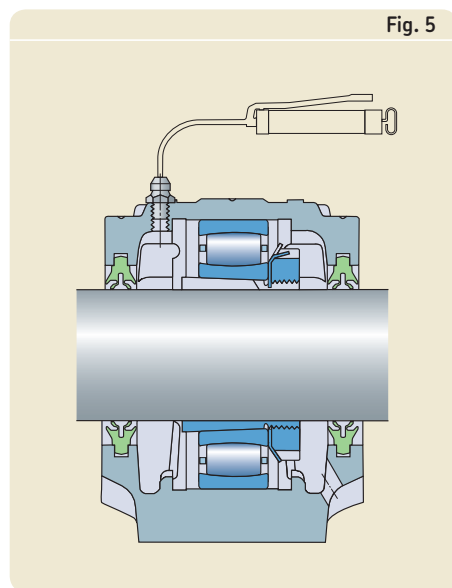

Adapter

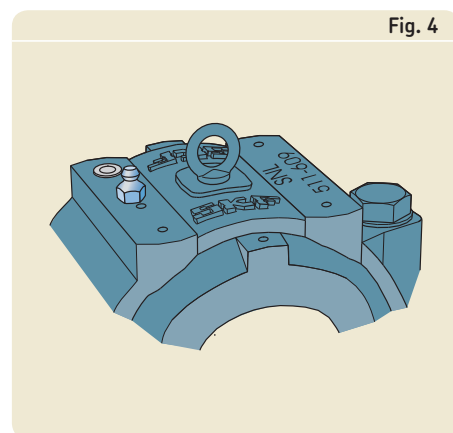

SNL housing having an eye-bolt in centre of housing

Housing with an additional V-ring and splash plate

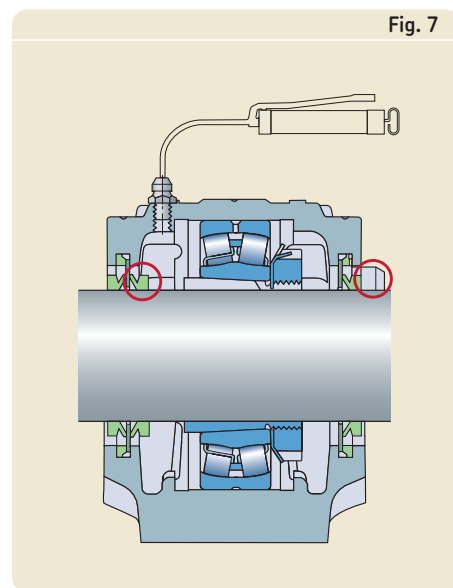
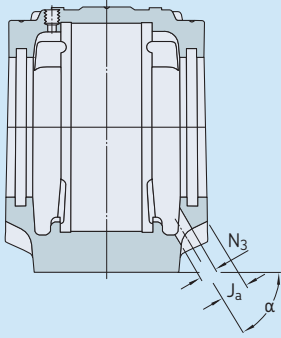

Table 2

Recommended dimensions for grease escape holes



Housing Size	Dimensions		
	J_a	N_3	α
–	mm		degrees
SNL 205	8,5	10	45
SNL 206-305	10	10	45
SNL 207	10	10	45
SNL 208-307	9	10	45
SNL 209	10	10	45
SNL 210	11	10	45
SNL 211	10	12	45
SNL 212	9	12	45
SNL 213	13	12	45
SNL 215	12,5	12	45
SNL 216	14	16	45
SNL 217	17	16	45
SNL 218	20	16	40
SNL 505	8,5	10	45
SNL 506-605	10	10	45
SNL 507-606	10	10	45
SNL 508-607	9	10	45
SNL 509	10	10	45
SNL 510-608	11	10	45
SNL 511-609	10	12	45
SNL 512-610	9	12	45
SNL 513-611	13	12	45
SNL 515-612	12,5	12	45
SNL 516-613	14	16	45
SNL 517	17	16	45
SNL 518-615	20	16	40
SNL 519-616	20	16	50
SNL 520-617	21	16	50
SNL 522-619	21	20	50
SNL 524-620	24	20	55
SNL 526	22	20	55
SNL 528	23	20	50
SNL 530	25	20	55
SNL 532	25	20	60

The dimensions are those recommended when the standard AH 1/8-27 PTF grease fitting is used (supplied with the housing) but can also be applied if fittings with R 1/8, KR 1/8 or M 10x1 threads are used. An adapter is available that fits the SNL standard lubrication hole, designation LAPN 1/8. Using this adapter fitting with G 1/4 thread and grease dispensers, e.g. SKF SYSTEM 24, can be applied.

Table 3

Recommended oil levels for SNL .. TURU plummer block housings in the 5 series

Housing Designation	Oil level for bearings in the series									
	12		22		232		222		C 22	
–	min	max	min	max	min	max	min	max	min	max
–	mm									
SNL 511 TURU	27	31	27	32	–	–	27	31	28	32
SNL 512 TURU	23	27	22	28	–	–	23	27	23	26
SNL 513 TURU	29	33	28	34	–	–	28	33	29	34
SNL 515 TURU	24	29	23	29	–	–	23	28	24	29
SNL 516 TURU	34	39	33	40	–	–	33	39	34	39
SNL 517 TURU	30	36	30	36	–	–	29	35	30	36
SNL 518 TURU	31	38	31	38	33	37	30	37	30	36
SNL 519 TURU	38	45	38	46	–	–	38	45	39	46
SNL 520 TURU	34	42	34	42	37	42	33	41	35	43
SNL 522 TURU	39	47	38	48	42	47	37	46	39	48
SNL 524 TURU	47	57	–	–	50	55	46	55	46	56
SNL 526 TURU	–	–	–	–	54	59	50	59	52	62
SNL 528 TURU	–	–	–	–	46	52	44	52	40	51
SNL 530 TURU	–	–	–	–	48	54	45	54	44	57
SNL 532 TURU	–	–	–	–	50	57	47	57	–	–

The oil level is measured from the base of the housing. Mark the min and max level on the sight glass. For housings in the 3 and 6 series, consult SKF

Grease guiding system

SKF has developed a grease guiding system for SNL housings (→ **fig. 8**). The housing contains an integrated flange that guides lubricant from the grease fitting directly to the rolling elements to provide a more efficient means of relubrication. This design feature is available on housings from size 511 up to and including size 532.

Oil lubrication

SNL housings can be used for oil lubrication at relatively high speeds provided the housing has been modified. When using oil, it is important to not overfill the sump and to use specially developed U design seals (→ **fig. 9**) or leaks may result. These seals, which are described on **page 20**, are supplied with the housing.

In order for these seals to be used, the housing must be modified. SNL housings for oil lubrication are supplied from SKF complete with seals, ventilation plug and oil sight glass. It is important not to exceed the recommended oil level if leakage is to be avoided (→ **table 3**).

Grease guiding system

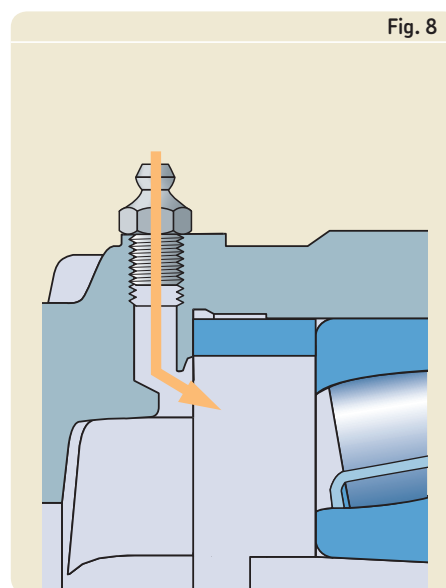

Housing for oil lubrication

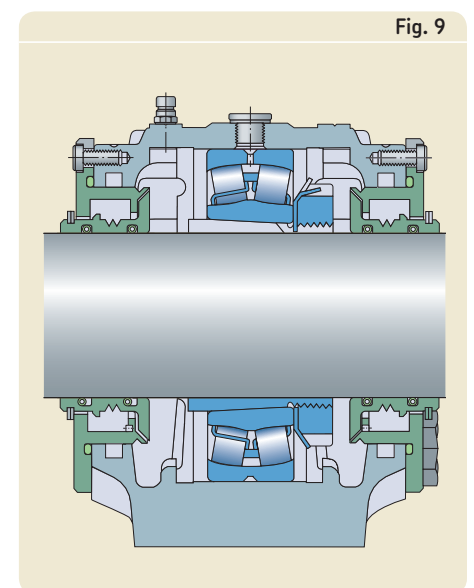

Mounting

SNL housings, together with the appropriate SKF bearings, can create a robust, operationally reliable system that will provide long service life. However, if the system is to achieve maximum service life, each component must be mounted properly, using the correct tools.

Bearings can be mounted either on a tapered seat – typically an adapter sleeve – or on a cylindrical seat.

Mounting bearings on a tapered seat

When a bearing is mounted correctly on a sleeve, there will be an interference fit between the inner ring, sleeve and shaft. The degree of interference depends on how far the bearing is driven up the sleeve and can be determined either by measuring the reduction of internal clearance in the bearing with a feeler gauge or by measuring the drive-up distance.

Clearance reduction in a self-aligning ball bearing with Normal radial internal clearance, can be checked by turning and swiveling the outer ring. If, when swiveling, the outer ring provides slight resistance, it has a sufficient degree of interference and the drive-up is complete.

Another simple way to mount a self-aligning ball bearing on an adapter sleeve is to use a TMHN 7 lock nut spanner (available for bore sizes up to 55 mm). These specially designed spanners are marked with the angle through which the lock nut should be turned.

Small spherical roller and CARB toroidal roller bearings can also be mounted on an adapter sleeve with a TMHN 7 spanner. However, when mounting either of these bearings, do not to use the angle on the spanner, as it is meant only for self-aligning ball bearings. Appropriate angles can be found in the tables in the chapters concerning spherical roller bearings and CARB toroidal roller bearings in the SKF General Catalogue.

To install larger spherical roller or CARB toroidal roller bearings, either the clearance reduction or the SKF Drive-up Method should be used. When using a feeler gauge to measure clearance reduction, it is important that the inner and outer rings of the bearing are not displaced relative to each other.

Details of the spanner lock nut set TMHN 7, several other mounting tools as well as the SKF Drive-up Method can be found in the catalogue MP3000 “SKF Maintenance and Lubrication Products”, which will be sent on request.

Table 4

Position and size of dowel pin holes

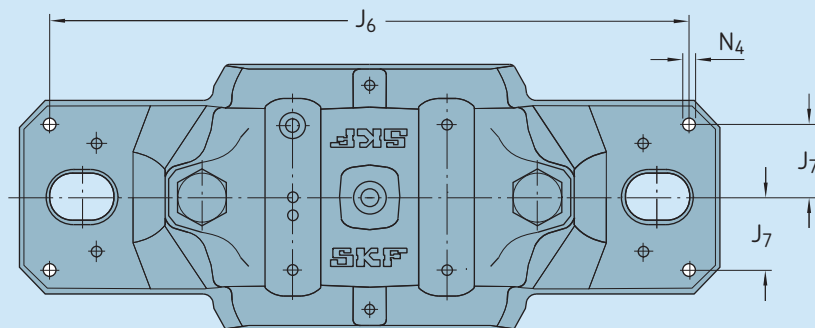

Housing Size	Dimensions			Housing Size	Dimensions		
	J ₆	J ₇	N ₄ max		J ₆	J ₇	N ₄ max
–	mm			–	mm		
SNL 205	152	16	5	SNL 505	152	16	5
SNL 206-305	172	19	5	SNL 506-605	172	19	5
SNL 207	172	19	5	SNL 507-606	172	19	5
SNL 208-307	188	22	6	SNL 508-607	188	22	6
SNL 209	188	22	6	SNL 509	188	22	6
SNL 210	188	22	6	SNL 510-608	188	22	6
SNL 211	234	24,5	8	SNL 511-609	234	24,5	8
SNL 212	234	27	8	SNL 512-610	234	27	8
SNL 213	252	29	8	SNL 513-611	252	29	8
SNL 215	257	29	8	SNL 515-612	257	29	8
SNL 216	288	33	8	SNL 516-613	288	33	8
SNL 217	292	33	8	SNL 517	292	33	8
SNL 218	317	35	8	SNL 518-615	317	35	8
				SNL 519-616	317	35	8
				SNL 520-617	348	39	8
				SNL 522-619	378	44	8
				SNL 524-620	378	44	8
				SNL 526	414	46	12
				SNL 528	458	54	12
				SNL 530	486	58	12
				SNL 532	506	58	12

Mounting bearings on a cylindrical seat

Bearings with a cylindrical bore are normally mounted with an interference fit on the shaft. Appropriate shaft tolerances should be selected.

Small bearings may be mounted cold, driven into position by applying light hammer blows to a sleeve placed against the bearing ring face. The use of a mounting dolly enables the mounting force to be applied centrally.

The force to mount bearings increases considerably with increasing bearing size. Therefore, medium sized bearings should be heated prior to mounting with an SKF electric induction heater.

Support surface for housing base

To provide long bearing service life, SKF recommends that all housing support surfaces be finished to $R_a \leq 12,5 \mu\text{m}$. The flatness (planicity) tolerance should be to IT7. For moderate demands, IT8 may be satisfactory.

Dowel pins

SNL housings are designed for loads acting vertically to the housing base support. If they are to be subjected to moderate or heavy loads, acting parallel to the base support, a stop should be provided, or the housing should be pinned to its support. Recommendations for the position and size of the holes to accommodate dowel pins are provided in **tables 4 and 5**.

Housings for four-bolt mounting

To attach SNL housings to T-shaped beams, a variant with four oblong holes cast into the mounting base can be supplied. Available sizes are shown in **table 5**. These housings are identified by the series designation FSNL, e.g. FSNL 511-609.

It is also possible to drill four bolt holes in the base of a standard SNL housing. Their positions are indicated by cast dimples. Recommended dimensions are provided in **table 6 on page 34**. SNL housings with four drilled bolt holes can be supplied upon request. These housings are identified by the designation suffix /MS2, e.g. SNL 510-608/MS2.

NOTE: Housings supplied with four drilled holes are not interchangeable with the variant containing four cast oblong bolt holes (FSNL). The size and position of the holes are different.

Table 5

Bolt hole dimensions for four cast oblong bolt holes

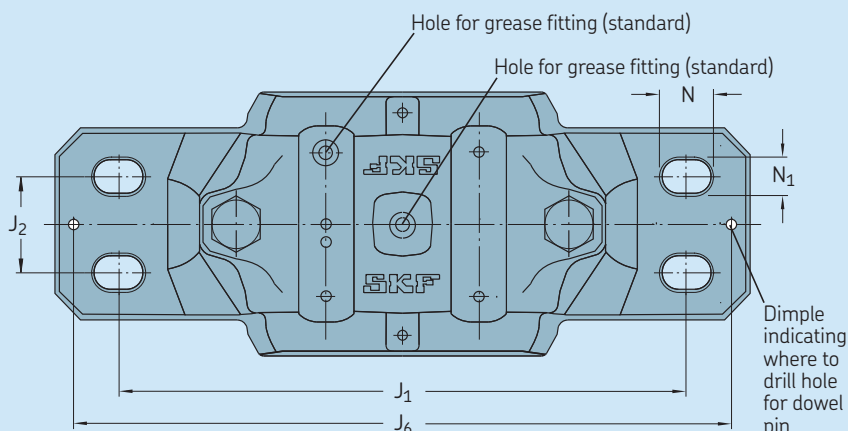

Housing Size	Dimensions				
	N	N ₁	J ₁	J ₂	J ₆
–	mm				
FSNL 511-609	20	15	210	35	234
FSNL 512-610	20	15	210	35	234
FSNL 513-611	20	15	230	40	252
FSNL 515-612	20	15	230	40	257
FSNL 516-613	24	18	260	50	288
FSNL 517	24	18	260	50	292
FSNL 518-615	24	18	290	50	317
FSNL 519-616	24	18	290	50	317
FSNL 520-617	24	18	320	60	348
FSNL 522-619	24	18	350	70	378
FSNL 524-620	24	18	350	70	378
FSNL 526	28	22	380	70	414
FSNL 528	32	26	420	80	458
FSNL 530	32	26	450	90	486
FSNL 532	32	26	470	90	506

Housings for two-bolt mounting

SNL housings are as standard performed with two oblong cast holes with dimensions according to the product tables. If two drilled holes in the base are needed, this can be made provided an SSNLD housing with a blank base is used. Their positions are indicated by cast dimples. Recommended bolt hole dimensions are provided in **table 6 on page 34**. SSNLD housings with two drilled bolt holes can be supplied upon request. These housings are identified by the designation suffix /MS1, e.g. SSNLD 516-613/MS1.

Spheroidal graphite cast iron housings

For applications where extra strength is required, SKF can supply standard design SNL housings in spheroidal graphite cast iron. Sizes range from 510-608 to 532. For additional information → [page 53](#). The housings are available with either four oblong bolt holes cast into the base or a solid base. On special request, housings can be delivered with two or four holes drilled in the base.

If holes will be drilled on-site by the customer, dimples cast into the housing base indicate the optimum location of the hole. Recommended hole dimensions can be found in [table 6](#).

In all other respects these housings are identical to those manufactured in grey cast iron, enabling the same bearings and components to be used.

Spheroidal graphite cast iron housings with a solid base are identified by the series designation SSNLD, e.g. SSNLD 511-609. Housings with four holes cast into the base are identified by the series designation FSNLD, e.g. FSNLD 511-609. Housings with two holes drilled in the base have a designation suffix /MS1, while those with four drilled holes have a designation suffix /MS2, e.g. SSNLD 511-609/MS1 and SSNLD 511-609/MS2, respectively.

Attachment bolts

SKF recommends using 8.8 class hexagonal bolts in accordance with ISO 4014:1999. If the load does not act vertically to the base, it may be necessary to use stronger bolts, class 10.9. Details of the appropriate tightening torques for the bolts to class 8.8 are provided in [table 2](#) on [page 52](#).

Table 6

Bolt hole dimensions for drilled bolt holes

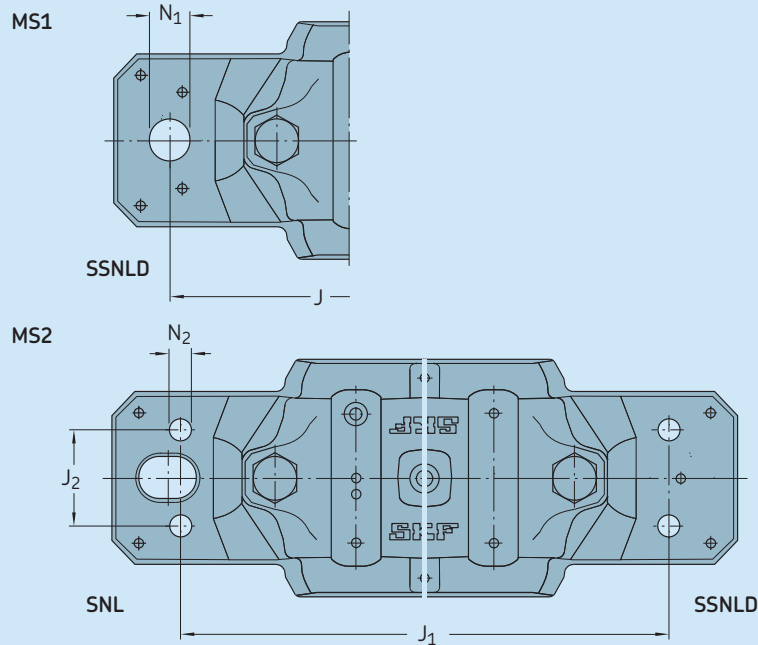

Housing Size	Two bolt holes (MS1) ¹⁾			Four bolt holes (MS2)			Appropriate bolt size	
	Dimensions J	N ₁	Appropriate bolt size	Dimensions J ₁	J ₂	N ₂	mm	in
–	mm		mm in	mm			mm	in
SNL 208-307	–	–	– –	160	34	11	M 10	3/8
SNL 209	–	–	– –	160	34	11	M 10	3/8
(S)SNL(D) 210	170	15	M 12 1/2	160	34	11	M 10	3/8
(S)SNL(D) 211	210	18	M 16 5/8	200	40	14	M 12	1/2
(S)SNL(D) 212	210	18	M 16 5/8	200	40	14	M 12	1/2
(S)SNL(D) 213	230	18	M 16 5/8	220	48	14	M 12	1/2
(S)SNL(D) 215	230	18	M 16 5/8	220	48	14	M 12	1/2
(S)SNL(D) 216	260	22	M 20 3/4	252	52	18	M 16	5/8
(S)SNL(D) 217	260	22	M 20 3/4	252	52	18	M 16	5/8
(S)SNL(D) 218	290	22	M 20 3/4	280	58	18	M 16	5/8
SNL 508-607	–	–	– –	160	34	11	M 10	3/8
SNL 509	–	–	– –	160	34	11	M 10	3/8
(S)SNL(D) 510-608	170	15	M 12 1/2	160	34	11	M 10	3/8
(S)SNL(D) 511-609	210	18	M 16 5/8	200	40	14	M 12	1/2
(S)SNL(D) 512-610	210	18	M 16 5/8	200	40	14	M 12	1/2
(S)SNL(D) 513-611	230	18	M 16 5/8	220	48	14	M 12	1/2
(S)SNL(D) 515-612	230	18	M 16 5/8	220	48	14	M 12	1/2
(S)SNL(D) 516-613	260	22	M 20 3/4	252	52	18	M 16	5/8
(S)SNL(D) 517	260	22	M 20 3/4	252	52	18	M 16	5/8
(S)SNL(D) 518-615	290	22	M 20 3/4	280	58	18	M 16	5/8
(S)SNL(D) 519-616	290	22	M 20 3/4	280	58	18	M 16	5/8
(S)SNL(D) 520-617	320	26	M 24 7/8	300	66	18	M 16	5/8
(S)SNL(D) 522-619	350	26	M 24 7/8	320	74	18	M 16	5/8
(S)SNL(D) 524-620	350	26	M 24 7/8	330	74	18	M 16	5/8
(S)SNL(D) 526	380	28	M 24 1	370	80	22	M 20	3/4
(S)SNL(D) 528	420	35	M 30 1 1/4	400	92	26	M 24	7/8
(S)SNL(D) 530	450	35	M 30 1 1/4	430	100	26	M 24	7/8
(S)SNL(D) 532	470	35	M 30 1 1/4	450	100	26	M 24	7/8

¹⁾ Valid for SSNLD housings only

Mounting SNL housings with four-lip seals

Before starting installation work, the following instructions should be read carefully.

1. Be sure that the work area is clean. Check the dimensional and form accuracy of the shaft seat. The shaft should be machined to a h9/IT5 tolerance for adapter sleeve mounting.
2. Check that the roughness of the support surface is $R_a \leq 12,5 \mu\text{m}$. The flatness (planicity) tolerance should be to IT7. Make sure that the mounting surface is clean. If shims are used, the whole surface must be covered by shims. The mounting surface (frame) must be designed to accommodate actual load, vibrations and settings.
3. Mount any components that are on the shaft between the two SNL housings.
4. If the bearing is mounted on an adapter sleeve, determine its position relative to the housing. For spherical roller bearings with a lubrication groove and three holes in the outer ring, SKF recommends using the relubrication hole in the centre of the housing. When relubrication from the side of the bearing is required such as for CARB toroidal roller bearings or self-aligning ball bearings, the housing must be positioned so that the grease fitting is on the opposite side of the lock nut. When a housing is located at the end of a shaft, grease should be applied at the end cover side.
5. Position the housing on the support surface. Fit the attachment bolts, but do not tighten them.
6. Insert one seal half in each of the grooves in the housing base (If a stepped shaft is used, first mount the distance ring). Fill the space between the two inner sealing lips with grease. If the housing is to be used at the end of a shaft, insert an end cover instead of a seal half.
7. Mount the bearing on the shaft, using an adapter sleeve. Completely fill the bearing with grease. The remainder of the recommended grease quantity should be put in the housing base at the sides (→ **table 1, page 28**).
8. Mount the second bearing and housing, following steps 4 to 7.
9. Lay the shaft with the two bearings in the two housing bases.
10. For locating bearing arrangements and arrangements with CARB toroidal roller bearings, put in one locating ring on each side of the bearing.
11. Carefully align the two housing bases. Vertical markings at the middle of the side faces and ends of the housing bases can facilitate this. Then, lightly tighten the attachment bolts on both housings.
12. The remaining seal halves should be inserted in the seal grooves in the two housing caps and the space between the inner sealing lips filled with grease.
13. Place the two housing caps over each base and tighten the cap bolts (to join cap and base) to the torque specified in **table 2 on page 52**. The cap and base of one housing are not interchangeable with those of other housings. The cap and base of each housing should be checked to see that they bear the same serial number.
14. Check the alignment of the two housings to minimize misalignment and fully tighten the attachment bolts in the two housing bases. Recommended tightening torques are provided in **table 2 on page 52**.

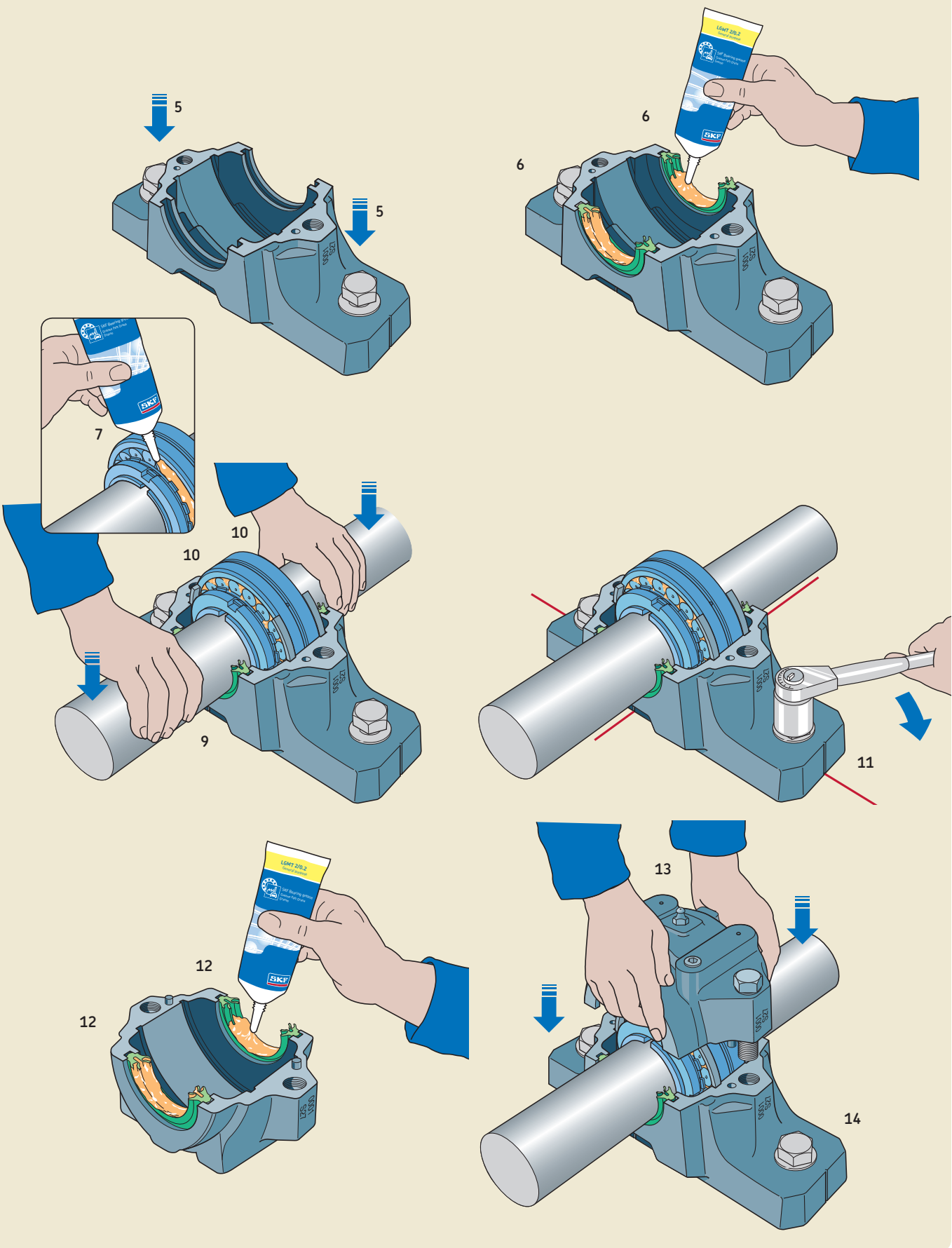

Mounting SNL housings with V-ring seals

Before starting installation work, the following instructions should be read carefully.

1. Be sure that the work area is clean. Check the dimensional and form accuracy of the shaft seat. The shaft should be machined to a h9/IT5 tolerance for adapter sleeve mounting.
2. Check that the roughness of the support surface is $R_a \leq 12,5 \mu\text{m}$. The flatness (planicity) tolerance should be to IT7. Make sure that the mounting surface is clean. If shims are used, the whole surface must be covered by shims. The mounting surface (frame) must be designed to accommodate actual load, vibrations and settings.
3. Mount any components that are on the shaft between the two SNL housings.
4. If the bearing is mounted on an adapter sleeve, determine its position relative to the housing. For spherical roller bearings with a lubrication groove and three holes in the outer ring, SKF recommends using the relubrication hole in the centre of the housing. When relubrication from the side of the bearing is required such as for CARB toroidal roller bearings or self-aligning ball bearings, the housing must be positioned so that the grease fitting is on the opposite side of the lock nut. When a housing is located at the end of a shaft, grease should be applied at the end cover side.
5. Position the housing on the support surface. Fit the attachment bolts, but do not tighten them.
6. Arrange the one V-ring with sealing washer on the shaft. The V-ring should be furthest away from the bearing and seal against the washer, i.e. the lip should point inwards towards the washer.
7. Mount the bearing on the shaft – either directly on a stepped shaft or using an adapter sleeve. Completely fill the bearing with grease. The remainder of the recommended grease quantity should be put in the housing base at the sides (→ **table 1, page 28**).
8. Arrange the second sealing washer and V-ring on the shaft at the other side of the bearing (If a stepped shaft is used, first mount the distance ring). If the housing is to be used at the end of a shaft, mount an end cover instead.
9. Mount the second bearing and housing, following steps 4 to 8.
10. Lay the shaft with the two bearings and sealing washers in the two housing bases.
11. For locating bearing arrangements and arrangements with CARB toroidal roller bearings, put in one locating ring on each side of the bearing.
12. Carefully align the two housing bases. Vertical markings at the middle of the side faces and ends of the housing bases can facilitate this. Then, lightly tighten the attachment bolts on both housings.
13. Place the two housing caps over each base and tighten the cap bolts (to join cap and base) to the torque specified in **table 2 on page 52**. The cap and base of one housing are not interchangeable with those of other housings. The cap and base of each housing should be checked to see that they bear the same serial number.
14. Check the alignment of the two housings to minimize misalignment and fully tighten the attachment bolts in the two housing bases. Recommended tightening torques are provided in **table 2 on page 52**.
15. Coat the V-ring counterfaces on the sealing washers with grease.
16. Finally, push the V-ring seals into their correct position. This can be done using a screwdriver while turning the shaft.

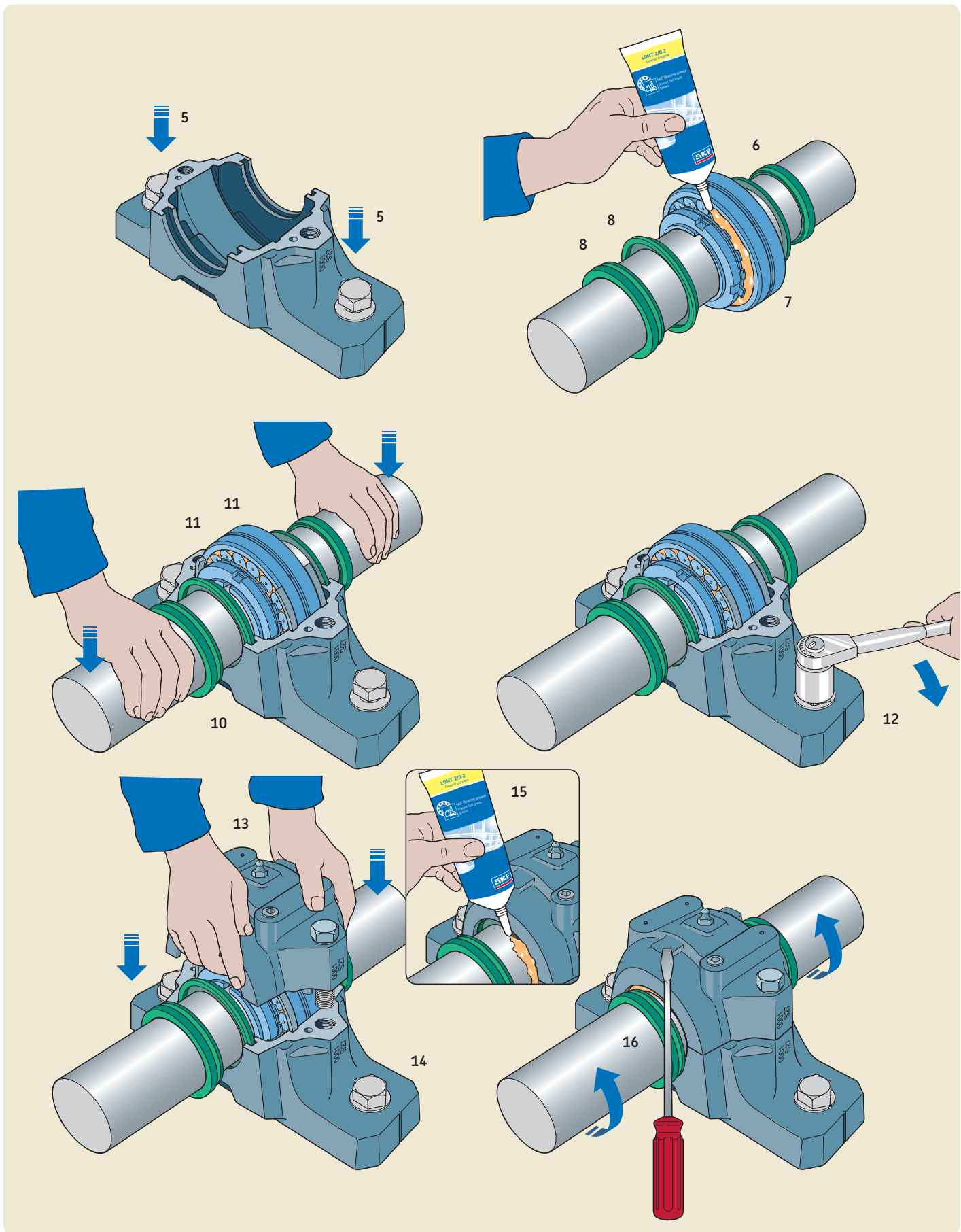

Mounting SNL housings with felt seals

Before starting installation work, the following instructions should be read carefully.

1. Be sure that the work area is clean. Check the dimensional and form accuracy of the shaft seat. The shaft should be machined to a h9/IT5 tolerance for adapter sleeve mounting.
2. Check that the roughness of the support surface is $R_a \leq 12,5 \mu\text{m}$. The flatness (planicity) tolerance should be to IT7. Make sure that the mounting surface is clean. If shims are used, the whole surface must be covered by shims. The mounting surface (frame) must be designed to accommodate actual load, vibrations and settings.
3. Mount any components that are on the shaft between the two SNL housings.
4. If the bearing is mounted on an adapter sleeve, determine its position relative to the housing. For spherical roller bearings with a lubrication groove and three holes in the outer ring, SKF recommends using the relubrication hole in the centre of the housing. When relubrication from the side of the bearing is required such as for CARB toroidal roller bearings or self-aligning ball bearings, the housing must be positioned so that the grease fitting is on the opposite side of the lock nut. When a housing is located at the end of a shaft, grease should be applied at the end cover side.
5. Position the housing on the support surface. Fit the attachment bolts, but do not tighten them.
6. Insert the rubber O-section cords in the grooves in the housing base. If the housing is to be used at the end of a shaft, insert an end cover instead of one O-section cord.
7. Place one felt ring seal half (in light alloy ring) over the O-section cord in each sealing groove in the housing base. (Details about mounting of loose felt strips → **page 18**) (If a stepped shaft is used, first mount the distance ring).
8. Mount the bearing on the shaft – either directly on a stepped shaft or using an adapter sleeve. Completely fill the bearing with grease. The remainder of the recommended grease should be put in the housing base at the sides (→ **table 1, page 28**).
9. Mount the second bearing and housing, following steps 4 to 8.
10. Lay the shaft with the two bearings in the two housing bases.
11. For locating bearing arrangements and arrangements with CARB toroidal roller bearings, put in one locating ring on each side of the bearing.
12. Carefully align the two housing bases. Vertical markings at the middle of the side faces and ends of the housing bases can facilitate this. Then, lightly tighten the attachment bolts on both housings.
13. Put the O-ring cord into the sealing grooves in the two housing caps.
14. The remaining seal halves should be inserted in the seal grooves in the two housing caps over the O-ring cords.
15. Place the two housing caps over each base and tighten the cap bolts (to join cap and base) to the torque specified in **table 2 on page 52**. The cap and base of one housing are not interchangeable with those of other housings. The cap and base of each housing should be checked to see that they bear the same serial number.
16. Check the alignment of the two housings to minimize misalignment and fully tighten the attachment bolts in the two housing bases. Recommended tightening torques are provided in **table 2 on page 52**.

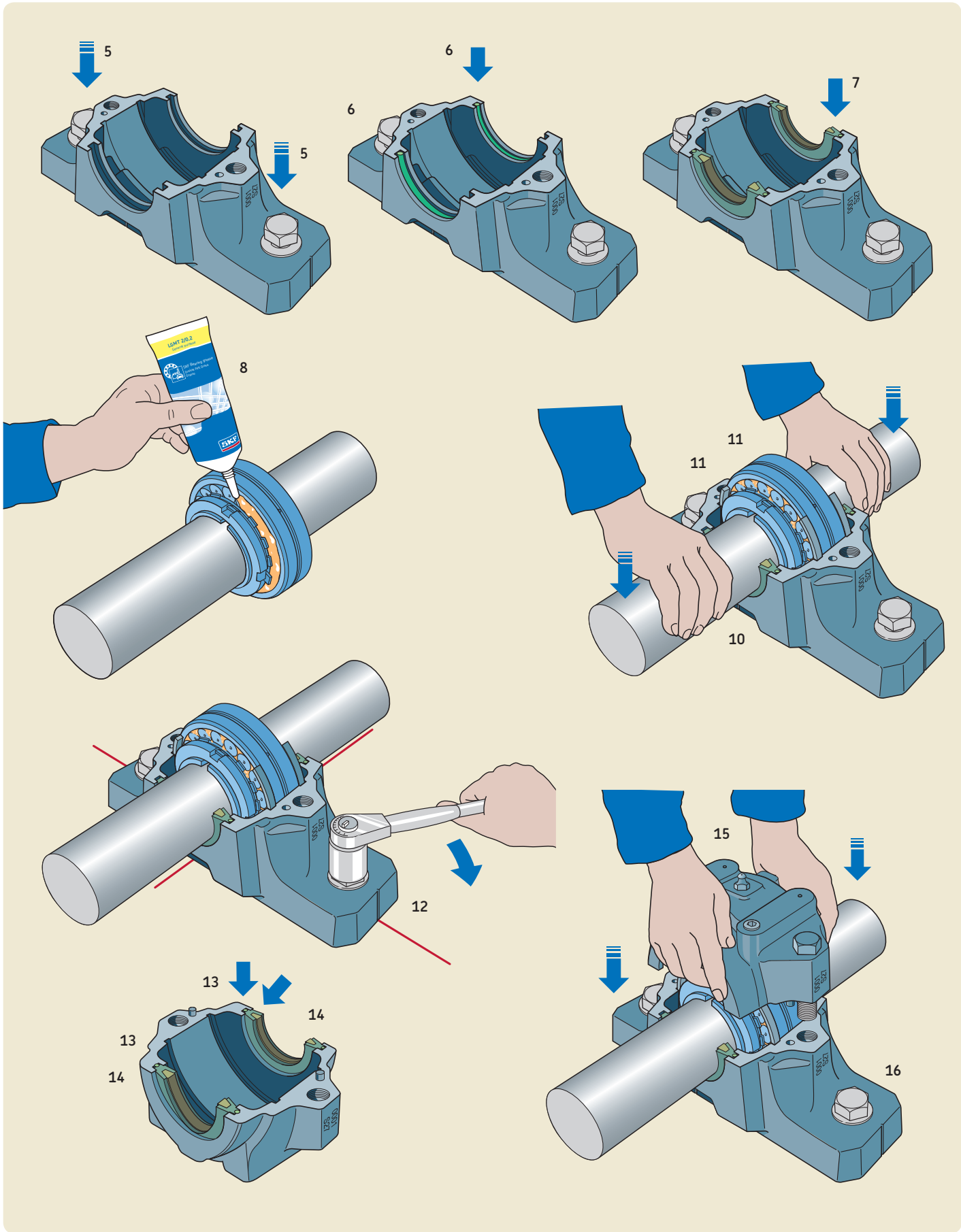

Mounting SNL housings with labyrinth seals

Before starting installation work, the following instructions should be read carefully.

1. Be sure that the work area is clean. Check the dimensional and form accuracy of the shaft seat. The shaft should be machined to a h9/IT5 tolerance for adapter sleeve mounting.
2. Check that the roughness of the support surface is $R_a \leq 12,5 \mu\text{m}$. The flatness (planicity) tolerance should be to IT7. Make sure that the mounting surface is clean. If shims are used, the whole surface must be covered by shims. The mounting surface (frame) must be designed to accommodate actual load, vibrations and settings.
3. Mount any components that are on the shaft between the two SNL housings.
4. If the bearing is mounted on an adapter sleeve, determine its position relative to the housing. For spherical roller bearings with a lubrication groove and three holes in the outer ring, SKF recommends using the relubrication hole in the centre of the housing. When relubrication from the side of the bearing is required such as for CARB toroidal roller bearings or self-aligning ball bearings, the housing must be positioned so that the grease fitting is on the opposite side of the lock nut. When a housing is located at the end of a shaft, grease should be applied at the end cover side.
5. Position the housing on the support surface. Fit the attachment bolts, but do not tighten them.
6. Mount the first labyrinth seal on the shaft in the correct position.
7. Mount the bearing on the shaft – either directly on a stepped shaft or using an adapter sleeve. Completely fill the bearing with grease. The remainder of the recommended grease should be put in the housing base at the sides (→ **table 1, page 28**).
8. Mount the second labyrinth ring on the shaft in the correct position. (If a stepped shaft is used, first mount the distance ring). If the housing is to be used at the end of a shaft, the second seal is omitted and an end cover inserted in the housing base instead.
9. Mount the second bearing and housing, following steps 4 to 8.
10. Lay the shaft with the two bearings and labyrinth rings in the two housing bases.
11. For locating bearing arrangements and arrangements with CARB toroidal roller bearings, put in one locating ring on each side of the bearing.
12. Carefully align the two housing bases. Vertical markings at the middle of the side faces and ends of the housing bases can facilitate this. Then, lightly tighten the attachment bolts on both housings.
13. Place the two housing caps over each base and tighten the cap bolts (to join cap and base) to the torque specified in **table 2 on page 52**. The cap and base of one housing are not interchangeable with those of other housings. The cap and base of each housing should be checked to see that they bear the same serial number.
14. Check the alignment of the two housings to minimize misalignment and fully tighten the attachment bolts in the two housing bases. Recommended tightening torques are provided in **table 2 on page 52**.
15. Finally insert the hollow O-ring cord of synthetic rubber in the grooves in the labyrinth rings. This can be done using a screwdriver while turning the shaft.

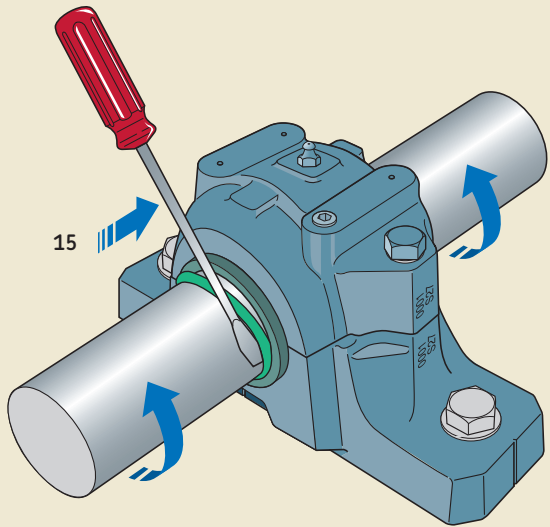
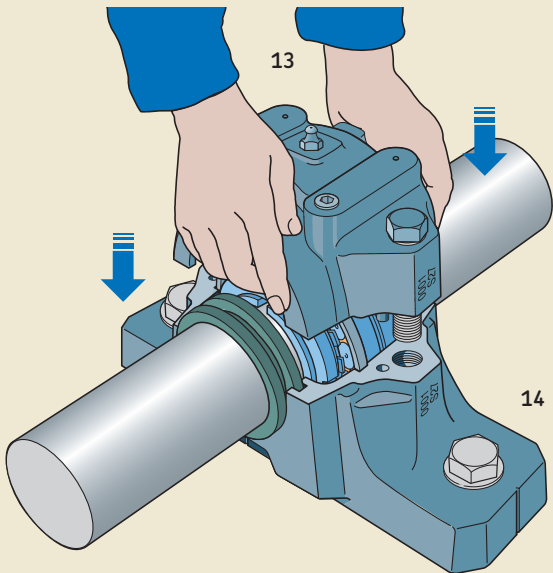
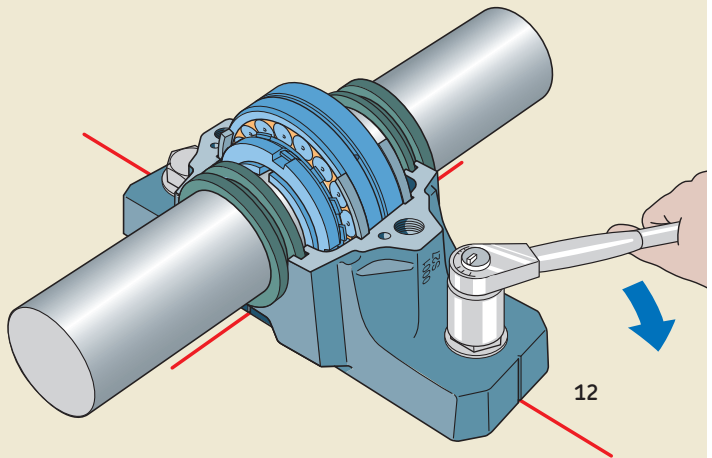
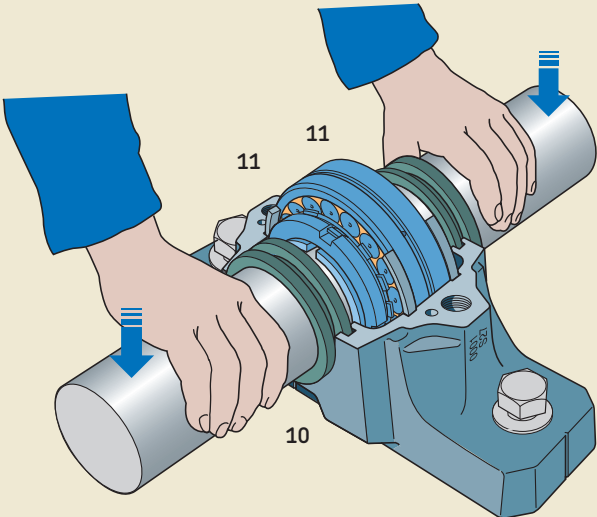
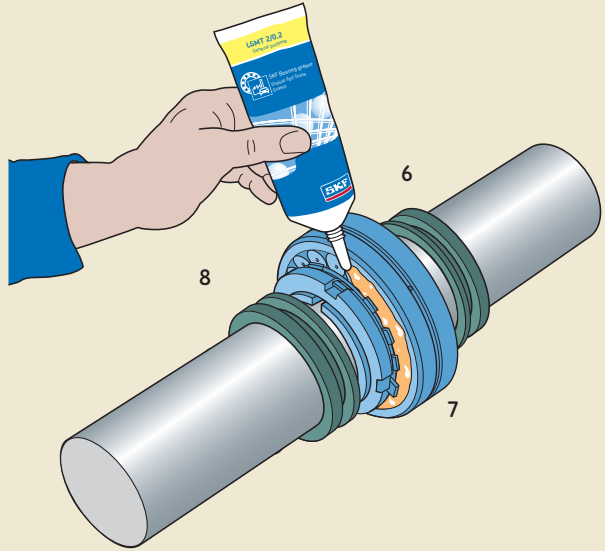
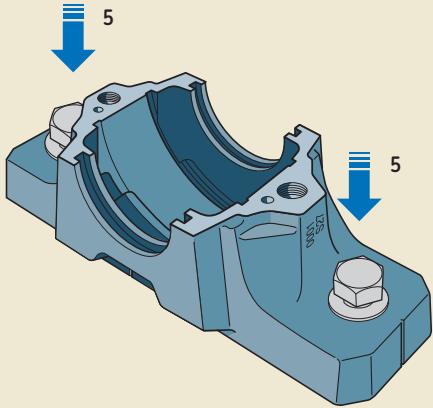

Mounting SNL housings with taconite seals

Before starting installation work, the following instructions should be read carefully.

1. Be sure that the work area is clean. Check the dimensional and form accuracy of the shaft seat. The shaft should be machined to a h9/IT5 tolerance for adapter sleeve mounting.
2. Check that the roughness of the support surface is $R_a \leq 12,5 \mu\text{m}$. The flatness (planicity) tolerance should be to IT7. Make sure that the mounting surface is clean. If shims are used, the whole surface must be covered by shims. The mounting surface (frame) must be designed to accommodate actual load, vibrations and settings.
3. Mount any components that are on the shaft between the two SNL housings.
4. If the bearing is mounted on an adapter sleeve, determine its position relative to the housing. For spherical roller bearings with a lubrication groove and three holes in the outer ring, SKF recommends using the relubrication hole in the centre of the housing. When relubrication from the side of the bearing is required such as for CARB toroidal roller bearings or self-aligning ball bearings, the housing must be positioned so that the grease fitting is on the opposite side of the lock nut. When a housing is located at the end of a shaft, grease should be applied at the end cover side.
5. Position the housing on the support surface. Fit the attachment bolts, but do not tighten them.
6. Mount the first V-ring together with one labyrinth seal on the shaft in the correct position. The lip of the V-ring should point towards the bearing. Place the split ring over the V-ring and labyrinth ring and screw together. The two parts of this split ring are not interchangeable. They should be checked to see that they carry the same serial number.
7. Mount the bearing on the shaft – either directly on a stepped shaft or using an adapter sleeve. Completely fill the bearing with grease. The remainder of the recommended grease should be put in the housing base at the sides (→ **table 1, page 28**).
8. Mount the second seal according to point 6 (If a stepped shaft is used, first mount the distance ring). If the housing is to be used at the end of a shaft, the second seal is omitted and an end cover inserted in the housing base instead.
9. Use the hollow O-section cord to fix the labyrinth ring in position on the shaft. A screwdriver can be used to fit the cords whilst rotating the shaft. Mount the O-ring on the seal outer diameter.
10. Mount the second bearing and housing, following steps 4 to 9.
11. Lay the shaft with the two bearings and seals in the two housing bases taking care that the O-rings are not damaged.
12. For locating bearing arrangements and arrangements with CARB toroidal roller bearings, put in one locating ring on each side of the bearing.
13. Carefully align the two housing bases. Vertical markings at the middle of the side faces and ends of the housing bases can facilitate this. Then, lightly tighten the attachment bolts on both housings.
14. Place the two housing caps over each base and tighten the cap bolts (to join cap and base) to the torque specified in **table 2 on page 52**. The cap and base of one housing are not interchangeable with those of other housings. The cap and base of each housing should be checked to see that they bear the same serial number.
15. Check the alignment of the two housings to minimize misalignment and fully tighten the attachment bolts in the two housing bases. Recommended tightening torques are provided in **table 2 on page 52**.
16. Finally, before the first test run, rotate the shaft and supply grease via the fitting until it exudes from the labyrinth rings. The same grease as that used for the bearings should also be used to lubricate the labyrinth rings.

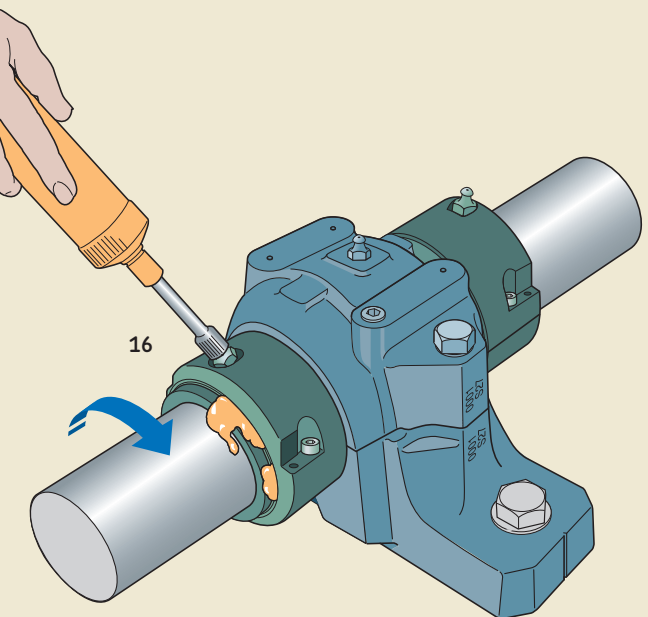
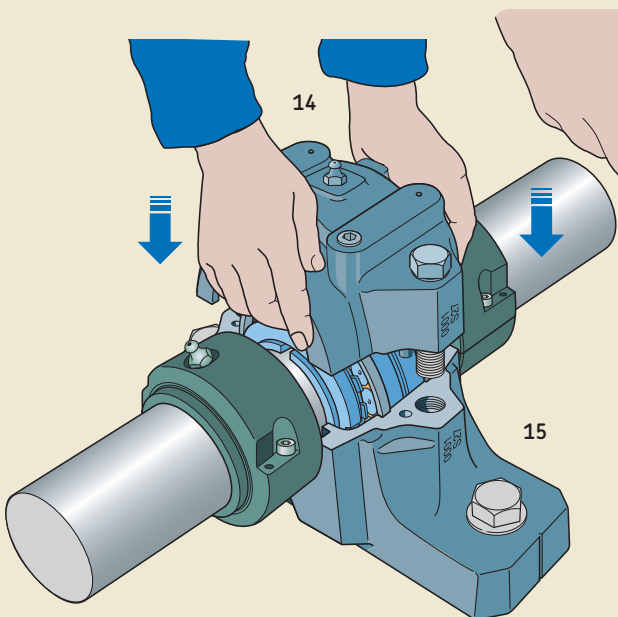
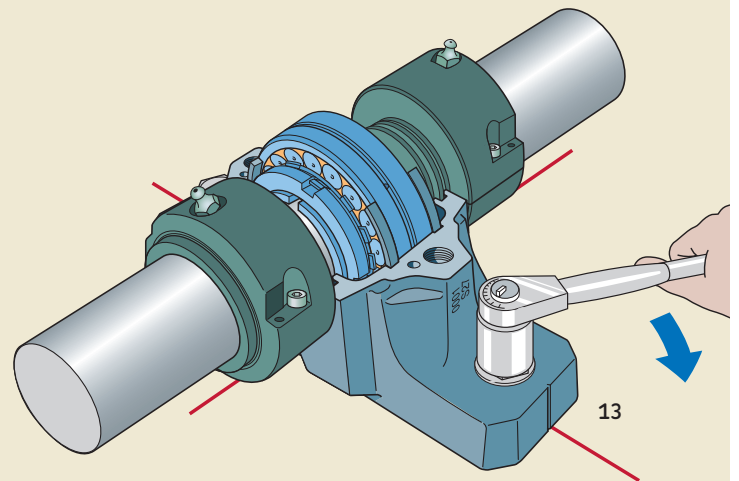
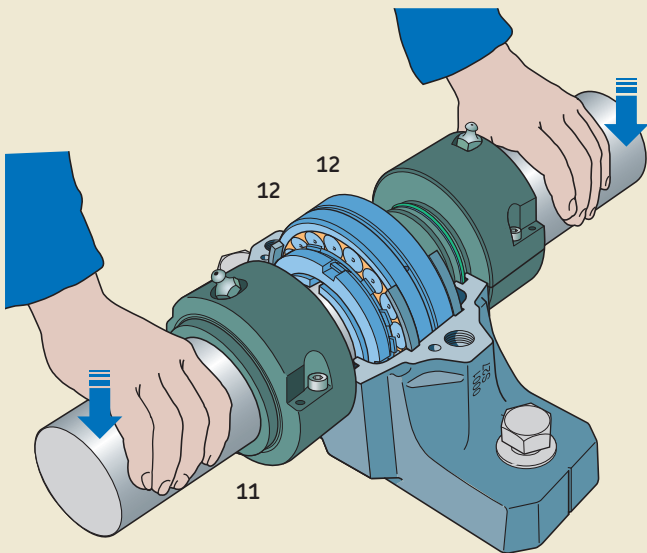
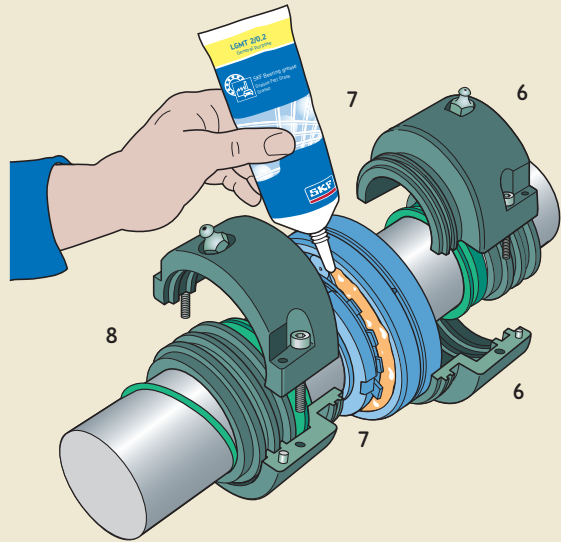
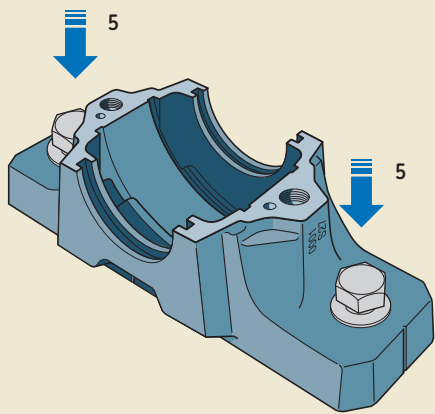

Mounting SNL housings with oil seals

Before starting installation work, the following instructions should be read carefully.

1. Be sure that the work area is clean. Check the dimensional and form accuracy of the shaft seat. The shaft should be machined to a g7/IT5 tolerance for adapter sleeve mounting, and performed with a lead-in chamfer of about 3 mm × 15°.
2. Check that the roughness of the support surface is $R_a \leq 12,5 \mu\text{m}$. The flatness (planicity) tolerance should be to IT7. Make sure that the mounting surface is clean. If the mounting surface is painted, the paint has to be removed. If shims are used, the whole surface must be covered by the shims. The mounting surface (frame) must be designed to accommodate actual load, vibrations and settings.
3. Mount any components that are on the shaft between the two SNL housings.
4. If the bearing is mounted on an adapter sleeve, determine its position relative to the housing.
5. Make sure that the attachment surface of the housing is cleaned from paint and contamination. Positioning the housing base on the support surface. Fit the attachment bolts, but do not tighten them.
6. Assemble the seals. Check if the O-ring and hollow O-ring cord of synthetic rubber are at the right position in their respective grooves (→ **fig. 8** on **page 20**). The dimensions of the hollow O-ring cord of synthetic rubber are 1 × 3 mm.
7. Coat the shaft lightly with a thin oil. Slide the first seal to its right position, some millimetres outside its working position.
8. Mount the bearing on the shaft – either directly on a stepped shaft or using an adapter sleeve.
9. Slide the second seal to the right position on the shaft, as describes in point 7 (If a stepped shaft is used, first mount the distance ring). If the housing is to be used at the end of a shaft, the second seal is omitted and the inner part of the end cover is inserted in the housing base seal groove.
10. Mount the second bearing and housing, following steps 4 to 9.
11. Lay the shaft with the two bearings and seal assemblies in the two housing bases.
12. For locating bearing arrangements and arrangements with CARB toroidal roller bearings, put in one locating ring on each side of the bearing.
13. Carefully align the two housing bases. Vertical markings at the middle of the side faces and ends of the housing bases can facilitate this. Then, lightly tighten the attachment bolts on both housings.
14. Apply a string of oil-resistant sealant, of type Blue Silicone or equal, along the outer contour-line and around the holes, on the housing split surfaces. Then place the two housing caps over each base and tighten the cap bolts (to join cap and base) to the torque specified in **table 2** on **page 52**. The cap and base of one housing are not interchangeable with those of other housings. The cap and base of each housing should be checked to see that they bear the same serial number.
15. Check the alignment of the two housings to minimize misalignment and fully tighten the attachment bolts in the two housing bases. Recommended tightening torques are provided in **table 2** on **page 52**.
16. Slide the seals against the housing side surfaces. Mount the seal mounting screws and tighten them. If an end cover has been mounted fully tighten the screw on the external part of the end cover.
17. Mount the supplied ventilating plugs on the top of the housings and, when oil bath lubrication is used, mount the oil level sight glasses. When circulating oil lubrication is used, connect the oil inlet and outlet pipes to the housing.

Note: It is important that sealant, of type Loctite or equal, is applied on all threads on the supplied accessories.
18. When an oil bath lubrication is used, the maximum and minimum levels should be indicated on the sight glass. Recommended oil levels to be used for the mounted bearings can be found in **table 3** on **page 30**. The oil levels must be read while the application is not operating.

Important: For oil bath lubrication, it is important not to overfill the maximum level as this can cause oil leakage from the housings. For circulating oil, it is important that the outlet pipes can drain the housing in a proper way to avoid overfill of oil inside the housings.
19. Protect the housing assemblies from negative pressure from surrounding equipment.
20. One day after tightening the cap and attachment bolts, make sure that the proper torque was maintained.

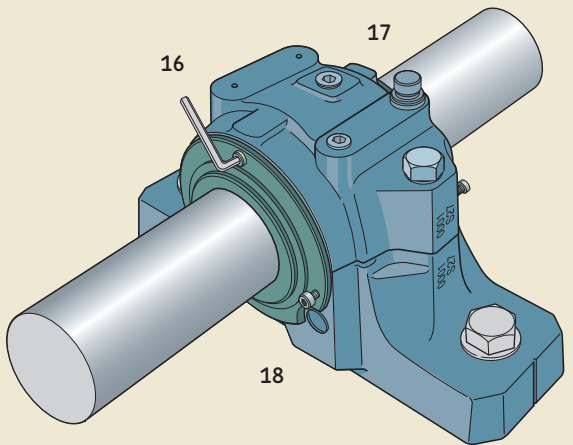
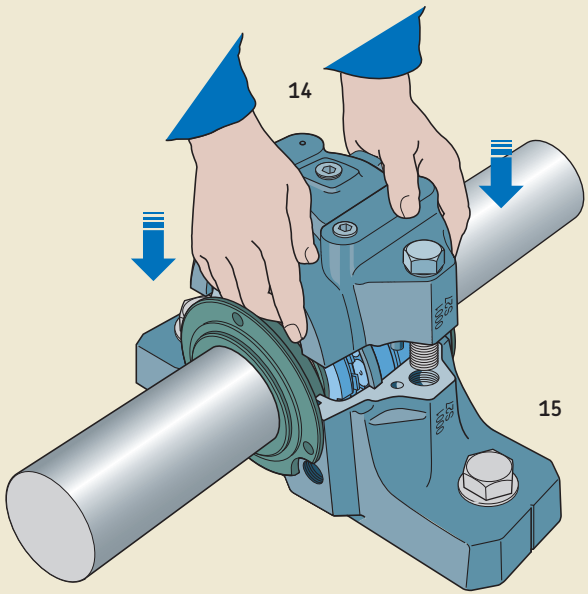
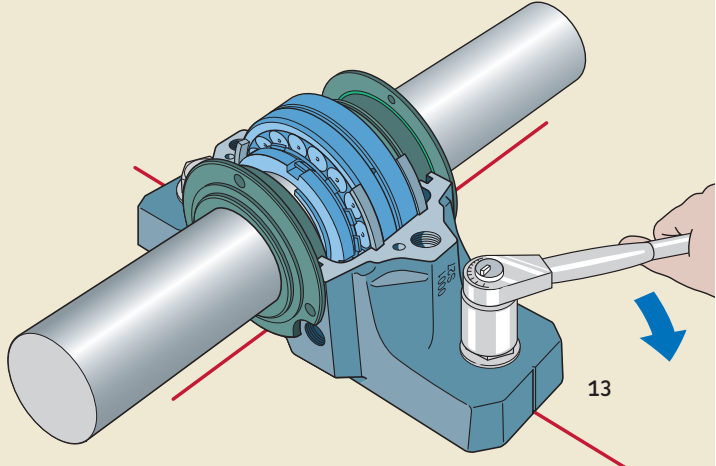
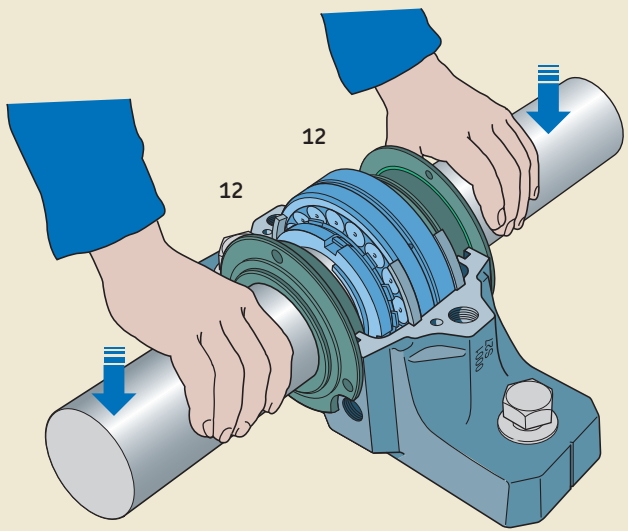
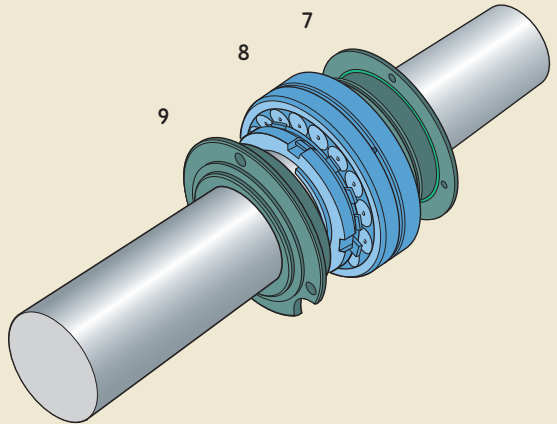
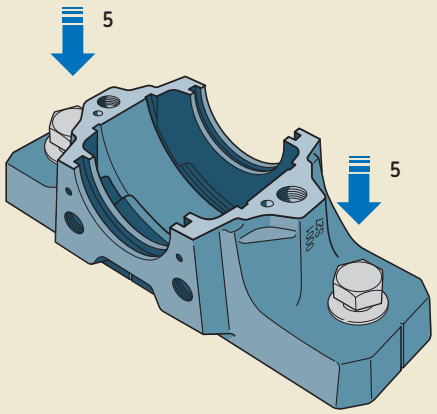

Designations and housing data – general

Designations

SNL housing designations consist of a basic designation that identifies the design, material and size, followed by any supplementary designations needed to identify features that differ from the standard design. A dash (–) in the designation chart indicates that the features belong to the standard design.

Load carrying ability

SNL plummer block housings are intended for loads acting vertically toward the base plate (support). If loads acting in other directions occur, check to be sure that the magnitude of the load is permissible for the housing, for the bolts joining the housing cap and base, and for the attachment bolts.

Load carrying ability of the housing

Guideline values for the breaking load P of the housing for various load directions are provided in **table 1**. The permissible housing load can be obtained from these values by applying a selected safety factor that depends on the operating conditions. In general engineering in Europe, a safety factor of 6 is often used. It is important for the load carrying ability of the

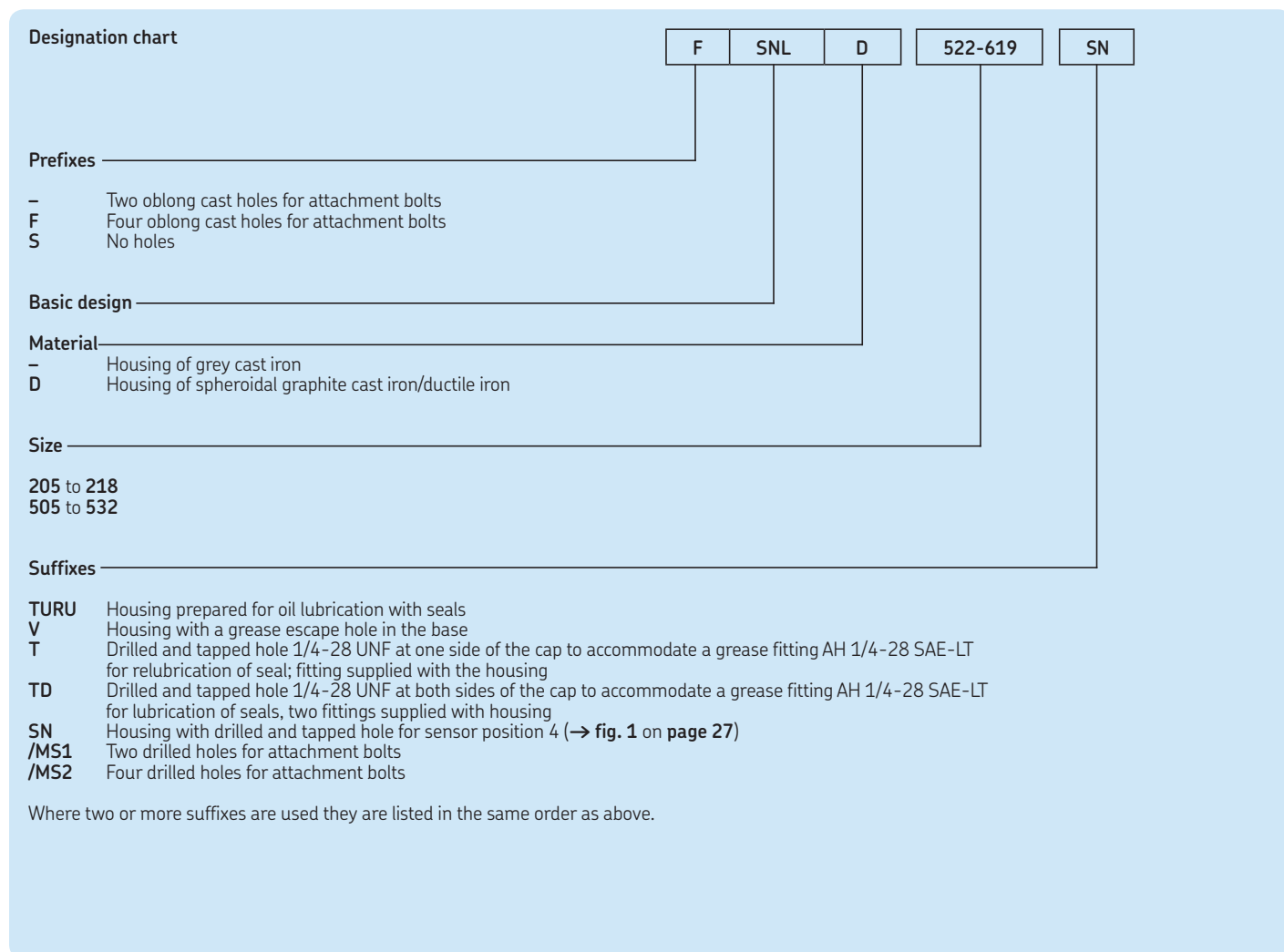

housing that the bolts joining the cap and base are tightened in accordance with the values provided in **table 2** on **page 52**.

The axial load carrying capacity of the housing is approximately 65 % of P_{180° . The housing should be pinned to the support or a stop should be provided in the direction of the load, if one of following conditions apply

- load angles between 55° and 120° exist
- if the axial loads acting parallel to the base plate (support surface) exceed 5 % of P_{180° shown in **table 1**.

Note that P_{0° values are valid only when the housing is not supported in the middle of the base plate i.e. the space between the reinforcement ribs in the base plate.

The axial load carrying capacity of the adapter sleeve must also be considered, see *General Catalogue* for more information.

Load carrying ability of cap bolts

SNL plummer block housings are supplied with 8.8 strength cap bolts as standard. SNL housings made of spheroidal graphite cast iron have 10.9 strength cap bolts. The guideline values for the yield point Q for the cap bolts are provided in **table 2** on **page 52** for various load directions as well as the corresponding maximum radial loads F.

To avoid elastic separation of the cap and base under load, and to resist gradual loosening over time, the cap bolts should be tightened to the torque specifications listed in the table. This is particularly important for housings that are subjected to cyclic loading and dynamic imbalance.

Torque values for cap bolts are general guidelines based on bolt manufacturers' specifications and normal mounting practices where external loads act on the housing base. For applications where external stationary and/or rotating upward loads exist, consult the SKF application engineering service.

Table 1

Breaking loads for SNL plummer block housings

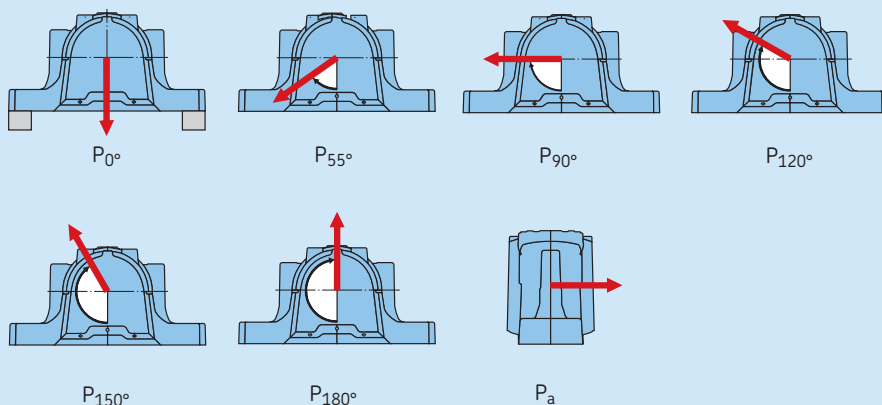

Housing Size	Breaking loads for SNL and FSNL housings						
	P_{0°	P_{55°	P_{90°	P_{120°	P_{150°	P_{180°	P_a
–	kN						
SNL 205	100	155	95	70	60	80	52
SNL 206-305	130	170	100	80	65	85	55
SNL 207	140	190	115	85	80	95	60
SNL 208-307	150	215	130	95	85	110	70
SNL 209	160	230	140	100	90	115	75
SNL 210	170	265	155	120	110	130	85
SNL 211	190	275	170	125	115	140	90
SNL 212	210	300	180	130	120	150	100
SNL 213	270	340	205	150	130	170	110
SNL 215	290	410	250	185	160	205	135
SNL 216	350	430	260	190	175	215	140
SNL 217	370	480	290	205	190	240	155
SNL 218	430	550	340	250	215	275	180
SNL 505	100	155	95	70	60	80	52
SNL 506-605	130	170	100	80	65	85	55
SNL 507-606	140	190	115	85	80	95	60
SNL 508-607	150	215	130	95	85	110	70
SNL 509	160	230	140	100	90	115	75
SNL 510-608	170	265	155	120	110	130	85
(F)SNL 511-609	190	275	170	125	115	140	90
(F)SNL 512-610	210	300	180	130	120	150	100
(F)SNL 513-611	270	340	205	150	130	170	110
(F)SNL 515-612	290	410	250	185	160	205	135
(F)SNL 516-613	350	430	260	190	175	215	140
(F)SNL 517	370	480	290	205	190	240	155
(F)SNL 518-615	430	550	340	250	215	275	180
(F)SNL 519-616	450	580	350	260	230	290	190
(F)SNL 520-617	470	620	370	280	250	310	200
(F)SNL 522-619	600	680	410	310	275	340	220
(F)SNL 524-620	800	790	470	350	320	400	260
(F)SNL 526	900	900	540	410	360	450	295
(F)SNL 528	1 000	1 050	630	470	430	530	345
(F)SNL 530	1 100	1 200	730	540	480	600	390
(F)SNL 532	1 300	1 450	860	640	570	720	470

Table 2

Load carrying ability and tightening torques for cap bolts and attachment bolts

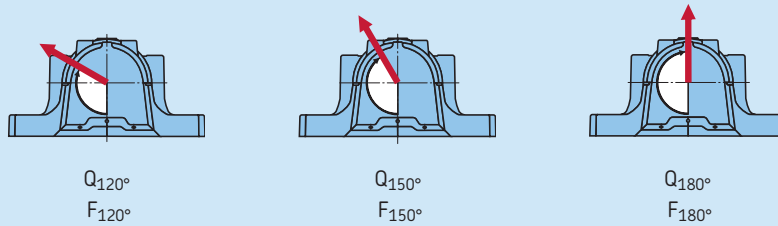

Housing Size	Cap bolts Yield point for both bolts			Maximum load for both bolts			Tightening torque	Designation to ISO 4014	Attachment bolts	
	Q _{120°}	Q _{150°}	Q _{180°}	F _{120°}	F _{150°}	F _{180°}			Size	Tightening torque
–	kN			kN			Nm	–	–	Nm
SNL 205	150	85	75	50	30	25	50	M 10×40	M 12	80
SNL 206-305	150	85	75	50	30	25	50	M 10×40	M 12	80
SNL 207	150	85	75	50	30	25	50	M 10×50	M 12	80
SNL 208-307	150	85	75	50	30	25	50	M 10×50	M 12	80
SNL 209	150	85	75	50	30	25	50	M 10×50	M 12	80
SNL 210	150	85	75	50	30	25	50	M 10×55	M 12	80
SNL 211	220	125	110	80	45	40	80	M 12×60	M 16	200
SNL 212	220	125	110	80	45	40	80	M 12×60	M 16	200
SNL 213	220	125	110	80	45	40	80	M 12×65	M 16	200
SNL 215	220	125	110	80	45	40	80	M 12×65	M 16	200
SNL 216	220	125	110	80	45	40	80	M 12×70	M 20	385
SNL 217	220	125	110	80	45	40	80	M 12×80	M 20	385
SNL 218	400	230	200	170	100	85	150	M 16×90	M 20	385
SNL 505	150	85	75	50	30	25	50	M 10×40	M 12	80
SNL 506-605	150	85	75	50	30	25	50	M 10×40	M 12	80
SNL 507-606	150	85	75	50	30	25	50	M 10×50	M 12	80
SNL 508-607	150	85	75	50	30	25	50	M 10×50	M 12	80
SNL 509	150	85	75	50	30	25	50	M 10×50	M 12	80
SNL 510-608	150	85	75	50	30	25	50	M 10×55	M 12	80
SNL 511-609	220	125	110	80	45	40	80	M 12×60	M 16	200
SNL 512-610	220	125	110	80	45	40	80	M 12×60	M 16	200
SNL 513-611	220	125	110	80	45	40	80	M 12×65	M 16	200
SNL 515-612	220	125	110	80	45	40	80	M 12×65	M 16	200
SNL 516-613	220	125	110	80	45	40	80	M 12×70	M 20	385
SNL 517	220	125	110	80	45	40	80	M 12×80	M 20	385
SNL 518-615	400	230	200	170	100	85	150	M 16×90	M 20	385
SNL 519-616	400	230	200	170	100	85	150	M 16×90	M 20	385
SNL 520-617	620	360	310	260	150	130	200	M 20×100	M 24	665
SNL 522-619	620	360	310	260	150	130	200	M 20×100	M 24	665
SNL 524-620	620	360	310	260	150	130	200	M 20×110	M 24	665
SNL 526	900	520	450	380	220	190	350	M 24×130	M 24	665
SNL 528	900	520	450	380	220	190	350	M 24×130	M 30	1 310
SNL 530	900	520	450	380	220	190	350	M 24×130	M 30	1 310
SNL 532	900	520	450	380	220	190	350	M 24×130	M 30	1 310

Materials

Standard SNL housings are made of grey cast iron. Sizes up to and including 28 comply with EN-GJL-200 specifications. Sizes 30–32 comply with EN-GJL-250 specifications.

For applications where extra strength and resistance are required, SNL housings are also available in spheroidal graphite cast iron that comply with EN-GJS-400-18 specifications. Sizes range from 510–608 to 532 and are dimensionally interchangeable with housings made from grey cast iron. For spheroidal graphite cast iron, the values for P obtained from **table 1** on **page 51** should be multiplied by a factor of 1,8.

These housings are supplied as standard with a solid base, from size 510–608, or with four oblong cast bolt holes in the base, from size 511–609. Spheroidal graphite cast iron housings are designated SSNLD for a solid base, e.g. SSNLD 513–611 or FSNLD for housings with four oblong cast holes, e.g. FSNLD 513–611.

Bearing seat tolerance

SNL housings can be supplied with different bearing seat tolerances. E.g. an interference fit is advantageous for self-aligning bearing systems (spherical roller bearing in the locating position and a CARB bearing in the non-locating position) or if the application is subjected to vibration. For additional information contact the SKF application engineering service.

Painting system

SNL plummer block housings are painted as standard in accordance with ISO 12944-2: 1998, environmental Class C2. Black colour: RAL 9005.

Safe loads

For the American and Canadian markets, the norm is to use safe loads instead of breaking loads. The approximate safe loads for different load directions are provided in **table 3** on **page 54**. These guideline limits have been established using accepted engineering practices with consideration given to safety, ultimate tensile strength of the materials, and

working stresses to reflect a safety factor of 5 against base fracture, and a minimum factor of 2 against cap bolt yield. The housings should be pinned to the support or a stop should be provided in the direction of the load, if one of following conditions apply

- load angles 55° and 120° exist
- if the axial loads acting parallel to the base plate (support surface) exceeds 25 % of the P_{180° value shown in **table 3** on **page 54**.

The maximum permissible axial load that can be safely carried by the housing assembly depends on various considerations in addition to the operational performance abilities of the bearing. For a purely axial load (static or dynamic), the permissible load on the housing should not exceed 65 % of P_{180° value shown in **table 3** on **page 54**.

Table 3

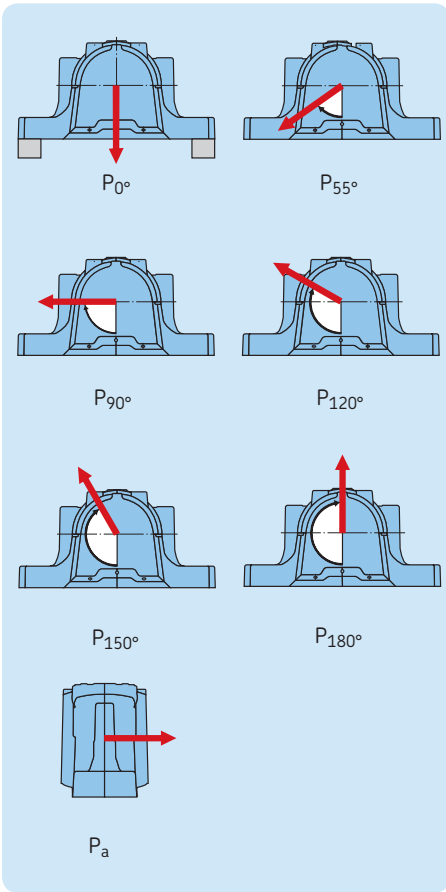

Safe loads for SNL plummer block housings

Housing Size	Safe loads for SNL and FSNL plummer block housings						
	P _{0°}	P _{55°}	P _{90°}	P _{120°}	P _{150°}	P _{180°}	P _a
–	kN/lbf						
SNL 205	20 4 500	31 6 975	19 4 275	14 3 150	12 2 700	16 3 600	10,4 2 340
SNL 206-305	26 5 850	34 7 650	20 4 500	16 3 600	13 2 925	17 3 825	11 2 475
SNL 207	28 6 300	38 8 550	23 5 175	17 3 825	16 3 600	19 4 275	12 2 700
SNL 208-307	30 6 750	43 9 675	26 5 850	19 4 275	17 3 825	22 4 950	14 3 150
SNL 209	32 7 200	46 10 350	28 6 300	20 4 500	18 4 050	23 5 175	15 3 375
SNL 210	34 7 650	53 11 925	31 6 975	24 5 400	22 4 950	26 5 850	17 3 825
SNL 211	38 8 550	55 12 375	34 7 650	25 5 625	23 5 175	28 6 300	18 4 050
SNL 212	42 9 450	60 13 500	36 8 100	26 5 850	24 5 400	30 6 750	20 4 500
SNL 213	54 12 150	68 15 300	41 9 225	30 6 750	26 5 850	34 7 650	22 4 950
SNL 215	58 13 050	82 18 450	50 11 250	37 8 325	32 7 200	41 9 225	27 6 075
SNL 216	70 15 750	86 19 350	52 11 700	38 8 550	35 7 875	43 9 675	28 6 300
SNL 217	74 16 650	96 21 600	58 13 050	41 9 225	38 8 550	48 10 800	31 6 975
SNL 218	86 19 350	110 24 750	68 15 300	50 11 250	43 9 675	55 12 375	36 8 100
SNL 505	20 4 500	31 6 975	19 4 275	14 3 150	12 2 700	16 3 600	10,4 2 340
SNL 506-605	26 5 850	34 7 650	20 4 500	16 3 600	13 2 925	17 3 825	11 2 475
SNL 507-606	28 6 300	38 8 550	23 5 175	17 3 825	16 3 600	19 4 275	12 2 700
SNL 508-607	30 6 750	43 9 675	26 5 850	19 4 275	17 3 825	22 4 950	14 3 150
SNL 509	32 7 200	46 10 350	28 6 300	20 4 500	18 4 050	23 5 175	15 3 375
SNL 510-608	34 7 650	53 11 925	31 6 975	24 5 400	22 4 950	26 5 850	17 3 825
(F)SNL 511-609	38 8 550	55 12 375	34 7 650	25 5 625	23 5 175	28 6 300	18 4 050
(F)SNL 512-610	42 9 450	60 13 500	36 8 100	26 5 850	24 5 400	30 6 750	20 4 500
(F)SNL 513-611	54 12 150	68 15 300	41 9 225	30 6 750	26 5 850	34 7 650	22 4 950
(F)SNL 515-612	58 13 050	82 18 450	50 11 250	37 8 325	32 7 200	41 9 225	27 6 075
(F)SNL 516-613	70 15 750	86 19 350	52 11 700	38 8 550	35 7 875	43 9 675	28 6 300
(F)SNL 517	74 16 650	96 21 600	58 13 050	41 9 225	38 8 550	48 10 800	31 6 975
(F)SNL 518-615	86 19 350	110 24 750	68 15 300	50 11 250	43 9 675	55 12 375	36 8 100
(F)SNL 519-616	90 20 250	116 26 100	70 15 750	52 11 700	46 10 350	58 13 050	38 8 550
(F)SNL 520-617	94 21 150	124 27 900	74 16 650	56 12 600	50 11 250	62 13 950	40 9 000

Safe loads for SNL plummer block housings

Housing Size	Safe loads for SNL and FSNL plummer block housings						
	P _{0°}	P _{55°}	P _{90°}	P _{120°}	P _{150°}	P _{180°}	P _a
–	kN/lbf						
(F)SNL 522-619	120	136	82	62	55	68	44
	27 000	30 600	18 450	13 950	12 375	15 300	9 900
(F)SNL 524-620	160	158	94	70	64	80	52
	36 000	35 550	21 150	15 750	14 400	18 000	11 700
(F)SNL 526	180	180	108	82	72	90	59
	40 500	40 500	24 300	18 450	16 200	20 250	13 275
(F)SNL 528	200	210	126	94	86	106	69
	45 000	47 250	28 350	21 150	19 350	23 850	15 525
(F)SNL 530	220	240	146	108	96	120	78
	49 500	54 000	32 850	24 300	21 600	27 000	17 550
(F)SNL 532	260	290	172	128	114	144	94
	58 500	65 250	38 700	28 800	25 650	32 400	21 150

SNL plummer block housings for bearings on an adapter sleeve, metric shafts

d_a 20 – 35 mm

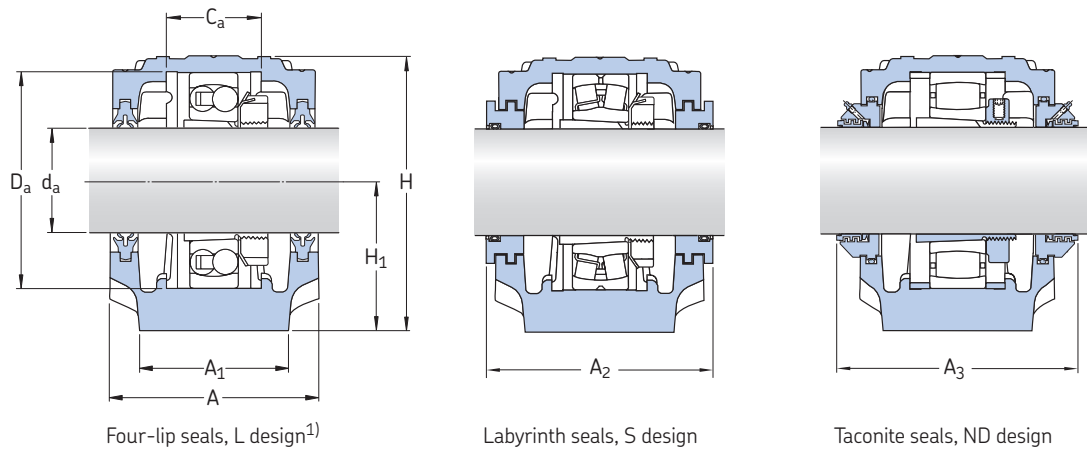

Shaft d_a	Housing Dimensions										Mass kg	Designations Housing	Seals	End cover
	A	A ₁	H	H ₁	H ₂	J	L	N	N ₁	G				
mm	mm										kg	–		
20	67	46	74	40	19	130	165	20	15	12	1,45	SNL 505 SNL 505 SNL 505 SNL 505	TSN 505 A TSN 505 C TSN 505 S TSN 505 ND	ASNH 505 ASNH 505 ASNH 505 ASNH 505
	77	52	89	50	22	150	185	20	15	12	2,00	SNL 506-605 SNL 506-605 SNL 506-605 SNL 506-605	TSN 605 A TSN 605 C TSN 605 S TSN 605 ND	ASNH 506-605 ASNH 506-605 ASNH 506-605 ASNH 506-605
25	77	52	89	50	22	150	185	20	15	12	2,00	SNL 506-605 SNL 506-605 SNL 506-605 SNL 506-605	TSN 506 A TSN 506 C TSN 506 S TSN 506 ND	ASNH 506-605 ASNH 506-605 ASNH 506-605 ASNH 506-605
	82	52	93	50	22	150	185	20	15	12	2,20	SNL 507-606 SNL 507-606 SNL 507-606 SNL 507-606	TSN 606 A TSN 606 C TSN 606 S TSN 606 ND	ASNH 507-606 ASNH 507-606 ASNH 507-606 ASNH 507-606
30	82	52	93	50	22	150	185	20	15	12	2,20	SNL 507-606 SNL 507-606 SNL 507-606 SNL 507-606 SNL 507-606	TSN 507 L TSN 507 A TSN 507 C TSN 507 S TSN 507 ND	ASNH 507-606 ASNH 507-606 ASNH 507-606 ASNH 507-606 ASNH 507-606
	85	60	108	60	25	170	205	20	15	12	2,90	SNL 508-607 SNL 508-607 SNL 508-607 SNL 508-607	TSN 607 A TSN 607 C TSN 607 S TSN 607 ND	ASNH 508-607 ASNH 508-607 ASNH 508-607 ASNH 508-607
35	85	60	108	60	25	170	205	20	15	12	2,90	SNL 508-607 SNL 508-607 SNL 508-607 SNL 508-607 SNL 508-607	TSN 508 L TSN 508 A TSN 508 C TSN 508 S TSN 508 ND	ASNH 508-607 ASNH 508-607 ASNH 508-607 ASNH 508-607 ASNH 508-607
	90	60	113	60	25	170	205	20	15	12	3,20	SNL 510-608 SNL 510-608 SNL 510-608 SNL 510-608	TSN 608 A TSN 608 C TSN 608 S TSN 608 ND	ASNH 510-608 ASNH 510-608 ASNH 510-608 ASNH 510-608

¹⁾ Dimension A remains the same also with C and A seal designs

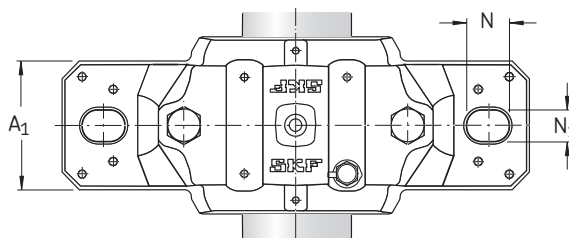
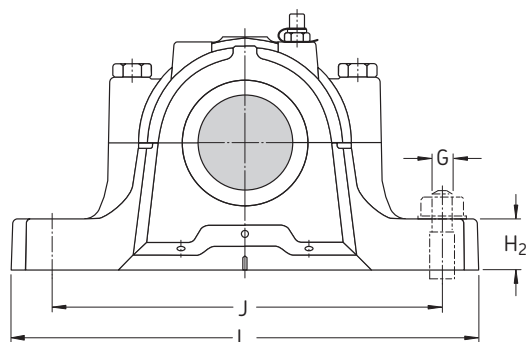

Shaft d_a	Bearing seat		Width across seals		Appropriate bearings and associated components					
	C_a	D_a	A_2	A_3	Self-aligning ball bearing Spherical roller bearing	Adapter sleeve	Locating rings 2 per housing	Self-aligning ball bearing Spherical roller bearing Sealed spherical roller bearing CARB toroidal roller bearing	Adapter sleeve	Locating rings 2 per housing
mm	mm	mm	mm	mm	-					
20	25	52	80	125	1205 EKTN9 -	H 205 -	FRB 5/52 -	2205 EKTN9 22205 EK -	H 305 H 305 -	FRB 3.5/52 FRB 3.5/52 -
		32	62	89	135	1305 EKTN9 -	H 305 -	FRB 7.5/62 -	- - -	- - -
25	32	62	89	135	1206 EKTN9 -	H 206 -	FRB 8/62 -	2206 EKTN9 22206 EK -	H 306 H 306 -	FRB 6/62 FRB 6/62 -
		34	72	94	140	1306 EKTN9 21306 CCK	H 306 H 306	FRB 7.5/72 FRB 7.5/72	2306 K - -	H 2306 - -
30	34	72	94	145	1207 EKTN9 -	H 207 -	FRB 8.5/72 -	2207 EKTN9 22207 EK -	H 307 H 307 -	FRB 5.5/72 FRB 5.5/72 -
		39	80	97	145	1307 EKTN9 21307 CCK	H 307 H 307	FRB 9/80 FRB 9/80	2307 EKTN9 - -	H 2307 - -
35	39	80	97	150	1208 EKTN9 -	H 208 -	FRB 10.5/80 -	2208 EKTN9 22208 EK BS2-2208-2CSK/VT143 C 2208 KTN9	H 308 H 308 H 2308 E H 308 E	FRB 8/80 FRB 8/80 FRB 5.5/80 FRB 8/80
		41	90	102	150	1308 EKTN9 21308 EK	H 308 H 308	FRB 9/90 FRB 9/90	2308 EKTN9 22308 EK - -	H 2308 H 2308 - -

SNL plummer block housings for bearings on an adapter sleeve, metric shafts

d_a 40 – 50 mm

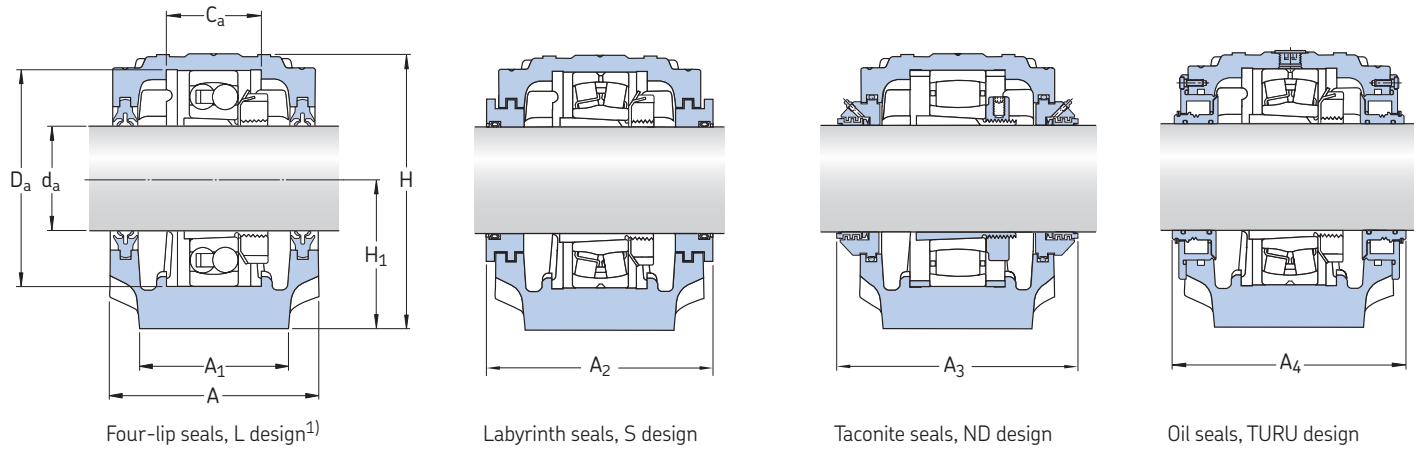

Shaft d_a	Housing Dimensions										Mass kg	Designations Housing	Seals	End cover
	A	A ₁	H	H ₁	H ₂	J	L	N	N ₁	G				
mm	mm										kg	–		
40	85	60	109	60	25	170	205	20	15	12	2,90	SNL 509 SNL 509 SNL 509 SNL 509 SNL 509	TSN 509 L TSN 509 A TSN 509 C TSN 509 S TSN 509 ND	ASNH 509 ASNH 509 ASNH 509 ASNH 509 ASNH 509
	95	70	128	70	28	210	255	24	18	16	4,40	SNL 511-609 SNL 511-609 SNL 511-609 SNL 511-609 SNL 511-609 SNL 609 TURU	TSN 609 L TSN 609 A TSN 609 C TSN 609 S TSN 609 ND included	ASNH 511-609 ASNH 511-609 ASNH 511-609 ASNH 511-609 ASNH 511-609 ASNH 511-609 R
45	90	60	113	60	25	170	205	20	15	12	3,20	SNL 510-608 SNL 510-608 SNL 510-608 SNL 510-608 SNL 510-608	TSN 510 L TSN 510 A TSN 510 C TSN 510 S TSN 510 ND	ASNH 510-608 ASNH 510-608 ASNH 510-608 ASNH 510-608 ASNH 510-608
	105	70	134	70	30	210	255	24	18	16	5,10	SNL 512-610 SNL 512-610 SNL 512-610 SNL 512-610 SNL 512-610 SNL 610 TURU	TSN 610 L TSN 610 A TSN 610 C TSN 610 S TSN 610 ND included	ASNH 512-610 ASNH 512-610 ASNH 512-610 ASNH 512-610 ASNH 512-610 ASNH 512-610 R
50	95	70	128	70	28	210	255	24	18	16	4,40	SNL 511-609 SNL 511-609 SNL 511-609 SNL 511-609 SNL 511-609 SNL 511 TURU	TSN 511 L TSN 511 A TSN 511 C TSN 511 S TSN 511 ND included	ASNH 511-609 ASNH 511-609 ASNH 511-609 ASNH 511-609 ASNH 511-609 ASNH 513-611 R
	110	80	150	80	30	230	275	24	18	16	6,50	SNL 513-611 SNL 513-611 SNL 513-611 SNL 513-611 SNL 513-611 SNL 611 TURU	TSN 611 L TSN 611 A TSN 611 C TSN 611 S TSN 611 ND included	ASNH 513-611 ASNH 513-611 ASNH 513-611 ASNH 513-611 ASNH 513-611 ASNH 513-611 R

¹⁾ Dimension A remains the same also with C and A seal designs

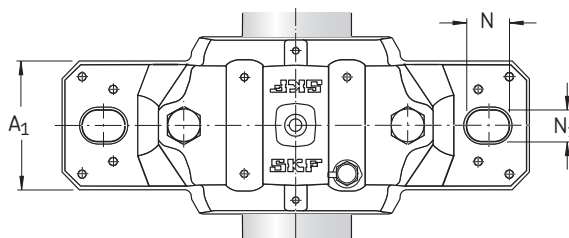
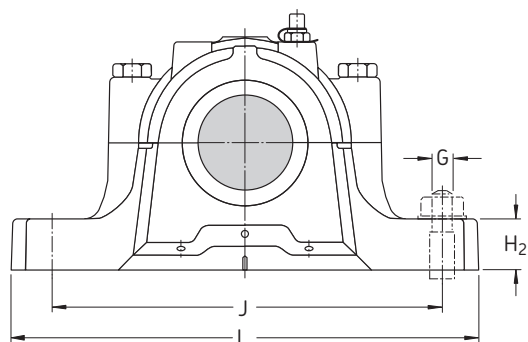

Shaft d_a	Bearing seat		Width across seals			Appropriate bearings and associated components			Self-aligning ball bearing Spherical roller bearing Sealed spherical roller bearing CARB toroidal roller bearing	Adapter sleeve	Locating rings 2 per housing
	C_a	D_a	A_2	A_3	A_4	Self-aligning ball bearing Spherical roller bearing	Adapter sleeve	Locating rings 2 per housing			
mm	mm	mm	mm	mm	mm	mm	mm	mm	mm	mm	
40	30	85	97	150	-	1209 EKTN9 -	H 209 -	FRB 5.5/85 -	2209 EKTN9 22209 EK BS2-2209-2CSK/VT143 C 2209 KTN9	H 309 H 309 H 309 E H 309 E	FRB 3.5/85 FRB 3.5/85 FRB 1/85 FRB 3.5/85
	44	100	107	155	112	1309 EKTN9 21309 EK	H 309 H 309	FRB 9.5/100 FRB 9.5/100	2309 EKTN9 22309 EK -	H 2309 H 2309 -	FRB 4/100 FRB 4/100 -
45	41	90	102	155	-	1210 EKTN9 -	H 210 -	FRB 10.5/90 -	2210 EKTN9 22210 EK BS2-2210-2CSK/VT143 C 2210 KTN9	H 310 H 310 H 310 E H 310 E	FRB 9/90 FRB 9/90 FRB 6.5/90 FRB 9/90
	48	110	117	165	124	1310 EKTN9 21310 EK	H 310 H 310	FRB 10.5/110 FRB 10.5/110	2310 K 22310 EK -	H 2310 H 2310 -	FRB 4/110 FRB 4/110 -
50	44	100	107	165	112	1211 EKTN9 -	H 211 -	FRB 11.5/100 -	2211 EKTN9 22211 EK BS2-2211-2CSK/VT143 C 2211 KTN9	H 311 H 311 H 311 E H 311 E	FRB 9.5/100 FRB 9.5/100 FRB 6.5/100 FRB 9.5/100
	51	120	122	170	128	1311 EKTN9 21311 EK	H 311 H 311	FRB 11/120 FRB 11/120	2311 K 22311 EK -	H 2311 H 2311 -	FRB 4/120 FRB 4/120 -

SNL plummer block housings for bearings on an adapter sleeve, metric shafts

d_a 55 – 65 mm

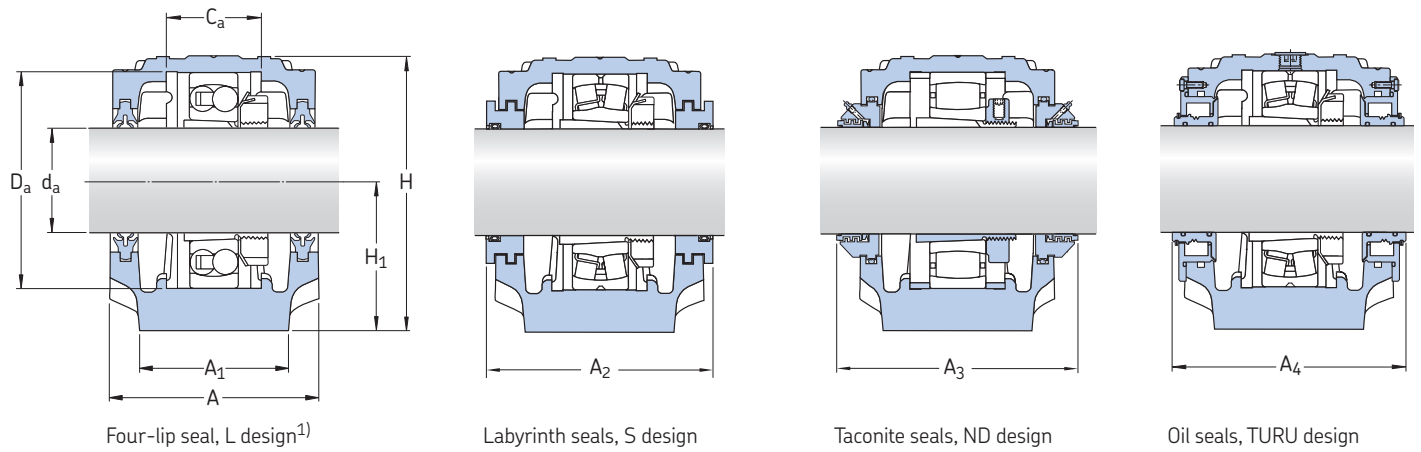

Shaft d_a	Housing Dimensions										Mass kg	Designations Housing	Seals	End cover
	A	A ₁	H	H ₁	H ₂	J	L	N	N ₁	G				
mm	mm										kg	–		
55	105	70	134	70	30	210	255	24	18	16	5,10	SNL 512-610 SNL 512-610 SNL 512-610 SNL 512-610 SNL 512-610 SNL 512 TURU	TSN 512 L TSN 512 A TSN 512 C TSN 512 S TSN 512 ND included	ASNH 512-610 ASNH 512-610 ASNH 512-610 ASNH 512-610 ASNH 512-610 ASNH 515-612 R
	115	80	156	80	30	230	280	24	18	16	7,00	SNL 515-612 SNL 515-612 SNL 515-612 SNL 515-612 SNL 515-612 SNL 612 TURU	TSN 612 L TSN 612 A TSN 612 C TSN 612 S TSN 612 ND included	ASNH 515-612 ASNH 515-612 ASNH 515-612 ASNH 515-612 ASNH 515-612 ASNH 515-612 R
60	110	80	149	80	30	230	275	24	18	16	6,50	SNL 513-611 SNL 513-611 SNL 513-611 SNL 513-611 SNL 513-611 SNL 513 TURU	TSN 513 L TSN 513 A TSN 513 C TSN 513 S TSN 513 ND included	ASNH 513-611 ASNH 513-611 ASNH 513-611 ASNH 513-611 ASNH 513-611 ASNH 516-613 R
	120	90	177	95	32	260	315	28	22	20	9,50	SNL 516-613 SNL 516-613 SNL 516-613 SSNL 516-613 SNL 516-613 SNL 613 TURU	TSN 613 L TSN 613 A TSN 613 C TSN 613 S TSN 613 ND included	ASNH 516-613 ASNH 516-613 ASNH 516-613 ASNH 516-613 ASNH 516-613 ASNH 516-613 R
65	115	80	155	80	30	230	280	24	18	16	7,00	SNL 515-612 SNL 515-612 SNL 515-612 SNL 515-612 SNL 515-612 SNL 515 TURU	TSN 515 L TSN 515 A TSN 515 C TSN 515 S TSN 515 ND included	ASNH 515-612 ASNH 515-612 ASNH 515-612 ASNH 515-612 ASNH 515-612 ASNH 518-615 R
	140	100	194	100	35	290	345	28	22	20	12,5	SNL 518-615 SNL 518-615 SNL 518-615 SNL 518-615 SNL 518-615 SNL 615 TURU	TSN 615 L TSN 615 A TSN 615 C TSN 615 S TSN 615 ND included	ASNH 518-615 ASNH 518-615 ASNH 518-615 ASNH 518-615 ASNH 518-615 ASNH 518-615 R

¹) Dimension A remains the same also with C and A seal designs

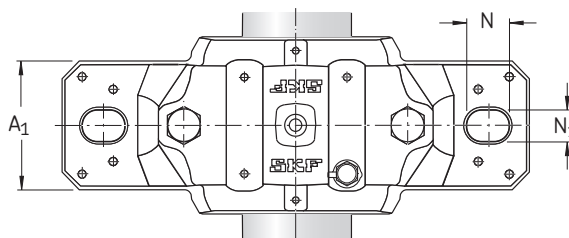
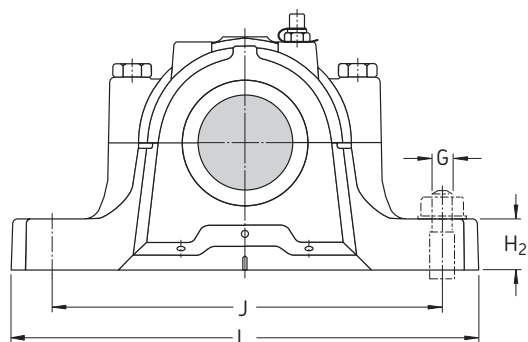

Shaft d_a	Bearing seat		Width across seals			Appropriate bearings and associated components					
	C_a	D_a	A_2	A_3	A_4	Self-aligning ball bearing Spherical roller bearing	Adapter sleeve	Locating rings 2 per housing	Self-aligning ball bearing Spherical roller bearing Sealed spherical roller bearing CARB toroidal roller bearing	Adapter sleeve	Locating rings 2 per housing
mm	mm	mm	mm	mm	mm	—					
55	48	110	117	175	124	1212 EKTN9 —	H 212 —	FRB 13/110 —	2212 EKTN9 22212 EK BS2-2212-2CSK/VT143 C 2212 KTN9	H 312 H 312 H 312 E H 312 E	FRB 10/110 FRB 10/110 FRB 7/110 FRB 10/110
	56	130	127	175	134	1312 EKTN9 21312 EK	H 312 H 312	FRB 12.5/130 FRB 12.5/130	2312 K 22312 EK —	H 2312 H 2312 — —	FRB 5/130 FRB 5/130 — —
60	51	120	122	180	128	1213 EKTN9 —	H 213 —	FRB 14/120 —	2213 EKTN9 22213 EK BS2-2213-2CSK/VT143 C 2213 KTN9	H 313 H 313 H 2313 E H 313 E	FRB 10/120 FRB 10/120 FRB 6,5/120 FRB 10/120
	58	140	138	180	141	1313 EKTN9 21313 EK	H 313 H 313	FRB 12.5/140 FRB 12.5/140	2313 K 22313 EK —	H 2313 H 2313 — —	FRB 5/140 FRB 5/140 — —
65	56	130	127	175	134	1215 K —	H 215 —	FRB 15.5/130 —	2215 EKTN9 22215 EK BS2-2215-2CSK/VT143 C 2215 K	H 315 H 315 H 315 E H 315 E	FRB 12.5/130 FRB 12.5/130 FRB 9/130 FRB 12.5/130
	65	160	158	200	159	1315 K 21315 EK	H 315 H 315	FRB 14/160 FRB 14/160	2315 K 22315 EK — C 2315 K	H 2315 H 2315 — H 2315	FRB 5/160 FRB 5/160 — FRB 5/160

SNL plummer block housings for bearings on an adapter sleeve, metric shafts

d_a 70 – 80 mm

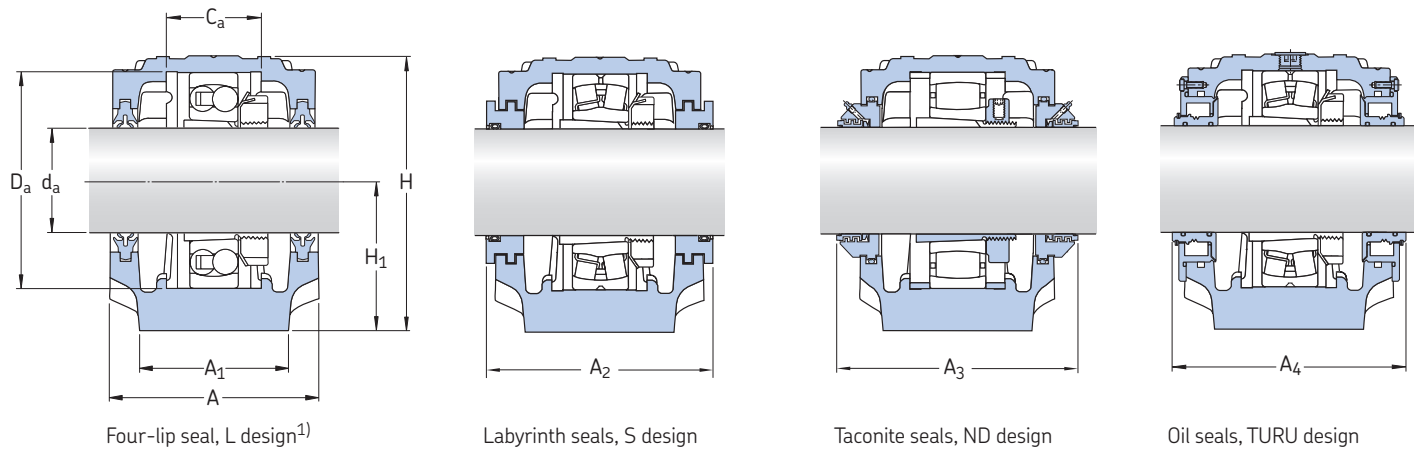

Shaft d_a	Housing Dimensions										Mass kg	Designations Housing	Seals	End cover
	A	A ₁	H	H ₁	H ₂	J	L	N	N ₁	G				
mm	mm										kg	–		
70	120	90	177	95	32	260	315	28	22	20	9,50	SNL 516-613 SNL 516-613 SNL 516-613 SNL 516-613 SNL 516-613 SNL 516 TURU	TSN 516 L TSN 516 A TSN 516 C TSN 516 S TSN 516 ND included	ASNH 516-613 ASNH 516-613 ASNH 516-613 ASNH 516-613 ASNH 516-613 ASNH 216 R
	145	100	212	112	35	290	345	28	22	20	13,7	SNL 519-616 SNL 519-616 SNL 519-616 SNL 519-616 SNL 519-616 SNL 616 TURU	TSN 616 L TSN 616 A TSN 616 C TSN 616 S TSN 616 ND included	ASNH 519-616 ASNH 519-616 ASNH 519-616 ASNH 519-616 ASNH 519-616 ASNH 519-616 R
75	125	90	183	95	32	260	320	28	22	20	10,0	SNL 517 SNL 517 SNL 517 SNL 517 SNL 517 SNL 517 TURU	TSN 517 L TSN 517 A TSN 517 C TSN 517 S TSN 517 ND included	ASNH 517 ASNH 517 ASNH 517 ASNH 517 ASNH 517 ASNH 217 R
	160	110	218	112	40	320	380	32	26	24	17,6	SNL 520-617 SNL 520-617 SNL 520-617 SNL 520-617 SNL 520-617 SNL 617 TURU	TSN 617 L TSN 617 A TSN 617 C TSN 617 S TSN 617 ND included	ASNH 520-617 ASNH 520-617 ASNH 520-617 ASNH 520-617 ASNH 520-617 ASNH 520-617 R
80	140	100	194	100	35	290	345	28	22	20	12,5	SNL 518-615 SNL 518-615 SNL 518-615 SNL 518-615 SNL 518-615 SNL 518 TURU	TSN 518 L TSN 518 A TSN 518 C TSN 518 S TSN 518 ND included	ASNH 518-615 ASNH 518-615 ASNH 518-615 ASNH 518-615 ASNH 518-615 ASNH 218 R

¹⁾ Dimension A remains the same also with C and A seal designs

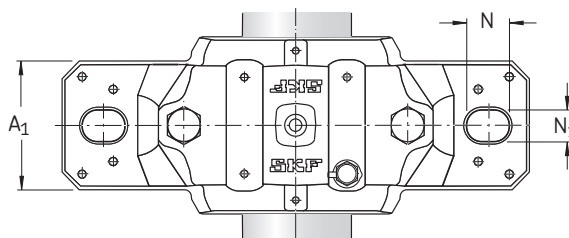
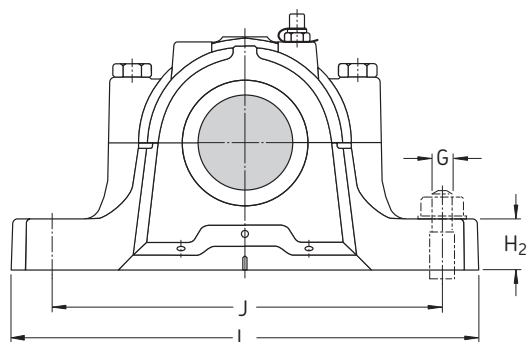

Shaft d_a	Bearing seat		Width across seals			Appropriate bearings and associated components					
	C_a	D_a	A_2	A_3	A_4	Self-aligning ball bearing Spherical roller bearing	Adapter sleeve	Locating rings 2 per housing	Self-aligning ball bearing Spherical roller bearing Sealed spherical roller bearing CARB toroidal roller bearing	Adapter sleeve	Locating rings 2 per housing
mm	mm		mm			-					
70	58	140	138	205	141	1216 K -	H 216 -	FRB 16/140 -	2216 EKTN9 22216 EK BS2-2216-2CSK/VT143 C 2216 K	H 316 H 316 H 316 E H 316 E	FRB 12.5/140 FRB 12.5/140 FRB 9/140 FRB 12.5/140
	68	170	163	205	166	1316 K 21316 EK	H 316 H 316	FRB 14.5/170 FRB 14.5/170	2316 K 22316 EK - C 2316 K	H 2316 H 2316 - H 2316	FRB 5/170 FRB 5/170 - FRB 5/170
75	61	150	143	210	143	1217 K -	H 217 -	FRB 16.5/150 -	2217 K 22217 EK BS2-2217-2CSK/VT143 C 2217 K	H 317 H 317 H 317 E H 317 E	FRB 12.5/150 FRB 12.5/150 FRB 8.5/150 FRB 12.5/150
	70	180	178	220	181	1317 K 21317 EK	H 317 H 317	FRB 14.5/180 FRB 14.5/180	2317 K 22317 EK - C 2317 K	H 2317 H 2317 - H 2317	FRB 5/180 FRB 5/180 - FRB 5/180
80	65	160	158	225	159	1218 K 23218 CCK/W33	H 218 H 2318	FRB 17.5/160 FRB 6.25/160	2218 K 22218 EK BS2-2218-2CSK/VT143 C 2218 K	H 318 H 318 H 2318 E H 318 E	FRB 12.5/160 FRB 12.5/160 FRB 8.5/160 FRB 12.5/160

SNL plummer block housings for bearings on an adapter sleeve, metric shafts

d_a 85 – 110 mm

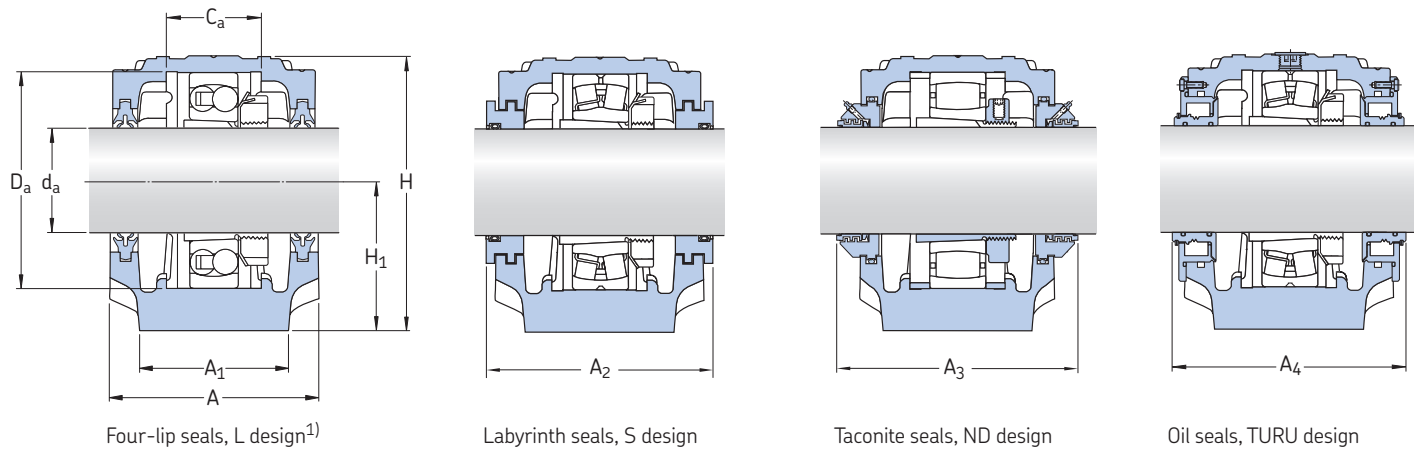

Shaft d_a	Housing Dimensions										Mass	Designations Housing	Seals	End cover
	A	A ₁	H	H ₁	H ₂	J	L	N	N ₁	G				
mm	mm										kg	–		
85	145	100	212	112	35	290	345	28	22	20	13,7	SNL 519-616 SNL 519-616 SNL 519-616 SNL 519-616 SNL 519-616 SNL 519 TURU	TSN 519 L TSN 519 A TSN 519 C TSN 519 S TSN 519 ND included	ASNH 519-616 ASNH 519-616 ASNH 519-616 ASNH 519-616 ASNH 519-616 ASNH 519-616 R
	175	120	242	125	45	350	410	32	26	24	22,0	SNL 522-619 SNL 522-619 SNL 522-619 SNL 522-619 SNL 619 TURU	TSN 619 A TSN 619 C TSN 619 S TSN 619 ND included	ASNH 522-619 ASNH 522-619 ASNH 522-619 ASNH 522-619 ASNH 522-619 R
90	160	110	218	112	40	320	380	32	26	24	17,6	SNL 520-617 SNL 520-617 SNL 520-617 SNL 520-617 SNL 520-617 SNL 520 TURU	TSN 520 L TSN 520 A TSN 520 C TSN 520 S TSN 520 ND included	ASNH 520-617 ASNH 520-617 ASNH 520-617 ASNH 520-617 ASNH 520-617 ASNH 520-617 R
	185	120	271	140	45	350	410	32	26	24	26,2	SNL 524-620 SNL 524-620 SNL 524-620 SNL 524-620 SNL 620 TURU	TSN 620 A TSN 620 C TSN 620 S TSN 620 ND included	ASNH 524-620 ASNH 524-620 ASNH 524-620 ASNH 524-620 ASNH 524-620 R
100	175	120	242	125	45	350	410	32	26	24	22,0	SNL 522-619 SNL 522-619 SNL 522-619 SNL 522-619 SNL 522-619 SNL 522 TURU	TSN 522 L TSN 522 A TSN 522 C TSN 522 S TSN 522 ND included	ASNH 522-619 ASNH 522-619 ASNH 522-619 ASNH 522-619 ASNH 522-619 ASNH 522-619 R
110	185	120	271	140	45	350	410	32	26	24	26,2	SNL 524-620 SNL 524-620 SNL 524-620 SNL 524-620 SNL 524-620 SNL 524 TURU	TSN 524 L TSN 524 A TSN 524 C TSN 524 S TSN 524 ND included	ASNH 524-620 ASNH 524-620 ASNH 524-620 ASNH 524-620 ASNH 524-620 ASNH 524-620 R

¹⁾ Dimension A remains the same also with C and A seal designs

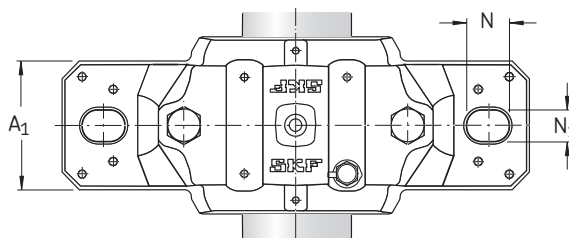
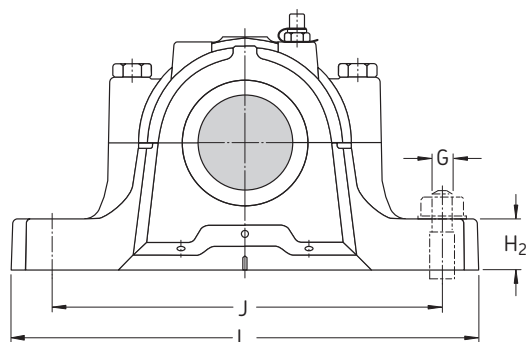

Shaft d_a	Bearing seat		Width across seals			Appropriate bearings and associated components			Self-aligning ball bearing Spherical roller bearing Sealed spherical roller bearing CARB toroidal roller bearing	Adapter sleeve	Locating rings 2 per housing
	C_a	D_a	A_2	A_3	A_4	Self-aligning ball bearing Spherical roller bearing CARB toroidal roller bearing	Adapter sleeve	Locating rings 2 per housing			
mm	mm	mm	mm			–					
85	68	170	163	220	166	1219 K	H 219	FRB 18/170	2219 KM	H 319	FRB 12.5/170
						–	–	–	22219 EK	H 319	FRB 12.5/170
						–	–	–	C 2219 K ¹⁾	H 319 E	FRB 12.5/170
	80	200	191	235	195	1319 K	H 319	FRB 17.5/200	2319 KM	H 2319	FRB 6.5/200
						21319 EK	H 319	FRB 17.5/200	23219 EK	H 2319	FRB 6.5/200
						–	–	–	C 2319 K	H 2319	FRB 6.5/200
90	70	180	178	230	181	1220 K	H 220	FRB 18/180	2220 KM	H 320	FRB 12/180
						23220 CCK/W33	H 2320	FRB 4.85/180	22220 EK	H 320	FRB 12/180
						–	–	–	BS2-2220-2CS5K/VT143	H 2320 E	FRB 7.5/180
						–	–	–	C 2220 K	H 320 E	FRB 12/180
	86	215	199	240	203	1320 K	H 320	FRB 19.5/215	2320 KM	H 2320	FRB 6.5/215
						21320 EK	H 320	FRB 19.5/215	22320 EK	H 2320	FRB 6.5/215
						–	–	–	C 2320 K	H 2320	FRB 6.5/215
100	80	200	191	250	195	1222 K	H 222	FRB 21/200	2222 KM	H 322	FRB 13.5/200
						23222 CCK/W33	H 2322	FRB 5.1/200	22222 EK	H 322	FRB 13.5/200
						–	–	–	BS2-2222-2CS5K/VT143	H 2322 E	FRB 8.5/200
						–	–	–	C 2222 K	H 322 E	FRB 13.5/200
110	86	215	199	260	203	1224 KM	H 3024	FRB 22/215	–	–	–
						23224 CCK/W33	H 2324	FRB 5/215	22224 EK	H 3124	FRB 14/215
						C 2224 K	H 2324 L	FRB 5/215	BS2-2224-2CS5K/VT143	H 2324 E	FRB 8.5/215
						–	–	–	C 2224 K ¹⁾	H 3124 L	FRB 14/215

¹⁾ Check with SKF for availability

SNL plummer block housings for bearings on an adapter sleeve, metric shafts

d_a 115 – 140 mm

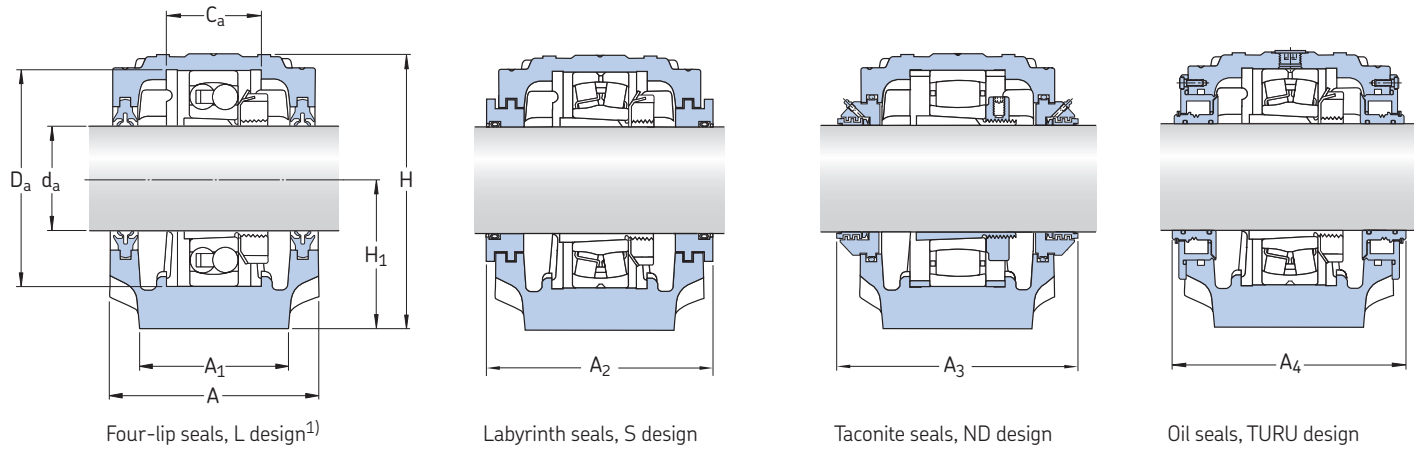

Shaft d_a	Housing Dimensions										Mass kg	Designations Housing	Seals	End cover
	A	A ₁	H	H ₁	H ₂	J	L	N	N ₁	G				
mm	mm										kg	–		
115	190	130	290	150	50	380	445	35	28	24	33,0	SNL 526	TSN 526 L	ASNH 526
												SNL 526	TSN 526 A	ASNH 526
												SNL 526	TSN 526 C	ASNH 526
												SNL 526	TSN 526 S	ASNH 526
												SNL 526	TSN 526 ND	ASNH 526
												SNL 526 TURU	included	ASNH 526 R
125	205	150	302	150	50	420	500	42	35	30	40,0	SNL 528	TSN 528 L	ASNH 528
												SNL 528	TSN 528 A	ASNH 528
												SNL 528	TSN 528 C	ASNH 528
												SNL 528	TSN 528 S	ASNH 528
												SNL 528	TSN 528 ND	ASNH 528
												SNL 528 TURU	included	ASNH 528 R
135	220	160	323	160	60	450	530	42	35	30	49,0	SNL 530	TSN 530 L	ASNH 530
												SNL 530	TSN 530 A	ASNH 530
												SNL 530	TSN 530 C	ASNH 530
												SNL 530	TSN 530 S	ASNH 530
												SNL 530	TSN 530 ND	ASNH 530
												SNL 530 TURU	included	ASNH 530 R
140	235	160	344	170	60	470	550	42	35	30	55,0	SNL 532	TSN 532 L	ASNH 532
												SNL 532	TSN 532 A	ASNH 532
												SNL 532	TSN 532 C	ASNH 532
												SNL 532	TSN 532 S	ASNH 532
												SNL 532	TSN 532 ND	ASNH 532
												SNL 532 TURU	included	ASNH 532 R

¹) Dimension A remains the same also with C and A seal designs

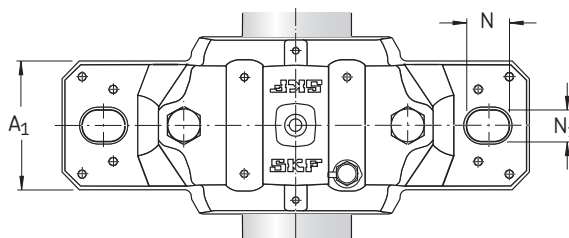
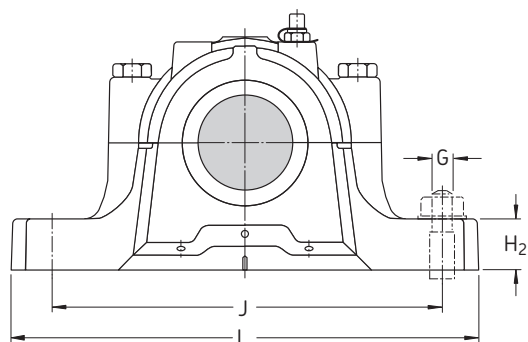

Shaft d_a	Bearing seat		Width across seals			Appropriate bearings and associated components Spherical roller bearing Sealed spherical roller bearing CARB toroidal roller bearing	Adapter sleeve		Locating rings 2 per housing		Spherical roller bearing Sealed spherical roller bearing CARB toroidal roller bearing		Adapter sleeve		Locating rings 2 per housing						
	C_a	D_a	A_2	A_3	A_4		H	L	H	L	H	L	H	L	H	L					
mm	mm	mm	mm	mm	mm	-															
115	90	230	208	265	211	23226 CCK/W33 23226-2CS5K/VT143 -	H 2326 H 2326 L	FRB 5/230 FRB 5/230	22226 EK BS2-2226-2CS5K/VT143 C 2226 K	H 3126 H 2326 E H 3126 L	FRB 13/230 FRB 7.5/230 FRB 13/230										
125	98	250	223	285	225	23228 CCK/W33 23228-2CS5K/VT143 -	H 2328 H 2328	FRB 5/250 FRB 5/250	22228 CCK/W33 22228-2CS5K/VT143 C 2228 K	H 3128 H 3128 L H 3128 L	FRB 15/250 FRB 15/250 FRB 15/250										
135	106	270	241	295	241	23230 CCK/W33 23230-2CS5K/VT143 -	H 2330 H 2330 L	FRB 5/270 FRB 5/270	22230 CCK/W33 22230-2CS5K/VT143 C 2230 K	H 3130 H 3130 H 3130 L	FRB 16.5/270 FRB 16.5/270 FRB 16.5/270										
140	114	290	254	315	257	23232 CCK/W33 - C 3232 K	H 2332 - H 2332 L	FRB 5/290 FRB 5/290	22232 CCK/W33 22232-2CS5K/VT143 -	H 3132 H 3132	FRB 17/290 FRB 17/290										

SNL plummer block housings for bearings on an adapter sleeve, inch shafts

d_a 3/4 – 1 1/8 in

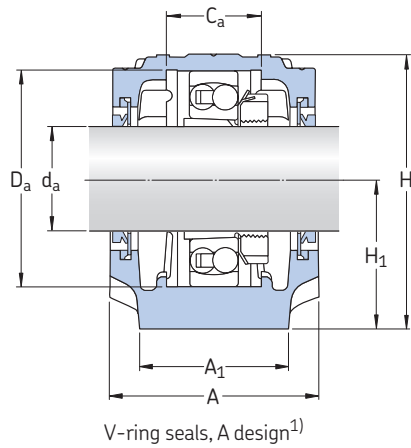

V-ring seals, A design¹⁾

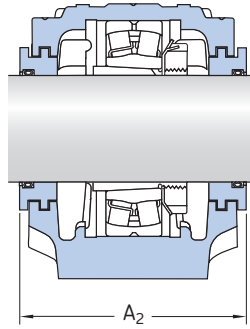

Labyrinth seals, SA/SE/SS design

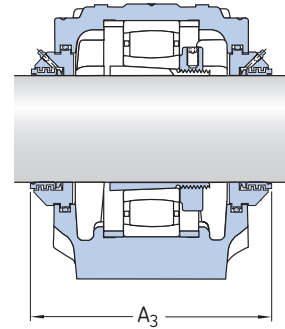

Taconite seals, NDA/NDE/NDS design

Shaft d_a	Housing Dimensions											Mass	Designations Housing	Seals	End cover	
	A	A ₁	H	H ₁	H ₂	J	L	N	N ₁	G	G					
in/mm	mm											in	kg	–		
3/4 19,05	67	46	74	40	19	130	165	20	15	12	1/2	1,45	SNL 505 SNL 505 SNL 505 SNL 505	TSN 505 A TSN 505 C TSN 505 SE TSN 505 NDE	ASNH 505 ASNH 505 ASNH 505 ASNH 505	
	77	52	89	50	22	150	185	20	15	12	1/2	2,00	SNL 506-605 SNL 506-605 SNL 506-605 SNL 506-605	TSN 605 A TSN 605 C TSN 605 SE TSN 605 NDE	ASNH 506-605 ASNH 506-605 ASNH 506-605 ASNH 506-605	
15/16 28,813	77	52	89	50	22	150	185	20	15	12	1/2	2,00	SNL 506-605 SNL 506-605 SNL 506-605 SNL 506-605	TSN 506 A TSN 506 C TSN 506 SA TSN 506 NDA	ASNH 506-605 ASNH 506-605 ASNH 506-605 ASNH 506-605	
	82	52	93	50	22	150	185	20	15	12	1/2	2,20	SNL 507-606 SNL 507-606 SNL 507-606 SNL 507-606	TSN 606 A TSN 606 C TSN 606 SA TSN 606 NDA	ASNH 507-606 ASNH 507-606 ASNH 507-606 ASNH 507-606	
1 25,4	77	52	89	50	22	150	185	20	15	12	1/2	2,00	SNL 506-605 SNL 506-605 SNL 506-605 SNL 506-605	TSN 506 A TSN 506 C TSN 506 SE TSN 506 NDE	ASNH 506-605 ASNH 506-605 ASNH 506-605 ASNH 506-605	
	82	52	93	50	22	150	185	20	15	12	1/2	2,20	SNL 507-606 SNL 507-606 SNL 507-606 SNL 507-606	TSN 606 A TSN 606 C TSN 606 SE TSN 606 NDE	ASNH 507-606 ASNH 507-606 ASNH 507-606 ASNH 507-606	
1 1/8 28,575	82	52	93	50	22	150	185	20	15	12	1/2	2,20	SNL 507-606 SNL 507-606 SNL 507-606 SNL 507-606	TSN 507 A TSN 507 C TSN 507 SS TSN 507 NDS	ASNH 507-606 ASNH 507-606 ASNH 507-606 ASNH 507-606	
	85	60	108	60	25	170	205	20	15	12	1/2	2,90	SNL 508-607 SNL 508-607 SNL 508-607 SNL 508-607	TSN 607 A TSN 607 C TSN 607 SS TSN 607 NDS	ASNH 508-607 ASNH 508-607 ASNH 508-607 ASNH 508-607	

¹⁾ Dimension A remains the same also with C/CE seal design

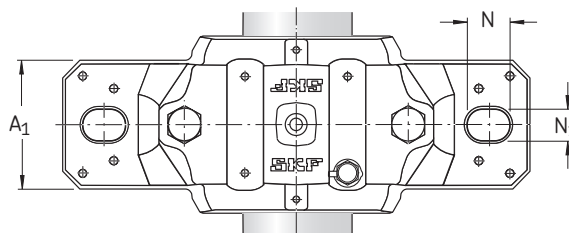
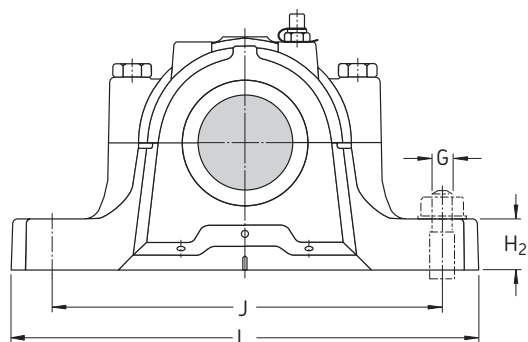

Shaft d_a	Bearing seat		Width across seals		Appropriate bearings and associated components					
	C_a	D_a	A_2	A_3	Self-aligning ball bearing Spherical roller bearing	Adapter sleeve	Locating rings 2 per housing	Self-aligning ball bearing Spherical roller bearing CARB toroidal roller bearing	Adapter sleeve	Locating rings 2 per housing
in/mm	mm		mm		-					
$\frac{3}{4}$ 19,05	25	52	80	125	1205 EKTN9 -	HE 205 -	FRB 5/52 -	2205 EKTN9 22205 EK C 2205 KTN9	HE 305 HE 305 HE 305 E	FRB 3.5/52 FRB 3.5/52 FRB 3.5/52
	32	62	89	135	1305 EKTN9 -	HE 305 -	FRB 7.5/62 -	- - -	- - -	- - -
$\frac{15}{16}$ 23,813	32	62	89	135	1206 EKTN9 -	HA 206 -	FRB 8/62 -	2206 EKTN9 22206 EK C 2206 KTN9	HA 306 HA 306 HA 306 E	FRB 6/62 FRB 6/62 FRB 6/62
	34	72	94	140	1306 EKTN9 21306 CCK	HA 306 HA 306	FRB 7.5/72 FRB 7.5/72	2306 K - -	HA 2306 - -	FRB 3.5/72 - -
1 25,4	32	62	89	135	1206 EKTN9 -	HE 206 -	FRB 8/62 -	2206 EKTN9 22206 EK C 2206 KTN9	HE 306 HE 306 HE 306 E	FRB 6/62 FRB 6/62 FRB 6/62
	34	72	94	140	1306 EKTN9 21306 CCK	HE 306 HE 2306	FRB 7.5/72 FRB 7.5/72	2306 K - -	HE 2306 - -	FRB 3.5/72 - -
$1\frac{1}{8}$ 28,575	34	72	94	145	1207 EKTN9 -	HS 207 -	FRB 8.5/72 -	2207 EKTN9 22207 EK C 2207 KTN9	HS 307 HS 307 HS 307 E	FRB 5.5/72 FRB 5.5/72 FRB 5.5/72
	39	80	97	145	1307 EKTN9 21307 CCK	HS 307 HS 307	FRB 9/80 FRB 9/80	2307 EKTN9 - -	HS 2307 - -	FRB 4/80 - -

SNL plummer block housings for bearings on an adapter sleeve, inch shafts

d_a 1 3/16 – 1 7/16 in

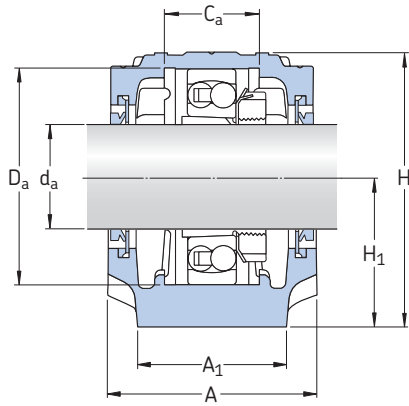

V-ring seals, A/AE design¹⁾

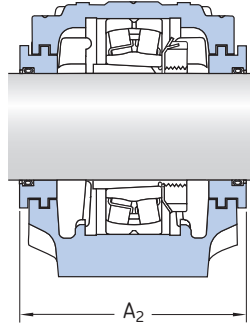

Labyrinth seals, SA/SE/SS design

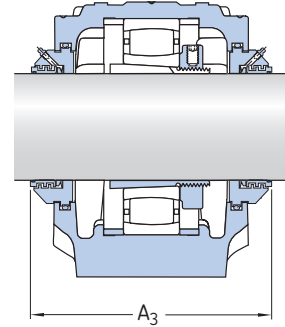

Taconite seals, NDA/NDE/NDS design

Shaft d_a	Housing Dimensions											Mass	Designations Housing	Seals	End cover	
	A	A ₁	H	H ₁	H ₂	J	L	N	N ₁	G	G					
in/mm	mm											in	kg	–		
1 3/16 30,163	82	52	93	50	22	150	185	20	15	12	1/2	2,20	SNL 507-606 SNL 507-606 SNL 507-606 SNL 507-606 SNL 507-606	TSN 507 L TSN 507 A TSN 507 C TSN 507 SA TSNA 507 NDA	ASNH 507-606 ASNH 507-606 ASNH 507-606 ASNH 507-606 ASNH 507-606	
	85	60	108	60	25	170	205	20	15	12	1/2	2,90	SNL 508-607 SNL 508-607 SNL 508-607 SNL 508-607	TSN 607 A TSN 607 C TSN 607 SA TSN 607 NDA	ASNH 508-607 ASNH 508-607 ASNH 508-607 ASNH 508-607	
1 1/4 31,75	85	60	108	60	25	170	205	20	15	12	1/2	2,90	SNL 508-607 SNL 508-607 SNL 508-607 SNL 508-607	TSN 508 AE TSN 508 CE TSN 508 SE TSN 508 NDE	ASNH 508-607 ASNH 508-607 ASNH 508-607 ASNH 508-607	
	90	60	113	60	25	170	205	20	15	12	1/2	3,20	SNL 510-608 SNL 510-608 SNL 510-608 SNL 510-608	TSN 608 AE TSN 608 CE TSN 608 SE TSN 608 NDE	ASNH 510-608 ASNH 510-608 ASNH 510-608 ASNH 510-608	
1 3/8 34,925	85	60	108	60	25	170	205	20	15	12	1/2	2,90	SNL 508-607 SNL 508-607 SNL 508-607 SNL 508-607 SNL 508-607	TSN 508 L TSN 508 A TSN 508 C TSN 508 SS TSN 508 NDS	ASNH 508-607 ASNH 508-607 ASNH 508-607 ASNH 508-607 ASNH 508-607	
	90	60	113	60	25	170	205	20	15	12	1/2	3,20	SNL 510-608 SNL 510-608 SNL 510-608 SNL 510-608	TSN 608 A TSN 608 C TSN 608 SS TSN 608 NDS	ASNH 510-608 ASNH 510-608 ASNH 510-608 ASNH 510-608	
1 7/16 36,513	85	60	109	60	25	170	205	20	15	12	1/2	2,90	SNL 509 SNL 509 SNL 509 SNL 509	TSN 509 AE TSN 509 CE TSN 509 SA TSN 509 NDA	ASNH 509 ASNH 509 ASNH 509 ASNH 509	
	95	70	128	70	28	210	255	24	18	16	5/8	4,40	SNL 511-609 SNL 511-609 SNL 511-609 SNL 511-609	TSN 609 AE TSN 609 CE TSN 609 SA TSN 609 NDA	ASNH 511-609 ASNH 511-609 ASNH 511-609 ASNH 511-609	

¹⁾ Dimension A remains the same also with L and C/CE seal designs

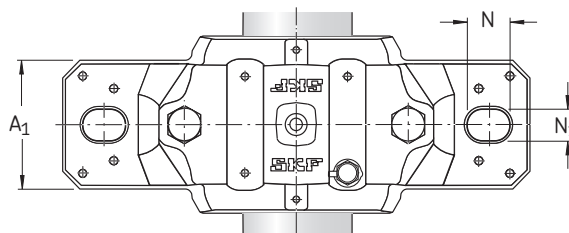
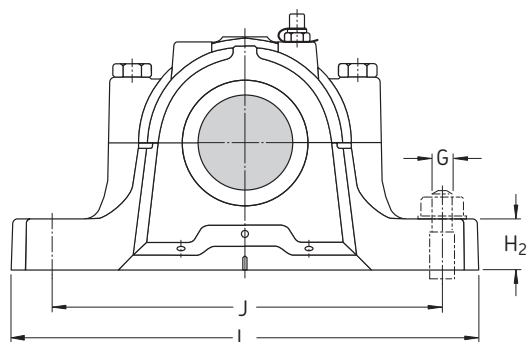

Shaft d_a	Bearing seat		Width across seals		Appropriate bearings and associated components					
	C_a	D_a	A_2	A_3	Self-aligning ball bearing Spherical roller bearing	Adapter sleeve	Locating rings 2 per housing	Self-aligning ball bearing Spherical roller bearing Sealed spherical roller bearing CARB toroidal roller bearing	Adapter sleeve	Locating rings 2 per housing
in/mm	mm		mm		-					
1 3/16 30,163	34	72	94	145	1207 EKTN9	HA 207	FRB 8.5/72	2207 EKTN9	HA 307	FRB 5.5/72
					-	-	-	22207 EK	HA 307	FRB 5.5/72
								C 2207 KTN9	HA 307 E	FRB 5.5/72
	39	80	97	145	1307 EKTN9 21307 CCK	HA 307 HA 307	FRB 9/80 FRB 9/80	2307 EKTN9	HA 2307	FRB 4/80
								-	-	-
								-	-	-
1 1/4 31,75	39	80	97	150	1208 EKTN9	HE 208	FRB 10.5/80	2208 EKTN9	HE 308	FRB 8/80
					-	-	-	22208 EK	HE 308	FRB 8/80
								C 2208 KTN9	HE 308 E	FRB 8/80
	41	90	102	150	1308 EKTN9 21308 EK	HE 308 HE 308	FRB 9/90 FRB 9/90	2308 EKTN9 22308 EK	HE 2308 HE 2308	FRB 4/90 FRB 4/90
								-	-	-
								-	-	-
1 3/8 34,925	39	80	97	150	1208 EKTN9	HS 208	FRB 10,5/80	2208 EKTN9	HS 308	FRB 8/80
					-	-	-	22208 EK	HS 308	FRB 8/80
								BS2-2208-2CSK/VT143	HS 2308 E	FRB 5.5/80
								C 2208 KTN9	HS 308 E	FRB 8/80
	41	90	102	150	1308 EKTN9 21308 EK	HS 308 HS 308	FRB 9/90 FRB 9/90	2308 EKTN9 22308 EK	HS 2308 HS 2308	FRB 4/90 FRB 4/90
								-	-	-
								-	-	-
1 7/16 36,513	30	85	97	150	1209 EKTN9	HA 209	FRB 5.5/85	2209 EKTN9	HA 309	FRB 3.5/85
					-	-	-	22209 EK	HA 309	FRB 3.5/85
								BS2-2209-2CSK/VT143	HA 309 E	FRB 1/85
								C 2209 KTN9	HA 309 E	FRB 3.5/85
	44	100	107	155	1309 EKTN9 21309 EK	HA 309 HA 309	FRB 9.5/100 FRB 9.5/100	2309 EKTN9 22309 EK	HA 2309 HA 2309	FRB 4/100 FRB 4/100
								-	-	-

SNL plummer block housings for bearings on an adapter sleeve, inch shafts

d_a 1 1/2 – 1 15/16 in

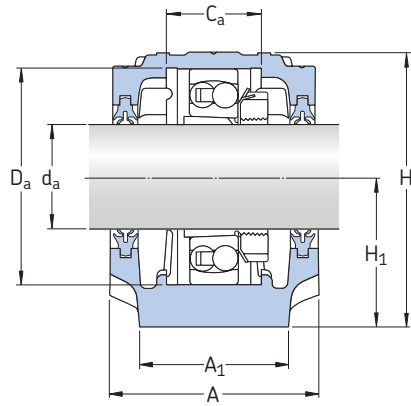

Four-lip seals, L design¹⁾

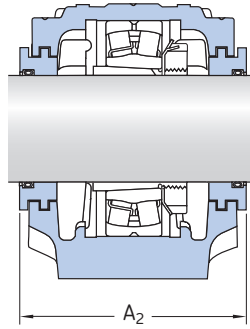

Labyrinth seals, SA/SE design

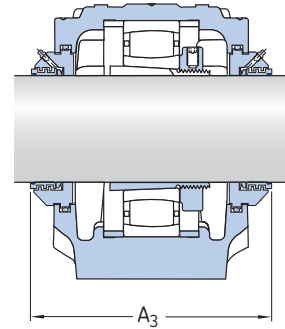

Taconite seals, NDA/NDE design

Shaft d_a	Housing Dimensions											Mass	Designations Housing	Seals	End cover	
	A	A ₁	H	H ₁	H ₂	J	L	N	N ₁	G	G					
in/mm	mm											in	kg	–		
1 1/2 38,1	85	60	109	60	25	170	205	20	15	12	1/2	2,90	SNL 509 SNL 509 SNL 509 SNL 509	TSN 509 AE TSN 509 CE TSN 509 SE TSN 509 NDE	ASNH 509 ASNH 509 ASNH 509 ASNH 509	
	95	70	128	70	28	210	255	24	18	16	5/8	4,40	SNL 511-609 SNL 511-609 SNL 511-609 SNL 511-609	TSN 609 AE TSN 609 CE TSN 609 SE TSN 609 NDE	ASNH 511-609 ASNH 511-609 ASNH 511-609 ASNH 511-609	
1 11/16 42,863	90	60	113	60	25	170	205	20	15	12	1/2	3,20	SNL 510-608 SNL 510-608 SNL 510-608 SNL 510-608	TSN 510 A TSN 510 C TSN 510 SA TSN 510 NDA	ASNH 510-608 ASNH 510-608 ASNH 510-608 ASNH 510-608	
	105	70	134	70	30	210	255	24	18	16	5/8	5,10	SNL 512-610 SNL 512-610 SNL 512-610 SNL 512-610	TSN 610 A TSN 610 C TSN 610 SA TSN 610 NDA	ASNH 512-610 ASNH 512-610 ASNH 512-610 ASNH 512-610	
1 3/4 44,45	90	60	113	60	25	170	205	20	15	12	1/2	3,20	SNL 510-608 SNL 510-608 SNL 510-608 SNL 510-608 SNL 510-608	TSN 510 L TSN 510 A TSN 510 C TSN 510 SE TSN 510 NDE	ASNH 510-608 ASNH 510-608 ASNH 510-608 ASNH 510-608 ASNH 510-608	
	105	70	134	70	30	210	255	24	18	16	5/8	5,10	SNL 512-610 SNL 512-610 SNL 512-610 SNL 512-610 SNL 512-610	TSN 610 L TSN 610 A TSN 610 C TSN 610 SE TSN 610 NDE	ASNH 512-610 ASNH 512-610 ASNH 512-610 ASNH 512-610 ASNH 512-610	
1 15/16 49,213	95	70	128	70	28	210	255	24	18	16	5/8	4,40	SNL 511-609 SNL 511-609 SNL 511-609 SNL 511-609 SNL 511-609	TSN 511 L TSN 511 A TSN 511 C TSN 511 SA TSN 511 NDA	ASNH 511-609 ASNH 511-609 ASNH 511-609 ASNH 511-609 ASNH 511-609	
	110	80	150	80	30	230	275	24	18	16	5/8	6,50	SNL 513-611 SNL 513-611 SNL 513-611 SNL 513-611 SNL 513-611	TSN 611 L TSN 611 A TSN 611 C TSN 611 SA TSN 611 NDA	ASNH 513-611 ASNH 513-611 ASNH 513-611 ASNH 513-611 ASNH 513-611	

¹⁾ Dimension A remains the same also with A/AE and C/CE seal designs

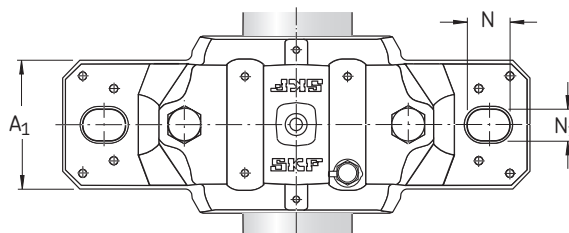
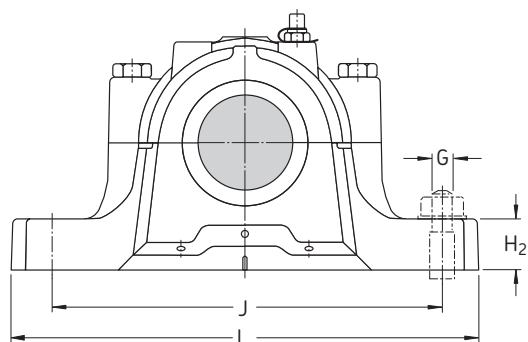

Shaft d_a	Bearing seat		Width across seals		Appropriate bearings and associated components					
	C_a	D_a	A_2	A_3	Self-aligning ball bearing Spherical roller bearing	Adapter sleeve	Locating rings 2 per housing	Self-aligning ball bearing Spherical roller bearing Sealed spherical roller bearing CARB toroidal roller bearing	Adapter sleeve	Locating rings 2 per housing
in/mm	mm		mm		-					
1 1/2 38,1	30	85	97	150	1209 EKTN9 -	HE 209 -	FRB 5.5/85 -	2209 EKTN9 22209 EK BS2-2209-2CSK/VT143 C 2209 KTN9	HE 309 HE 309 HE 309 E HE 309 E	FRB 3.5/85 FRB 3.5/85 FRB 1/85 FRB 3.5/85
	44	100	107	155	1309 EKTN9 21309 EK	HE 309 HE 309	FRB 9.5/100 FRB 9.5/100	2309 EKTN9 22309 EK -	HE 2309 HE 2309 -	FRB 4/100 FRB 4/100 -
1 11/16 42,863	41	90	102	155	1210 EKTN9 -	HA 210 -	FRB 10.5/90 -	2210 EKTN9 22210 EK BS2-2210-2CSK/VT143 C 2210 KTN9	HA 310 HA 310 HA 310 E HA 310 E	FRB 9/90 FRB 9/90 FRB 6.5/90 FRB 9/90
	48	110	117	165	1310 EKTN9 21310 EK	HA 310 HA 310	FRB 10.5/110 FRB 10.5/110	2310 K 22310 EK -	HA 2310 HA 2310 -	FRB 4/110 FRB 4/110 -
1 3/4 44,45	41	90	102	155	1210 EKTN9 -	HE 210 -	FRB 10.5/90 -	2210 EKTN9 22210 EK BS2-2210-2CSK/VT143 C 2210 KTN9	HE 310 HE 310 HE 310 E HE 310 E	FRB 9/90 FRB 9/90 FRB 6.5/90 FRB 9/90
	48	110	117	165	1310 EKTN9 21310 EK	HE 310 HE 310	FRB 10.5/110 FRB 10.5/110	2310 K 22310 EK -	HE 2310 HE 2310 -	FRB 4/110 FRB 4/110 -
1 15/16 49,213	44	100	107	165	1211 EKTN9 -	HA 211 -	FRB 11.5/100 -	2211 EKTN9 22211 EK BS2-2211-2CSK/VT143 C 2211 KTN9	HA 311 HA 311 HA 311 E HA 311 E	FRB 9.5/100 FRB 9.5/100 FRB 6.5/90 FRB 9.5/100
	51	120	122	170	1311 EKTN9 21311 EK	HA 311 HA 311	FRB 11/120 FRB 11/120	2311 K 22311 EK -	HA 2311 HA 2311 -	FRB 4/120 FRB 4/120 -

SNL plummer block housings for bearings on an adapter sleeve, inch shafts

d_a 2 – 2 1/4 in

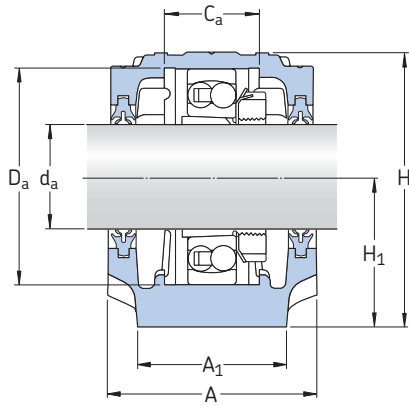

Four-lip seals, L/LA design¹⁾

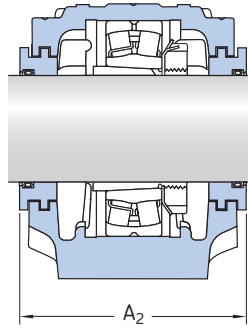

Labyrinth seals, SA/SE/SS design

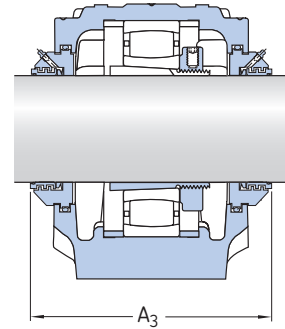

Taconite seals, NDA/NDE/NDS design

Shaft d_a	Housing Dimensions											Mass	Designations Housing	Seals	End cover	
	A	A ₁	H	H ₁	H ₂	J	L	N	N ₁	G	G					
in/mm	mm											in	kg	–		
2 50,8	95	70	128	70	28	210	255	24	18	16	5/8	4,40	SNL 511-609 SNL 511-609 SNL 511-609 SNL 511-609 SNL 511-609	TSN 511 L TSN 511 A TSN 511 C TSN 511 SE TSN 511 NDE	ASNH 511-609 ASNH 511-609 ASNH 511-609 ASNH 511-609 ASNH 511-609	
	110	80	150	80	30	230	275	24	18	16	5/8	6,50	SNL 513-611 SNL 513-611 SNL 513-611 SNL 513-611 SNL 513-611	TSN 611 L TSN 611 A TSN 611 C TSN 611 SE TSN 611 NDE	ASNH 513-611 ASNH 513-611 ASNH 513-611 ASNH 513-611 ASNH 513-611	
2 1/8 53,975	105	70	134	70	30	210	255	24	18	16	5/8	5,10	SNL 512-610 SNL 512-610 SNL 512-610 SNL 512-610	TSN 512 A TSN 512 C TSN 512 SS TSN 512 NDS	ASNH 512-610 ASNH 512-610v ASNH 512-610 ASNH 512-610	
	115	80	156	80	30	230	280	24	18	16	5/8	7,00	SNL515-612 SNL515-612 SNL515-612 SNL515-612	TSN 612 A TSN 612 C TSN 612 SS TSN 612 NDS	ASNH 515-612 ASNH 515-612 ASNH 515-612 ASNH 515-612	
2 3/16 55,563	110	80	149	80	30	230	275	24	18	16	5/8	6,50	SNL 513-611 SNL 513-611 SNL 513-611 SNL 513-611 SNL 513-611	TSN 513 LA TSN 513 AE TSN 513 CE TSN 513 SA TSN 513 NDA	ASNH 513-611 ASNH 513-611 ASNH 513-611 ASNH 513-611 ASNH 513-611	
	120	90	177	95	32	260	315	28	22	20	3/4	9,50	SNL 516-613 SNL 516-613 SNL 516-613 SNL 516-613	TSN 613 AE TSN 613 CE TSN 613 SA TSN 613 NDA	ASNH 516-613 ASNH 516-613 ASNH 516-613 ASNH 516-613	
2 1/4 57,15	110	80	149	80	30	230	275	24	18	16	5/8	6,50	SNL 513-611 SNL 513-611 SNL 513-611 SNL 513-611	TSN 513 A TSN 513 CE TSN 513 SE TSN 513 NDE	ASNH 513-611 ASNH 513-611 ASNH 513-611 ASNH 513-611	
	120	90	177	95	32	260	315	28	22	20	3/4	9,50	SNL 516-613 SNL 516-613 SNL 516-613 SNL 516-613	TSN 613 A TSN 613 CE TSN 613 SE TSN 613 NDE	ASNH 516-613 ASNH 516-613 ASNH 516-613 ASNH 516-613	

¹⁾ Dimension A remains the same also with A/AE and C/CE seal designs

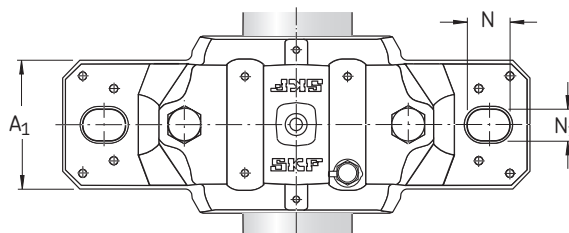
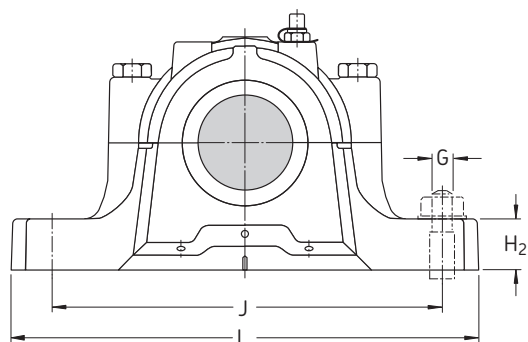

Shaft d_a	Bearing seat		Width across seals		Appropriate bearings and associated components					
	C_a	D_a	A_2	A_3	Self-aligning ball bearing Spherical roller bearing	Adapter sleeve	Locating rings 2 per housing	Self-aligning ball bearing Spherical roller bearing Sealed spherical roller bearing CARB toroidal roller bearing	Adapter sleeve	Locating rings 2 per housing
in/mm	mm		mm		-					
2 50,8	44	100	107	165	1211 EKTN9 -	HE 211 B -	FRB 11.5/100 -	2211 EKTN9 22211 EK BS2-2211-2CSK/VT143 C 2211 KTN9	HE 311 B HE 311 B HE 311 BE HE 311 BE	FRB 9.5/100 FRB 9.5/100 FRB 6.5/100 FRB 9.5/100
	51	120	122	170	1311 EKTN9 21311 EK	HE 311 HE 311	FRB 11/120 FRB 11/120	2311 K 22311 EK - -	HE 2311 B HE 2311 B - -	FRB 4/120 FRB 4/120 - -
2 1/8 53,975	48	110	117	175	1212 EKTN9 -	HS 212 -	FRB 13/110 -	2212 EKTN9 22212 EK BS2-2212-2CSK/VT143 C 2212 KTN9	HS 312 HS 312 HS 312 E HS 312 E	FRB 10/110 FRB 10/110 FRB 7/110 FRB 10/110
	56	130	127	175	1312 EKTN9 21312 EK	HS 312 HS 312	FRB 12.5/130 FRB 12.5/130	2312 K 22312 EK - -	HS 2312 HS 2312 - -	FRB 5/130 FRB 5/130 - -
2 3/16 55,563	51	120	122	180	1213 EKTN9 -	HA 213 -	FRB 14/120 -	2213 EKTN9 22213 EK BS2-2213-2CSK/VT143 C 2213 KTN9	HA 313 HA 313 HA 2313 E HA 313 E	FRB 10/120 FRB 10/120 FRB 6.5/120 FRB 10/120
	58	140	138	180	1313 EKTN9 21313 EK	HA 313 HA 313	FRB 12.5/140 FRB 12.5/140	2313 K 22313 EK - -	HA 2313 HA 2313 - -	FRB 5/140 FRB 5/140 - -
2 1/4 57,15	51	120	122	180	1213 EKTN9 -	HE 213 -	FRB 14/120 -	2213 EKTN9 22213 EK BS2-2213-2CSK/VT143 C 2213 KTN9	HE 313 HE 313 HE 2313 E HE 313 E	FRB 10/120 FRB 10/120 FRB 6.5/120 FRB 10/120
	58	140	138	180	1313 EKTN9 21313 EK	HE 313 HE 313	FRB 12.5/140 FRB 12.5/140	2313 K 22313 EK - -	HE 2313 HE 2313 - -	FRB 5/140 FRB 5/140 - -

SNL plummer block housings for bearings on an adapter sleeve, inch shafts

d_a 2 7/16 – 2 3/4 in

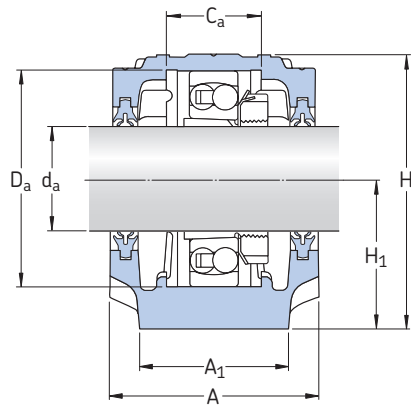

Four-lip seals, L/LA design¹⁾

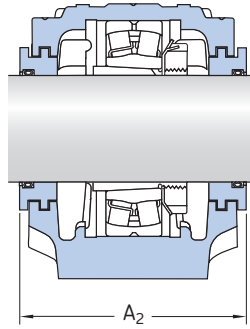

Labyrinth seals, SA/SE design

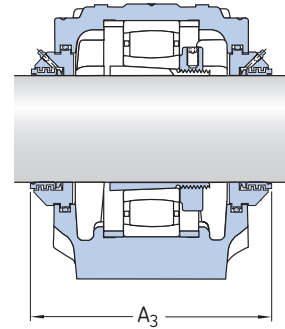

Taconite seals, NDA/NDE design

Shaft d_a	Housing Dimensions											Mass	Designations Housing	Seals	End cover	
	A	A ₁	H	H ₁	H ₂	J	L	N	N ₁	G	G					
in/mm	mm											in	kg	–		
2 7/16 61,913	115	80	155	80	30	230	280	24	18	16	5/8	7,00	SNL 515-612 SNL 515-612 SNL 515-612 SNL 515-612 SNL 515-612	TSN 515 LA TSN 515 AE TSN 515 CE TSN 515 SA TSN 515 NDA	ASNH 515-612 ASNH 515-612 ASNH 515-612 ASNH 515-612 ASNH 515-612	
	140	100	194	100	35	290	345	28	22	20	3/4	12,5	SNL 518-615 SNL 518-615 SNL 518-615 SNL 518-615	TSN 615 AE TSN 615 CE TSN 615 SA TSN 615 NDA	ASNH 518-615 ASNH 518-615 ASNH 518-615 ASNH 518-615	
2 1/2 63,5	115	80	155	80	30	230	280	24	18	16	5/8	7,00	SNL 515-612 SNL 515-612 SNL 515-612 SNL 515-612	TSN 515 A TSN 515 C TSN 515 SE TSN 515 NDE	ASNH 515-612 ASNH 515-612 ASNH 515-612 ASNH 515-612	
	140	100	194	100	35	290	345	28	22	20	3/4	12,5	SNL 518-615 SNL 518-615 SNL 518-615 SNL 518-615	TSN 615 A TSN 615 C TSN 615 SE TSN 615 NDE	ASNH 518-615 ASNH 518-615 ASNH 518-615 ASNH 518-615	
2 11/16 68,263	120	90	177	95	32	260	315	28	22	20	3/4	9,50	SNL 516-613 SNL 516-613 SNL 516-613 SNL 516-613	TSN 516 A TSN 516 C TSN 516 SA TSN 516 NDA	ASNH 516-613 ASNH 516-613 ASNH 516-613 ASNH 516-613	
	145	100	212	112	35	290	345	28	22	20	3/4	13,7	SNL 519-616 SNL 519-616 SNL 519-616 SNL 519-616	TSN 616 A TSN 616 C TSN 616 SA TSN 616 NDA	ASNH 519-616 ASNH 519-616 ASNH 519-616 ASNH 519-616	
2 3/4 69,85	120	90	177	95	32	260	315	28	22	20	3/4	9,50	SNL 516-613 SNL 516-613 SNL 516-613 SNL 516-613 SNL 516-613	TSN 516 L TSN 516 A TSN 516 C TSN 516 SE TSN 516 NDE	ASNH 516-613 ASNH 516-613 ASNH 516-613 ASNH 516-613 ASNH 516-613	
	145	100	212	112	35	290	345	28	22	20	3/4	13,7	SNL 519-616 SNL 519-616 SNL 519-616 SNL 519-616 SNL 519-616	TSN 616 L TSN 616 A TSN 616 C TSN 616 SE TSN 616 NDE	ASNH 519-616 ASNH 519-616 ASNH 519-616 ASNH 519-616 ASNH 519-616	

¹⁾ Dimension A remains the same also with A/AE and C/CE seal designs

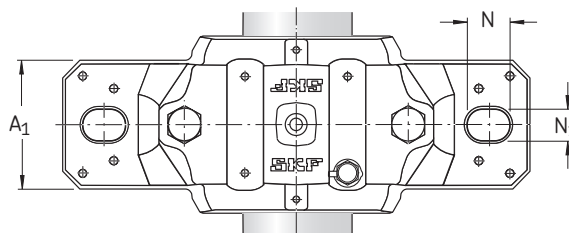
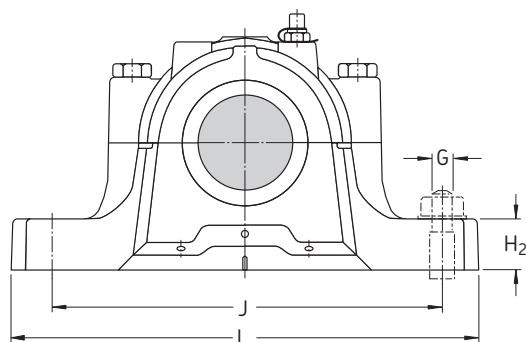

Shaft d_a	Bearing seat		Width across seals		Appropriate bearings and associated components					
	C_a	D_a	A_2	A_3	Self-aligning ball bearing Spherical roller bearing	Adapter sleeve	Locating rings 2 per housing	Self-aligning ball bearing Spherical roller bearing Sealed spherical roller bearing CARB toroidal roller bearing	Adapter sleeve	Locating rings 2 per housing
in/mm	mm		mm		-					
2 7/16 61,913	56	130	127	175	1215 K -	HA 215 -	FRB 15.5/130 -	2215 EKTN9 22215 EK BS2-2215-2CSK/VT143 C 2215 K	HA 315 HA 315 HA 315 E HA 315 E	FRB 12.5/130 FRB 12.5/130 FRB 9/130 FRB 12.5/130
	65	160	158	200	1315 KTN9 21315 EK	HA 315 HA 315	FRB 14/160 FRB 14/160	2315 K 22315 EK - C 2315 K	HA 2315 HA 2315 - HA 2315	FRB 5/160 FRB 5/160 - FRB 5/160
2 1/2 63,5	56	130	127	175	1215 K -	HE 215 -	FRB 15.5/130 -	2215 EKTN9 22215 EK BS2-2215-2CSK/VT143 C 2215 K	HE 315 HE 315 HE 315 E HE 315 E	FRB 12.5/130 FRB 12.5/130 FRB 9/130 FRB 12.5/130
	65	160	158	200	1315 K 21315 EK	HE 315 HE 315	FRB 14/160 FRB 14/160	2315 K 22315 EK - C 2315 K	HE 2315 HE 2315 - HE 2315	FRB 5/160 FRB 5/160 - FRB 5/160
2 11/16 68,263	58	140	138	205	1216 K -	HA 216 -	FRB 16/140 -	2216 EKTN9 22216 EK BS2-2216-2CSK/VT143 C 2216 K	HA 316 HA 316 HA 316 E HA 316 E	FRB 12.5/140 FRB 12.5/140 FRB 9/140 FRB 12.5/140
	68	170	163	205	1316 K 21316 EK	HA 316 HA 316	FRB 14.5/170 FRB 14.5/170	2316 K 22316 EK - C 2316 K	HA 2316 HA 2316 - HA 2316	FRB 5/170 FRB 5/170 - FRB 5/170
2 3/4 69,85	58	140	138	205	1216 K -	HE 216 -	FRB 16/140 -	2216 EKTN9 22216 EK BS2-2216-2CSK/VT143 C 2216 K	HE 316 HE 316 HE 316 E HE 316 E	FRB 12.5/140 FRB 12.5/140 FRB 9/140 FRB 12.5/140
	68	170	163	205	1316 K 21316 EK	HE 316 HE 316	FRB 14.5/170 FRB 14.5/170	2316 K 22316 EK - C 2316 K	HE 2316 HE 2316 - HE 2316	FRB 5/170 FRB 5/170 - FRB 5/170

SNL plummer block housings for bearings on an adapter sleeve, inch shafts

d_a 2 ¹⁵/₁₆ – 3 ¹/₄ in

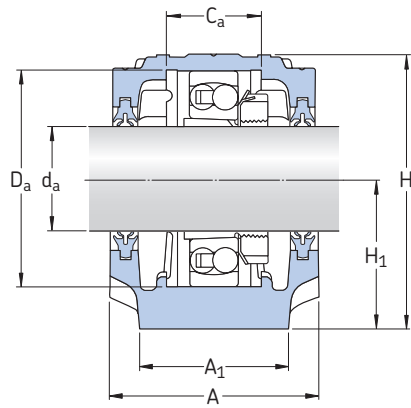

Four-lip seals, L design¹⁾

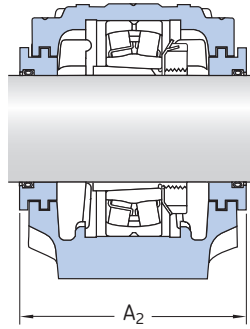

Labyrinth seals, SA/SE design

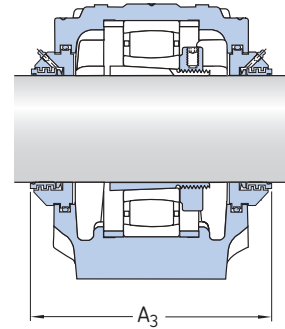

Taconite seals, NDA/NDE design

Shaft d_a	Housing Dimensions											Mass	Designations Housing	Seals	End cover	
	A	A ₁	H	H ₁	H ₂	J	L	N	N ₁	G	G					
in/mm	mm											in	kg	–		
2 ¹⁵ / ₁₆ 74,613	125	90	183	95	32	260	320	28	22	20	3/4	10,0	SNL 517 SNL 517 SNL 517 SNL 517 SNL 517	TSN 517 L TSN 517 A TSN 517 C TSNA 517 SA TSN 517 NDA	ASNH 517 ASNH 517 ASNH 517 ASNH 517 ASNH 517	
	160	110	218	112	40	320	380	32	26	24	7/8	17,6	SNL 520-617 SNL 520-617 SNL 520-617 SNL 520-617 SNL 520-617	TSN 617 L TSN 617 A TSN 617 C TSN 617 SA TSN 617 NDA	ASNH 520-617 ASNH 520-617 ASNH 520-617 ASNH 520-617 ASNH 520-617	
3 76,2	125	90	183	95	32	260	320	28	22	20	3/4	10,0	SNL 517 SNL 517 SNL 517 SNL 517 SNL 517	TSN 517 L TSN 517 A TSN 517 C TSN 517 SE TSN 517 NDE	ASNH 517 ASNH 517 ASNH 517 ASNH 517 ASNH 517	
	160	110	218	112	40	320	380	32	26	24	7/8	17,6	SNL 520-617 SNL 520-617 SNL 520-617 SNL 520-617 SNL 520-617	TSN 617 L TSN 617 A TSN 617 C TSN 617 SE TSN 617 NDE	ASNH 520-617 ASNH 520-617 ASNH 520-617 ASNH 520-617 ASNH 520-617	
3 ³ / ₁₆ 80,963	140	100	194	100	35	290	345	28	22	20	3/4	12,5	SNL 518-615 SNL 518-615 SNL 518-615 SNL 518-615 SNL 518-615	TSN 518 L TSN 518 A TSN 518 CE TSN 518 SA TSN 518 NDA	ASNH 518-615 ASNH 518-615 ASNH 518-615 ASNH 518-615 ASNH 518-615	
	140	100	194	100	35	290	345	28	22	20	3/4	12,5	SNL 518-615 SNL 518-615 SNL 518-615 SNL 518-615	TSN 518 A TSN 518 CE TSN 518 SE TSN 518 NDE	ASNH 518-615 ASNH 518-615 ASNH 518-615 ASNH 518-615	
3 ¹ / ₄ 82,55	140	100	194	100	35	290	345	28	22	20	3/4	12,5	SNL 518-615 SNL 518-615 SNL 518-615 SNL 518-615	TSN 518 A TSN 518 CE TSN 518 SE TSN 518 NDE	ASNH 518-615 ASNH 518-615 ASNH 518-615 ASNH 518-615	
	175	120	242	125	45	350	410	32	26	24	7/8	22,0	SNL 522-619 SNL 522-619 SNL 522-619 SNL 522-619	TSN 619 A TSN 619 C TSN 619 SE TSN 619 NDE	ASNH 522-619 ASNH 522-619 ASNH 522-619 ASNH 522-619	

¹⁾ Dimension A remains the same also with A and C/CE seal designs

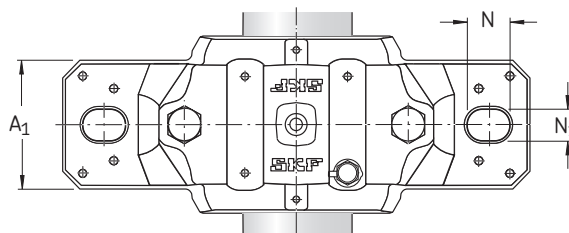
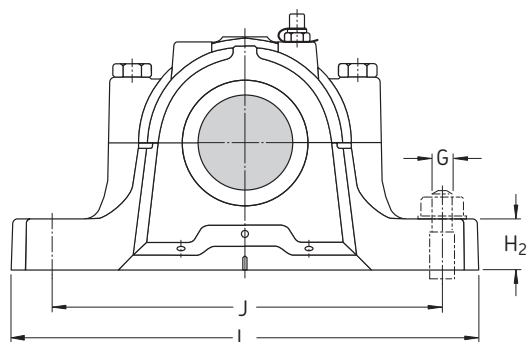

Shaft d_a	Bearing seat		Width across seals		Appropriate bearings and associated components					
	C_a	D_a	A_2	A_3	Self-aligning ball bearing Spherical roller bearing	Adapter sleeve	Locating rings 2 per housing	Self-aligning ball bearing Spherical roller bearing Sealed spherical roller bearing CARB toroidal roller bearing	Adapter sleeve	Locating rings 2 per housing
in/mm	mm		mm		-					
2^{15/16} 74,613	61	150	143	210	1217 K -	HA 217 -	FRB 16.5/150 -	2217 K 22217 EK BS2-2217-2CSK/VT143 C 2217 K	HA 317 HA 317 HA 317 E HA 317 E	FRB 12.5/150 FRB 12.5/150 FRB 8.5/150 FRB 12.5/150
	70	180	178	220	1317 K 21317 EK	HA 317 HA 317	FRB 14.5/180 FRB 14.5/180	2317 K 22317 EK - C 2317 K	HA 2317 HA 2317 - HA 2317	FRB 5/180 FRB 5/180 - FRB 5/180
3 76,2	61	150	143	210	1217 K -	HE 217 -	FRB 16.5/150 -	2217 K 22217 EK BS2-2217-2CSK/VT143 C 2217 K	HE 317 HE 317 HE 317 E HE 317 E	FRB 12.5/150 FRB 12.5/150 FRB 8.5/150 FRB 12.5/150
	70	180	178	220	1317 K 21317 EK	H 317 H 317	FRB 14.5/180 FRB 14.5/180	2317 K 22317 EK - C 2317 K	HE 2317 HE 2317 - HE 2317	FRB 5/180 FRB 5/180 - FRB 5/180
3^{3/16} 80,963	65	160	158	225	1218 K 23218 CCK/W33	HA 218 HA 2318	FRB 17.5/160 FRB 6.25/160	2218 K 22218 EK BS2-2218-2CSK/VT143 C 2218 K	HA 318 HA 318 HA 2318 E HA 318 E	FRB 12.5/160 FRB 12.5/160 FRB 8.5/160 FRB 12.5/160
	65	160	158	225	1218 K 23218 CCK/W33	HE 218 HE 2318	FRB 17,5/160 FRB 6.25/160	2218 K 22218 EK BS2-2218-2CSK/VT143 C 2218 K	HE 318 HE 318 HE 2318 E HE 318 E	FRB 12.5/160 FRB 12,5/160 FRB 8.5/160 FRB 12.5/160
3^{1/4} 82,55	80	200	191	235	1319 K 21319 EK	HE 319 HE 319	FRB 17.5/200 FRB 17.5/200	2319 KM 22319 EK - C 2319 K	HE 2319 HE 2319 - HE 2319	FRB 6.5/200 FRB 6.5/200 - FRB 6.5/200

SNL plummer block housings for bearings on an adapter sleeve, inch shafts

d_a 3 7/16 – 4 1/4 in

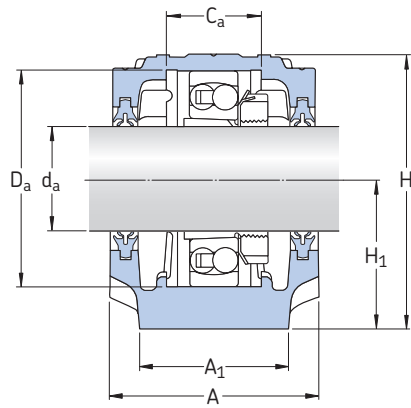

Four-lip seals, L design¹⁾

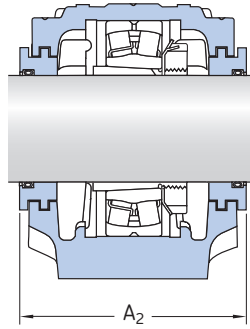

Labyrinth seals, SA/SE design

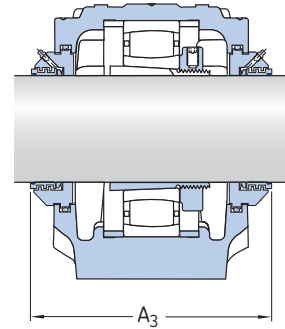

Taconite seals, NDA/NDE design

Shaft d_a	Housing Dimensions											Mass	Designations Housing	Seals	End cover	
	A	A ₁	H	H ₁	H ₂	J	L	N	N ₁	G	G					
in/mm	mm											in	kg	–		
3 7/16 87,313	160	110	218	112	40	320	380	32	26	24	7/8	17,6	SNL 520-617 SNL 520-617 SNL 520-617 SNL 520-617	TSN 520 A TSN 520 C TSN 520 SA TSN 520 NDA	ASNH 520-617 ASNH 520-617 ASNH 520-617 ASNH 520-617	
	185	120	271	140	45	350	410	32	26	24	7/8	26,2	SNL 524-620 SNL 524-620 SNL 524-620 SNL 524-620	TSN 620 A TSN 620 C TSN 620 SA TSN 620 NDA	ASNH 524-620 ASNH 524-620 ASNH 524-620 ASNH 524-620	
3 1/2 88,9	160	110	218	112	40	320	380	32	26	24	7/8	17,6	SNL 520-617 SNL 520-617 SNL 520-617 SNL 520-617	TSN 520 A TSN 520 C TSN 520 SE TSN 520 NDE	ASNH 520-617 ASNH 520-617 ASNH 520-617 ASNH 520-617	
	185	120	271	140	45	350	410	32	26	24	7/8	26,2	SNL 524-620 SNL 524-620 SNL 524-620 SNL 524-620	TSN 620 A TSN 620 C TSN 620 SE TSN 620 NDE	ASNH 524-620 ASNH 524-620 ASNH 524-620 ASNH 524-620	
3 15/16 100,012	175	120	242	125	45	350	410	32	26	24	7/8	22,0	SNL 522-619 SNL 522-619 SNL 522-619 SNL 522-619 SNL 522-619	TSN 522 L TSN 522 A TSN 522 C TSN 522 SA TSN 522 NDA	ASNH 522-619 ASNH 522-619 ASNH 522-619 ASNH 522-619 ASNH 522-619	
	175	120	242	125	45	350	410	32	26	24	7/8	22,0	SNL 522-619 SNL 522-619 SNL 522-619 SNL 522-619 SNL 522-619	TSN 522 L TSN 522 A TSN 522 C TSN 522 SE TSN 522 NDE	ASNH 522-619 ASNH 522-619 ASNH 522-619 ASNH 522-619 ASNH 522-619	
4 101,6	175	120	242	125	45	350	410	32	26	24	7/8	22,0	SNL 522-619 SNL 522-619 SNL 522-619 SNL 522-619 SNL 522-619	TSN 522 L TSN 522 A TSN 522 C TSN 522 SE TSN 522 NDE	ASNH 522-619 ASNH 522-619 ASNH 522-619 ASNH 522-619 ASNH 522-619	
	185	120	271	140	45	350	410	32	26	24	7/8	26,2	SNL 524-620 SNL 524-620 SNL 524-620 SNL 524-620	TSN 524 A TSN 524 CE TSN 524 SA TSN 524 NDA	ASNH 524-620 ASNH 524-620 ASNH 524-620 ASNH 524-620	
4 3/16 106,363	185	120	271	140	45	350	410	32	26	24	7/8	26,2	SNL 524-620 SNL 524-620 SNL 524-620 SNL 524-620	TSN 524 A TSN 524 CE TSN 524 SA TSN 524 NDA	ASNH 524-620 ASNH 524-620 ASNH 524-620 ASNH 524-620	
	185	120	271	140	45	350	410	32	26	24	7/8	26,2	SNL 524-620 SNL 524-620 SNL 524-620 SNL 524-620	TSN 524 A TSN 524 C TSN 524 SE TSN 524 NDE	ASNH 524-620 ASNH 524-620 ASNH 524-620 ASNH 524-620	
4 1/4 107,95	185	120	271	140	45	350	410	32	26	24	7/8	26,2	SNL 524-620 SNL 524-620 SNL 524-620 SNL 524-620	TSN 524 A TSN 524 C TSN 524 SE TSN 524 NDE	ASNH 524-620 ASNH 524-620 ASNH 524-620 ASNH 524-620	
	185	120	271	140	45	350	410	32	26	24	7/8	26,2	SNL 524-620 SNL 524-620 SNL 524-620 SNL 524-620	TSN 524 A TSN 524 C TSN 524 SE TSN 524 NDE	ASNH 524-620 ASNH 524-620 ASNH 524-620 ASNH 524-620	

¹⁾ Dimension A remains the same also with A and C/CE seal designs

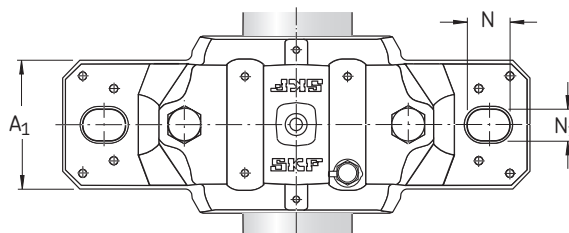
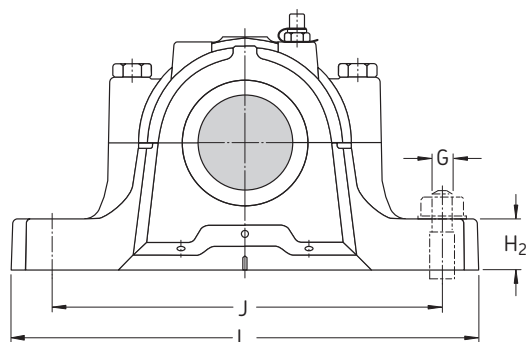

Shaft d_a	Bearing seat D_a		Width across seals A_2 A_3		Appropriate bearings and associated components					
	C_a	D_a	A_2	A_3	Self-aligning ball bearing Spherical roller bearing CARB toroidal roller bearing	Adapter sleeve	Locating rings 2 per housing	Self-aligning ball bearing Spherical roller bearing Sealed spherical roller bearing CARB toroidal roller bearing	Adapter sleeve	Locating rings 2 per housing
in/mm	mm		mm		-					
3 7/16 87,313	70	180	178	230	1220 K 23220 CCK/W33 -	HA 220 HA 2320 -	FRB 18/180 FRB 4.85/180 -	2220 KM 22220 EK BS2-2220-2CS5K/VT143 C 2220 K	HA 320 HA 320 HA 2320 E HA 320 E	FRB 12/180 FRB 12/180 FRB 7.5/180 FRB 12/180
	86	215	199	240	1320 K 21320 EK -	HA 320 HA 320 -	FRB 19.5/215 FRB 19.5/215 -	2320 KM 22320 EK C2320 K	HA 2320 HA 2320 HA 2320	FRB 6.5/215 FRB 6.5/215 FRB 6.5/215
3 1/2 88,9	70	180	178	230	1220 K 23220 CCK/W33 -	HE 220 HE 2320 -	FRB 18/180 FRB 4.85/180 -	2220 KM 22220 EK BS2-2220-2CS5K/VT143 C 2220 K	HE 320 HE 320 HE 2320 E HE 320 E	FRB 12/180 FRB 12/180 FRB 7.5/180 FRB 12/180
	86	215	199	240	1320 EK 21320 EK -	HE 320 HE 320 -	FRB 19.5/215 FRB 19.5/215 -	2320 KM 22320 EK C 2320 K	HE 2320 HE 2320 HE 2320	FRB 6.5/215 FRB 6.5/215 FRB 6.5/215
3 15/16 100,012	80	200	191	250	1222 K 23222 CCK/W33 -	H 222 H 2322 -	FRB 21/200 FRB 5.1/200 -	2222 KM 22222 EK BS2-2222-2CS5K/VT143 C 2222 K	H 322 H 322 H 2322 E H 322 E	FRB 13.5/200 FRB 13.5/200 FRB 8.5/200 FRB 13.5/200
	86	200	191	250	1222 K 23222 CCK/W33 -	HE 222 HE 2322 -	FRB 21/200 FRB 5.1/200 -	2222 KM 22222 EK BS2-2222-2CS5K/VT143 C 2222 K	HE 322 HE 322 HE 2322 E HE 322 E	FRB 13.5/200 FRB 13.5/200 FRB 8.5/200 FRB 13.5/200
4 101,6	80	200	191	250	1222 K 23222 CCK/W33 -	HE 222 HE 2322 -	FRB 21/200 FRB 5.1/200 -	2222 KM 22222 EK BS2-2222-2CS5K/VT143 C 2222 K	HE 322 HE 322 HE 2322 E HE 322 E	FRB 13.5/200 FRB 13.5/200 FRB 8.5/200 FRB 13.5/200
	86	215	199	260	1224 K 23224 CCK/W33 C 3224 K	HA 3024 HA 2324 HA 2324 L	FRB 22/215 FRB 5/215 FRB 5/215	- 22224 EK BS2-2224-2CS5K/VT143 -	HA 3124 HA 2324 E HA 2324 E	FRB 14/215 FRB 8.5/215 FRB 8.5/215
4 1/4 107,95	86	215	199	260	1224 KM 23224 CCK/W33 C 3224 K	HE 3024 HE 2324 HE 2324 L	FRB 22/215 FRB 5/215 FRB 5/215	- 22224 EK BS2-2224-2CS5K/VT143 C 2224 K¹⁾	HE 3124 HE 2324 E HE 3124 L	FRB 14/215 FRB 8.5/215 FRB 14/215

¹⁾ Check with SKF for availability

SNL plummer block housings for bearings on an adapter sleeve, inch shafts

d_a 4 7/16 – 5 1/2 in

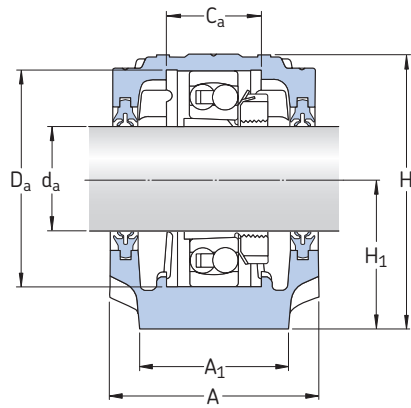

Four-lip seals, L design¹⁾

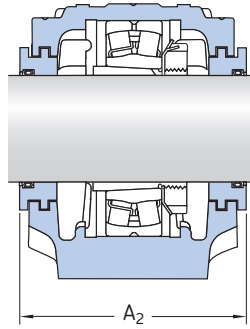

Labyrinth seals, SA/SE design

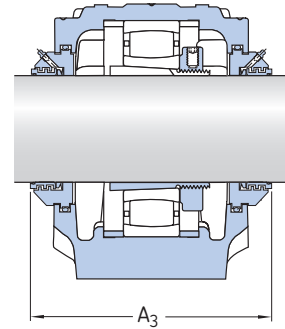

Taconite seals, NDA/NDE design

Shaft d_a	Housing Dimensions											Mass	Designations Housing	Seals	End cover	
	A	A ₁	H	H ₁	H ₂	J	L	N	N ₁	G	G					
in/mm	mm											in	kg	–		
4 7/16 112,713	190	130	290	150	50	380	445	35	28	24	1	33,0	SNL 526 SNL 526 SNL 526 SNL 526	TSN 526 A TSN 526 C TSN 526 SA TSN 526 NDA	ASNH 526 ASNH 526 ASNH 526 ASNH 526	
4 1/2 114,3	190	130	290	150	50	380	445	35	28	24	1	33,0	SNL 526 SNL 526 SNL 526 SNL 526 SNL 526	TSN 526 L TSN 526 A TSN 526 C TSN 526 SE TSN 526 NDE	ASNH 526 ASNH 526 ASNH 526 ASNH 526 ASNH 526	
4 15/16 125,413	205	150	302	150	50	420	500	42	35	30	1 1/4	40,0	SNL 528 SNL 528 SNL 528 SNL 528 SNL 528	TSN 528 L TSN 528 A TSN 528 C TSN 528 SA TSN 528 NDA	ASNH 528 ASNH 528 ASNH 528 ASNH 528 ASNH 528	
5 127	205	150	302	150	50	420	500	42	35	30	1 1/4	40,0	SNL 528 SNL 528 SNL 528 SNL 528	TSN 528 A TSN 528 C TSN 528 SE TSN 528 NDE	ASNH 528 ASNH 528 ASNH 528 ASNH 528	
5 3/16 131,763	220	160	323	160	60	450	530	42	35	30	1 1/4	49,0	SNL 530 SNL 530 SNL 530 SNL 530	TSN 530 A TSN 530 C TSN 530 SA TSN 530 NDA	ASNH 530 ASNH 530 ASNH 530 ASNH 530	
5 1/4 133,35	220	160	323	160	60	450	530	42	35	30	1 1/4	49,0	SNL 530 SNL 530 SNL 530 SNL 530	TSN 530 A TSN 530 C TSN 530 SE TSN 530 NDE	ASNH 530 ASNH 530 ASNH 530 ASNH 530	
5 7/16 138,113	235	160	344	170	60	470	550	42	35	30	1 1/4	55,0	SNL 532 SNL 532 SNL 532 SNL 532	TSN 532 A TSN 532 C TSN 532 SA TSN 532 NDA	ASNH 532 ASNH 532 ASNH 532 ASNH 532	
5 1/2 139,7	235	160	344	170	60	470	550	42	35	30	1 1/4	55,0	SNL 532 SNL 532 SNL 532 SNL 532 SNL 532	TSN 532 L TSN 532 A TSN 532 C TSN 532 SE TSN 532 NDE	ASNH 532 ASNH 532 ASNH 532 ASNH 532 ASNH 532	

¹⁾ Dimension A remains the same also with A and C/CE seal designs

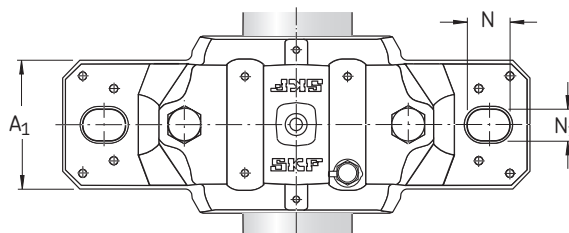
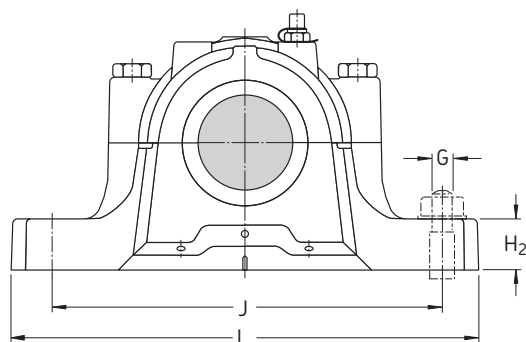

Shaft d_a	Bearing seat		Width across seals		Appropriate bearings and associated components					
	C_a	D_a	A_2	A_3	Spherical roller bearing Sealed spherical roller bearing CARB toroidal roller bearing	Adapter sleeve	Locating rings 2 per housing	Spherical roller bearing Sealed spherical roller bearing CARB toroidal roller bearing	Adapter sleeve	Locating rings 2 per housing
in/mm	mm		mm		-					
4 7/16 112,713	90	230	208	265	23226 CCK/W33 23226-2CS5K/VT143 -	HA 2326 HA 2326 -	FRB 5/230 FRB 5/230 -	22226 EK BS2-2226-2CS5K/VT143 C 2226 K	HA 3126 HA 2326 E HA 3126 L	FRB 13/230 FRB 7.5/230 FRB 13/230
4 1/2 114,3	90	230	208	265	23226 CCK/W33 23226-2CS5K/VT143 -	HE 2326 HE 2326 -	FRB 5/230 FRB 5/230 -	22226 EK BS2-2226-2CS5K/VT143 C 2226 K	HE 3126 HE 2326 E HE 3126 L	FRB 13/230 FRB 7.5/230 FRB 13/230
4 15/16 125,413	98	250	223	285	23228 CCK/W33 23228-2CS5K/VT143 -	HA 2328 HA 2328 -	FRB 5/250 FRB 5/250 -	22228 CCK/W33 22228-2CS5K/VT143 C 2228 K	HA 3128 HA 3128 L HA 3128 L	FRB 15/250 FRB 15/250 FRB 15/250
5 127	98	250	223	285	23228 CCK/W33 23228-2CS5K/VT143 -	HE 2328 HE 2328 -	FRB 5/250 FRB 5/250 -	22228 CCK/W33 22228-2CS5K/VT143 C 2228 K	HE 3128 HE 3128 L HE 3128 L	FRB 15/250 FRB 15/250 FRB 15/250
5 3/16 131,763	106	270	241	295	23230 CCK/W33 23230-2CS5K/VT143 -	HA 2330 HA 2330 -	FRB 5/270 FRB 5/270 -	22230 CCK/W33 22230-2CS5K/VT143 C 2230 K	HA 3130 HA 3130 HA 3130 L	FRB 16.5/270 FRB 16.5/270 FRB 16.5/270
5 1/4 133,35	106	270	241	295	23230 CCK/W33 23230-2CS5K/VT143 -	HE 2330 HE 2330 -	FRB 5/270 FRB 5/270 -	22230 CCK/W33 22230-2CS5K/VT143 C 2230 K	HE 3130 HE 3130 HE 3130 L	FRB 16.5/270 FRB 16.5/270 FRB 16.5/270
5 7/16 138,113	114	290	254	315	23232 CCK/W33 - C 3232 K	HA 2332 - HA 2332 L	FRB 5/290 - FRB 5/290	22232 CCK/W33 22232-2CS5K/VT143 -	HA 3132 HA 3132 -	FRB 17/290 FRB 17/290 -
5 1/2 139,7	114	290	254	315	23232 CCK/W33 - C 3232 K	HE 2332 - HE 2332 L	FRB 5/290 - FRB 5/290	22232 CCK/W33 22232-2CS5K/VT143 -	HE 3132 HE 3132 -	FRB 17/290 FRB 17/290 -

SNL plummer block housings for bearings with a cylindrical bore

d_a 25 – 40 mm

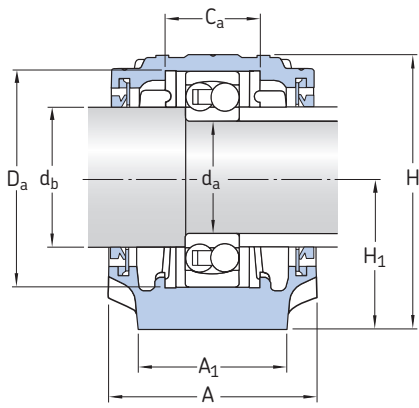

V-ring seals, A design

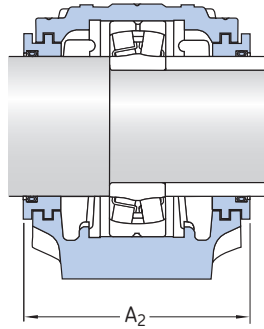

Labyrinth seals, S design

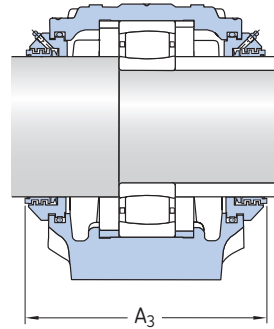

Taconite seals, ND design

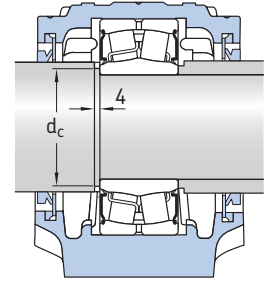

Housing with sealed spherical roller bearing

Shaft d_a	Housing Dimensions											Mass kg	Designations Housing	Seals	End cover
	A	A ₁	H	H ₁	H ₂	J	L	N	N ₁	G					
mm	mm											kg	–		
25	67	46	74	40	19	130	165	20	15	12	1,40	SNL 505 SNL 205 SNL 205	2 FS 170 TSN 205 S TSN 205 ND	ASNH 505 ASNH 506-605 ASNH 506-605	
	77	52	89	50	22	150	185	20	15	12	1,90	SNL 206-305 SNL 206-305 SNL 206-305	TSN 305 A TSN 305 S TSN 305 ND	ASNH 507-606 ASNH 507-606 ASNH 507-606	
30	77	52	89	50	22	150	185	20	15	12	1,90	SNL 206-305 SNL 506-605 SNL 206-305 SNL 206-305	TSN 206 A 2 FS 170 TSN 206 S TSN 206 ND	ASNH 507-606 ASNH 506-605 ASNH 507-606 ASNH 507-606	
	82	52	93	50	22	150	185	20	15	12	2,20	SNL 507-606 SNL 507-606 SNL 507-606	TSN 306 A TSN 306 S TSN 306 ND	ASNH 507-606 ASNH 507-606 ASNH 507-606	
35	82	52	93	50	22	150	185	20	15	12	2,10	SNL 207 SNL 507-606 SNL 207 SNL 207	TSN 207 A 4 FS 170 TSN 207 S TSN 207 ND	ASNH 509 ASNH 507-606 ASNH 509 ASNH 509	
	85	60	108	60	25	170	205	20	15	12	2,75	SNL 208-307 SNL 208-307 SNL 208-307	TSN 307 A TSN 307 S TSN 307 ND	ASNH 510-608 ASNH 510-608 ASNH 510-608	
40	85	60	108	60	25	170	205	20	15	12	2,75	SNL 208-307 SNL 508-607 SNL 208-307 SNL 208-307	TSN 208 A 4 FS 170 TSN 208 S TSN 208 ND	ASNH 510-608 ASNH 508-607 ASNH 510-608 ASNH 510-608	
	90	60	113	60	25	170	205	20	15	12	3,20	SNL 510-608 SNL 510-608 SNL 510-608	TSN 308 A TSN 308 S TSN 308 ND	ASNH 510-608 ASNH 510-608 ASNH 510-608	

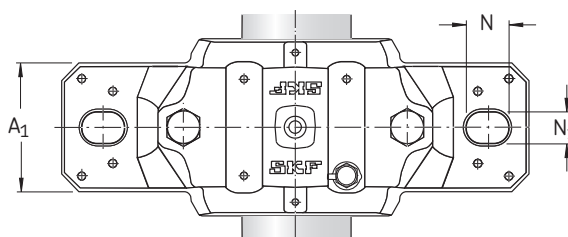
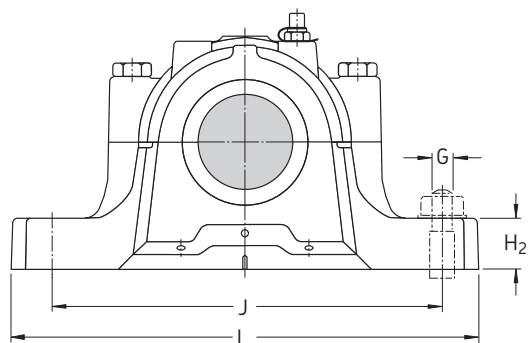

Shaft				Bearing seat		Width across seals		Appropriate bearings and associated components			
d_a	d_b	$d_c^{1)}$ min	$d_c^{1)}$ max	C_a	D_a	A_2	A_3	Self-aligning ball bearing	Locating rings 2 per housing	Self-aligning roller bearing	Locating rings 2 per housing
								Spherical roller bearing		Sealed spherical roller bearing	
								Spherical roller bearing		CARB toroidal roller bearing	
mm				mm		mm		-			
25	30	-	-	25	52	90	140	1205 ETN9 -	FRB 5/52	2205 ETN9 22205 E BS2-2205-2CS/VT143 C 2205 TN9³⁾	FRB 3.5/52 FRB 3.5/52 FRB 1/52 FRB 3.5/52
	30	-	-	32	62	89	140	1305 ETN9 21305 CC	FRB 7.5/62 FRB 7.5/62	2305 ETN9 - - -	FRB 4/62 - - -
30	35	-	-	32	62	89	150	1206 ETN9 -	FRB 8/62 -	2206 ETN9 22206 E BS2-2206-2CS/VT143 C 2206 TN9	FRB 6/62 FRB 6/62 FRB 3.5/62 FRB 6/62
	35	-	-	34	72	94	155	1306 ETN9 21306 CC	FRB 7.5/72 FRB 7.5/72	2306 - - -	FRB 3.5/72 - - -
35	45	42	43	34	72	96	160	1207 E -	FRB 8.5/72 -	2207 ETN9 22207 E BS2-2207-2CS/VT143²⁾ C 2207 TN9	FRB 5.5/72 FRB 5.5/72 FRB 3/72 FRB 5.5/72
	45	-	-	39	80	99	145	1307 ETN9 21307 CC	FRB 9/80 FRB 9/80	2307 ETN9 - - -	FRB 4/80 - - -
40	50	47	47	39	80	99	160	1208 ETN9 -	FRB 10.5/80 -	2208 ETN9 22208 E BS2-2208-2CS/VT143²⁾ C 2208 TN9	FRB 8/80 FRB 8/80 FRB 5.5/80 FRB 8/80
	50	-	-	41	90	102	167	1308 ETN9 21308 E	FRB 9/90 FRB 9/90	2308 ETN9 22308 E BS2-2308-2CS/VT143 -	FRB 4/90 FRB 4/90 FRB 1.5/90 -

¹⁾ Valid for some sealed spherical roller bearings only

²⁾ The shaft must be modified according to d_c values for the bearing

³⁾ Check with SKF for availability

SNL plummer block housings for bearings with a cylindrical bore

d_a 45 – 60 mm

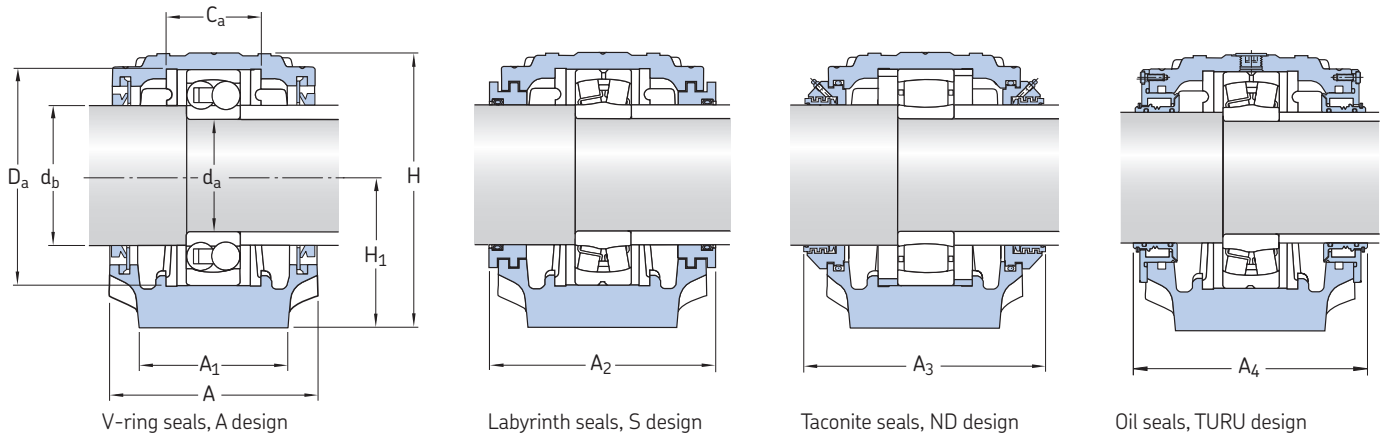

Shaft d_a	Housing Dimensions											Mass kg	Designations		
	A	A_1	H	H_1	H_2	J	L	N	N_1	G	Housing		Seals	End cover	
mm	mm												-		
45	85	60	109	60	25	170	205	20	15	12	2,75	SNL 209 SNL 509 SNL 209 SNL 209	TSN 209 A 4 FS 170 TSN 209 S TSN 209 ND	ASNH 511-609 ASNH 509 ASNH 511-609 ASNH 511-609	
	95	70	128	70	28	210	255	24	18	16	4,40	SNL 511-609 SNL 511-609 SNL 511-609	TSN 309 A TSN 309 S TSN 309 ND	ASNH 511-609 ASNH 511-609 ASNH 511-609	
50	90	60	113	60	25	170	205	20	15	12	3,00	SNL 210 SNL 510-608 SNL 210 SNL 210	TSN 210 A 4 FS 170 TSN 210 S TSN 210 ND	ASNH 512-610 ASNH 510-608 ASNH 512-610 ASNH 512-610	
	105	70	134	70	30	210	255	24	18	16	5,10	SNL 512-610 SNL 512-610 SNL 512-610	TSN 310 A TSN 310 S TSN 310 ND	ASNH 512-610 ASNH 512-610 ASNH 512-610	
55	95	70	128	70	28	210	255	24	18	16	4,20	SNL 211 SNL 511-609 SNL 211 SNL 211	TSN 211 A 4 FS 170 TSN 211 S TSN 211 ND	ASNH 513-611 ASNH 511-609 ASNH 513-611 ASNH 513-611	
	110	80	150	80	30	230	275	24	18	16	6,50	SNL 513-611 SNL 513-611 SNL 513-611	TSN 311 A TSN 311 S TSN 311 ND	ASNH 513-611 ASNH 513-611 ASNH 513-611	
60	105	70	134	70	30	210	255	24	18	16	4,75	SNL 212 SNL 512-610 SNL 212 SNL 212	TSN 212 A 4 FS 170 TSN 212 S TSN 212 ND	ASNH 515-612 ASNH 512-610 ASNH 515-612 ASNH 515-612	
	115	80	156	80	30	230	280	24	18	16	7,00	SNL 515-612 SNL 515-612 SNL 515-612 SNL 312 TURU	TSN 312 A TSN 312 S TSN 312 ND included	ASNH 515-612 ASNH 515-612 ASNH 515-612 ASNH 518-615 R	

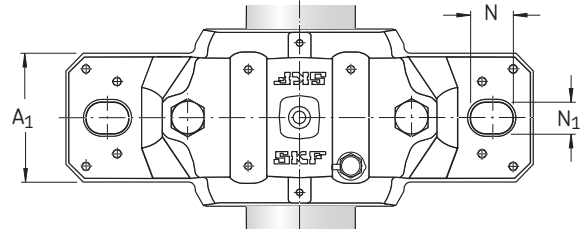
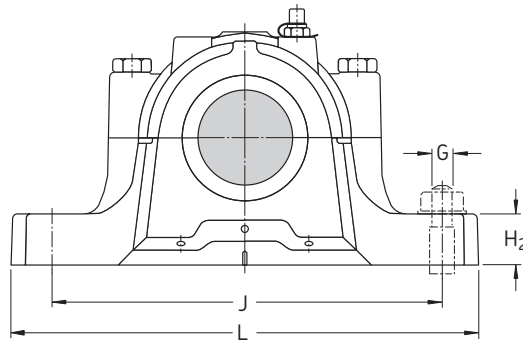
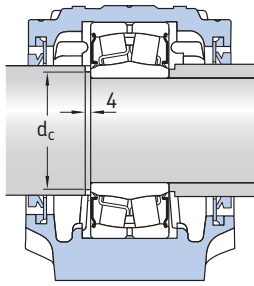

Housing with a sealed spherical roller bearing

Shaft				Bearing seat		Width across seals			Appropriate bearings and associated components					
d_a	d_b	$d_c^{1)}$ min	$d_c^{1)}$ max	C_a	D_a	A_2	A_3	A_4	Self-aligning ball bearing	Locating rings 2 per housing	Self-aligning ball bearing	Spherical roller bearing	Sealed spherical roller bearing	Locating rings 2 per housing
mm	mm	mm	mm	mm	mm	mm	mm	mm	–	–	–	–	–	–
45	55	52	53	30	85	97	160	–	1209 ETN9 –	FRB 5.5/85 –	2209 ETN9 22209 E BS2-2209-2CS/VT143 ²⁾ C 2209 TN9	FRB 3.5/85 FRB 3.5/85 FRB 1/85 FRB 3.5/85		
	55	–	–	44	100	107	172	–	1309 ETN9 21309 E	FRB 9.5/100 FRB 9.5/100	2309 ETN9 22309 E – –	FRB 4/100 FRB 4/100 – –		
50	60	57	58	41	90	102	165	–	1210 ETN9 –	FRB 10.5/90 –	2210 ETN9 22210 E BS2-2210-2CS/VT143 ²⁾ C 2210 TN9	FRB 9/90 FRB 9/90 FRB 6.5/90 FRB 9/90		
	60	–	–	48	110	117	180	–	1310 ETN9 21310 E	FRB 10.5/110 FRB 10.5/110	2310 22310 E – –	FRB 4/110 FRB 4/110 – –		
55	65	64	64	44	100	107	170	–	1211 ETN9 –	FRB 11.5/100 –	2211 ETN9 22211 E BS2-2211-2CS/VT143 ²⁾ C 2211 TN9	FRB 9.5/100 FRB 9.5/100 FRB 6.5/100 FRB 9.5/100		
	65	–	–	51	120	122	185	–	1311 ETN9 21311 E	FRB 11/120 FRB 11/120	2311 22311 E BS2-2311-2CS/VT143 –	FRB 4/120 FRB 4/120 FRB 1/120 –		
60	70	69	69	48	110	117	185	–	1212 ETN9 –	FRB 13/110 –	2212 ETN9 22212 E BS2-2212-2CS/VT143 ²⁾ C 2212 TN9	FRB 10/110 FRB 10/110 FRB 7/110 FRB 10/110		
	70	–	–	56	130	127	197	134	1312 ETN9 21312 E	FRB 12.5/130 FRB 12.5/130	2312 22312 E – –	FRB 5/130 FRB 5/130 – –		

¹⁾ Valid for some sealed spherical roller bearings only
²⁾ The shaft must be modified according to d_c values for the bearing

SNL plummer block housings for bearings with a cylindrical bore

d_a 65 – 80 mm

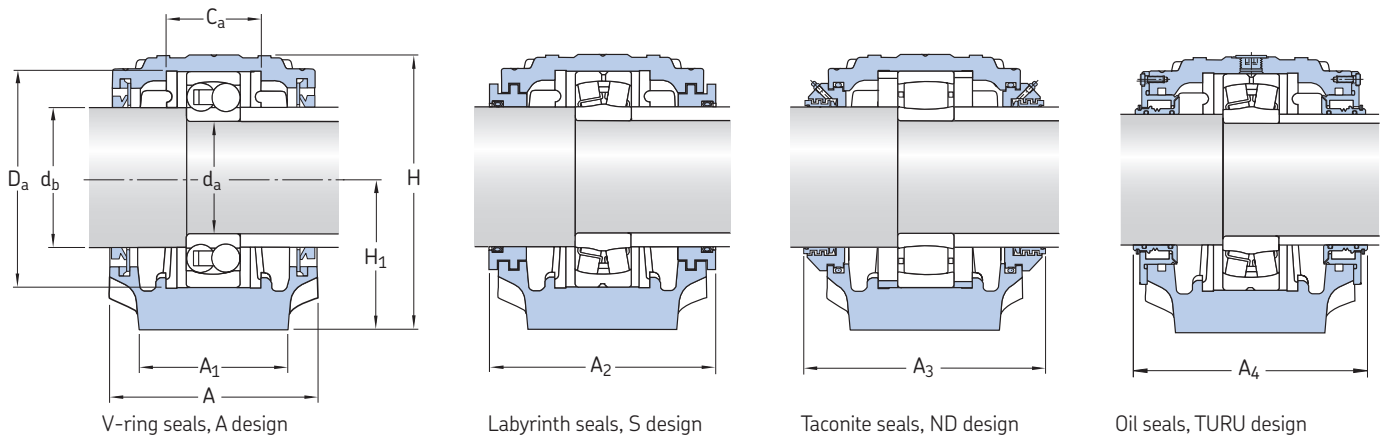

Shaft d_a	Housing Dimensions										Mass	Designations		
	A	A ₁	H	H ₁	H ₂	J	L	N	N ₁	G		Housing	Seals	End cover
mm	mm										kg	-		
65	110	80	149	80	30	230	275	24	18	16	6,10	SNL 213 SNL 513-611 SNL 213 SNL 213	TSN 213 A 4 FS 170 TSN 213 S TSN 213 ND	ASNH 516-613 ASNH 513-611 ASNH 516-613 ASNH 516-613
	120	90	177	95	32	260	315	28	22	20	9,50	SNL 516-613 SNL 516-613 SNL 516-613 SNL 313 TURU	TSN 313 A TSN 313 S TSN 313 ND included	ASNH 516-613 ASNH 516-613 ASNH 516-613 ASNH 216 R
70	125	90	183	95	32	260	320	28	22	20	10,0	SNL 517 SNL 517 SNL 517 SNL 314 TURU	TSN 314 A TSN 314 S TSN 314 ND included	ASNH 517 ASNH 517 ASNH 517 ASNH 217 R
75	115	80	155	80	30	230	280	24	18	16	6,60	SNL 215 SNL 515-612 SNL 215 SNL 215	TSN 215 A 4 FS 170 TSN 215 S TSN 215 ND	ASNH 518-615 ASNH 515-612 ASNH 518-615 ASNH 518-615
	140	100	194	100	35	290	345	28	22	20	12,5	SNL 518-615 SNL 518-615 SNL 518-615 SNL 315 TURU	TSN 315 A TSN 315 S TSN 315 ND included	ASNH 518-615 ASNH 518-615 ASNH 518-615 ASNH 218 R
80	120	90	177	95	32	260	315	28	22	20	9,00	SNL 216 SNL 516-613 SNL 216 SNL 216	TSN 216 A 4 FS 170 TSN 216 S TSN 216 ND	ASNH 216 ASNH 516-613 ASNH 216 ASNH 216
	145	100	212	112	35	290	345	28	22	20	13,7	SNL 519-616 SNL 519-616 SNL 519-616 SNL 316 TURU	TSN 316 A TSN 316 S TSN 316 ND included	ASNH 519-616 ASNH 519-616 ASNH 519-616 ASNH 519-616 R

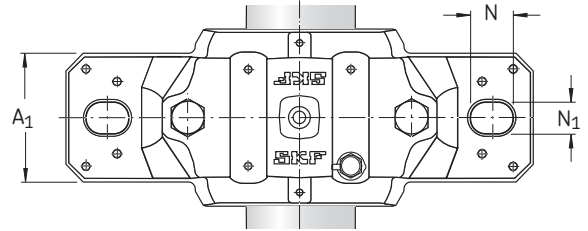
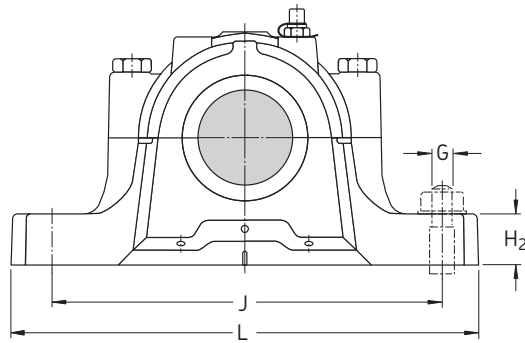
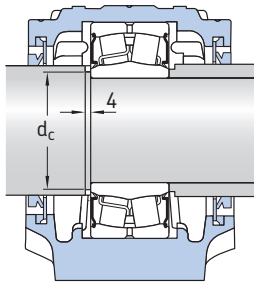

Housing with a sealed spherical roller bearing

Shaft				Bearing seat		Width across seals			Appropriate bearings and associated components					
d_a	d_b	$d_c^{1)}$ min	$d_c^{1)}$ max	C_a	D_a	A_2	A_3	A_4	Self-aligning ball bearing	Locating rings 2 per housing	Self-aligning ball bearing	Spherical roller bearing	Sealed spherical roller bearing	Locating rings 2 per housing
mm	mm	mm	mm	mm	mm	mm	mm	mm	–	–	–	–	–	–
65	75	–	–	51	120	128	190	–	1213 –	ETN9 –	FRB 14/120 –	2213 22213 E BS2-2213-2CS/VT143 C 2213 TN9	FRB 10/120 FRB 10/120 FRB 6.5/120 FRB 10/120	
	75	–	–	58	140	138	200	141	1313 21313 E	–	FRB 12.5/140 FRB 12.5/140	2313 22313 E – –	FRB 5/140 FRB 5/140 – –	
70	80	–	–	61	150	143	205	143	1314 21314 E	–	FRB 13/150 FRB 13/150	2314 22314 E – C 2314	FRB 5/150 FRB 5/150 – FRB 5/150	
	85	84	84	56	130	133	195	–	1215 –	–	FRB 15.5/130 –	2215 ETN9 22215 E BS2-2215-2CS/VT143²⁾ C 2215	FRB 12.5/130 FRB 12.5/130 FRB 9/130 FRB 12.5/130	
75	85	–	–	65	160	158	220	159	1315 21315 E	–	FRB 14/160 FRB 14/160	2315 22315 E – C 2315	FRB 5/160 FRB 5/160 – FRB 5/160	
	90	–	–	58	140	138	200	–	1216 –	–	FRB 16/140	2216 ETN9 22216 E BS2-2216-2CS/VT143 C 2216	FRB 12.5/140 FRB 12.5/140 FRB 9/140 FRB 12.5/140	
80	90	–	–	68	170	163	218	166	1316 21316 E	–	FRB 14.5/170 FRB 14.5/170	2316 22316 E – C 2316	FRB 5/170 FRB 5/170 – FRB 5/170	

¹⁾ Valid for some sealed spherical roller bearings only
²⁾ The shaft must be modified according to d_c values for the bearing

SNL plummer block housings for bearings with a cylindrical bore

d_a 85 – 130 mm

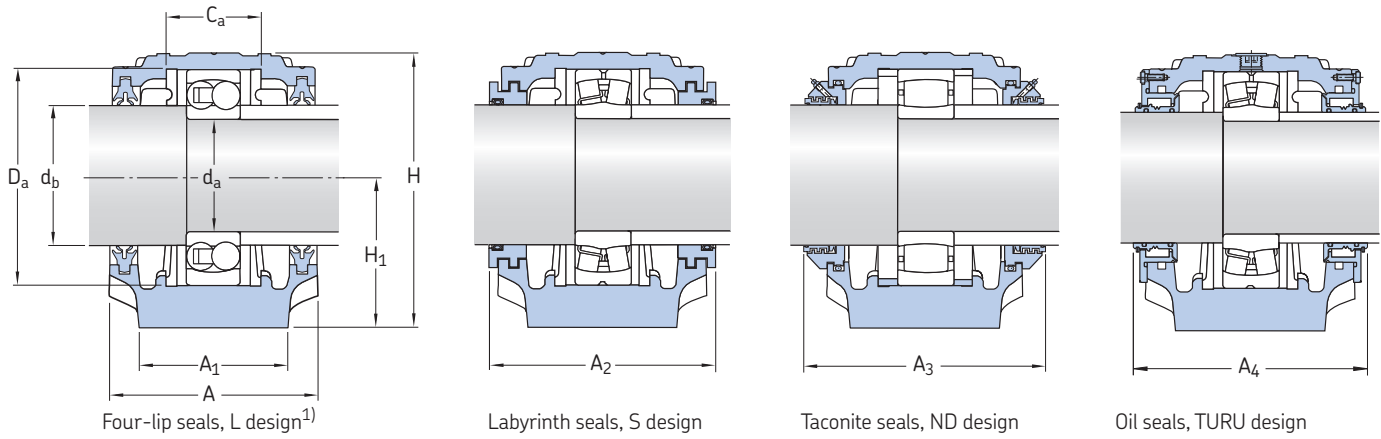

Shaft d_a	Housing Dimensions										Mass	Designations		
	A	A ₁	H	H ₁	H ₂	J	L	N	N ₁	G		Housing	Seals	End cover
mm	mm										kg	-		
85	125	90	183	95	32	260	320	28	22	20	9,50	SNL 217 SNL 517 SNL 217 SNL 217	TSN 217 A 4 FS 170 TSN 217 S TSN 217 ND	ASNH 217 ASNH 517 ASNH 217 ASNH 217
	160	110	218	112	40	320	380	32	26	24	17,6	SNL 520-617 SNL 520-617 SNL 520-617 SNL 317 TURU	TSN 317 A TSN 317 S TSN 317 ND included	ASNH 520-617 ASNH 520-617 ASNH 520-617 ASNH 520-617 R
90	140	100	194	100	35	290	345	28	22	20	11,8	SNL 218 SNL 218 SNL 518-615 SNL 218 SNL 218	TSN 218 L TSN 218 A 4 FS 170 TSN 218 S TSN 218 ND	ASNH 218 ASNH 218 ASNH 518-615 ASNH 218 ASNH 218
	175	120	242	125	45	350	410	32	26	24	22,0	SNL 522-619 SNL 522-619 SNL 522-619 SNL 319 TURU	TSN 319 A TSN 319 S TSN 319 ND included	ASNH 522-619 ASNH 522-619 ASNH 522-619 ASNH 522-619 R
100	160	110	218	112	40	320	380	32	26	24	17,6	SNL 520-617 SNL 520-617 SNL 520-617 SNL 520-617	TSN 220 L TSN 220 A TSN 220 S TSN 220 ND	ASNH 520-617 ASNH 520-617 ASNH 520-617 ASNH 520-617
	185	120	271	140	45	350	410	32	26	24	26,2	SNL 524-620 SNL 524-620 SNL 524-620 SNL 320 TURU	TSN 320 A TSN 320 S TSN 320 ND included	ASNH 524-620 ASNH 524-620 ASNH 524-620 ASNH 524-620 R
110	175	120	242	125	45	350	410	32	26	24	22,0	SNL 522-619 SNL 522-619 SNL 522-619 SNL 522-619	TSN 222 L TSN 222 A TSN 222 S TSN 222 ND	ASNH 522-619 ASNH 522-619 ASNH 522-619 ASNH 522-619
	185	120	271	140	45	350	410	32	26	24	26,2	SNL 524-620 SNL 524-620 SNL 524-620 SNL 524-620	TSN 224 L TSN 224 A TSN 224 S TSN 224 ND	ASNH 524-620 ASNH 524-620 ASNH 524-620 ASNH 524-620
130	190	130	290	150	50	380	445	35	28	24	33,0	SNL 526 SNL 526 SNL 526 SNL 526	TSN 226 L TSN 226 A TSN 226 S TSN 226 ND	ASNH 526 ASNH 526 ASNH 526 ASNH 526

¹⁾ Dimension A remains the same also with A seal design

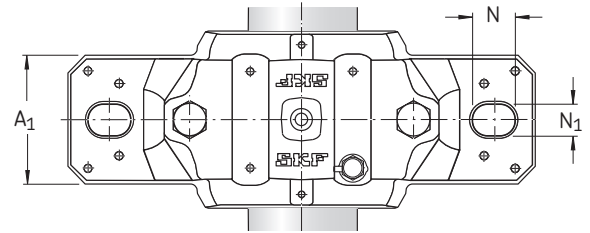
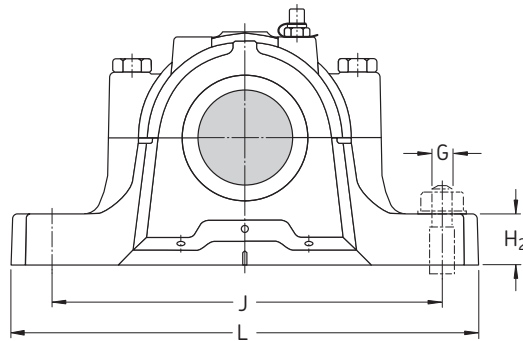
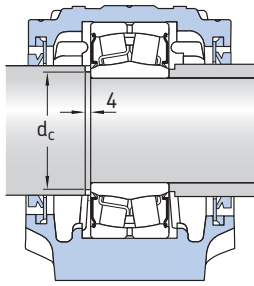

Housing with a sealed spherical roller bearing

Shaft				Bearing seat		Width across seals			Appropriate bearings and associated components			
d_a	d_b	$d_c^{1)}$ min	$d_c^{1)}$ max	C_a	D_a	A_2	A_3	A_4	Self-aligning ball bearing	Locating rings 2 per housing	Self-aligning ball bearing	Locating rings 2 per housing
									Spherical roller bearing		Spherical roller bearing	
									Sealed spherical roller bearing		Sealed spherical roller bearing	
									CARB toroidal roller bearing		CARB toroidal roller bearing	
mm				mm		mm			-			
85	95	-	-	61	150	143	205	-	1217	FRB 16.5/150	2217	FRB 12.5/150
									-	-	22217 E	FRB 12.5/150
									-	-	BS2-2217-2CS/VT143	FRB 8.5/150
									-	-	C 2217	FRB 12.5/150
	95	-	-	70	180	178	238	181	1317	FRB 14.5/180	2317	FRB 5/180
									21317 E	FRB 14.5/180	22317 E	FRB 5/180
									-	-	C 2317	-
									-	-	-	FRB 5/180
90	100	-	-	65	160	158	220	-	1218	FRB 17.5/160	2218	FRB 12.5/160
									23218 CC/W33	FRB 6.25/160	22218 E	FRB 12.5/160
									-	-	BS2-2218-2CS/VT143	FRB 8.5/160
									-	-	C 2218	FRB 12.5/160
95	110	-	-	80	200	191	253	195	1319	FRB 17.5/200	2319 M	FRB 6.5/200
									21319 E	FRB 17.5/200	22319 E	FRB 6.5/200
									-	-	C 2319	FRB 6.5/200
									-	-	-	-
100	115	112	114	70	180	178	245	-	1220	FRB 18/180	2220 M	FRB 12/180
									23220 CC/W33	FRB 4.85/180	22220 E	FRB 12/180
									23220-2CS/VT143	FRB 4.85/180	BS2-2220-2CS5/VT143 ²⁾	FRB 7.5/180
									-	-	C 2220	FRB 12/180
	115	-	-	86	215	199	260	203	1320	FRB 19.5/215	2320 M	FRB 6.5/215
									21320 E	FRB 19.5/215	22320 E	FRB 6.5/215
									-	-	C 2320	-
									-	-	-	FRB 6.5/215
110	125	-	-	80	200	191	255	-	1222	FRB 21/200	2222 M	FRB 13.5/200
									23222 CC/W33	FRB 5.1/200	22222 E	FRB 13.5/200
									-	-	BS2-2222-2CS5/VT143	FRB 8.5/200
									-	-	C 2222	FRB 13.5/200
120	135	-	-	86	215	199	270	-	1224 M	FRB 22/215	-	-
									23224 CC/W33	FRB 5/215	22224 E	FRB 14/215
									-	-	BS2-2224-2CS5/VT143	FRB 8.5/215
									C 3224	FRB 5/215	-	-
130	145	-	-	90	230	208	275	-	1226 M	FRB 22/230	-	-
									23226 CC/W33	FRB 5/230	22226 E	FRB 13/230
									23226-2CS5/VT143	FRB 5/230	BS2-2226-2CS5/VT143	FRB 7.5/230
									-	-	C 2226	FRB 13/230

¹⁾ Valid for some sealed spherical roller bearings only
²⁾ The shaft must be modified according to d_c values for the bearing

SNL plummer block housings for bearings with a cylindrical bore

d_a 140 – 160 mm

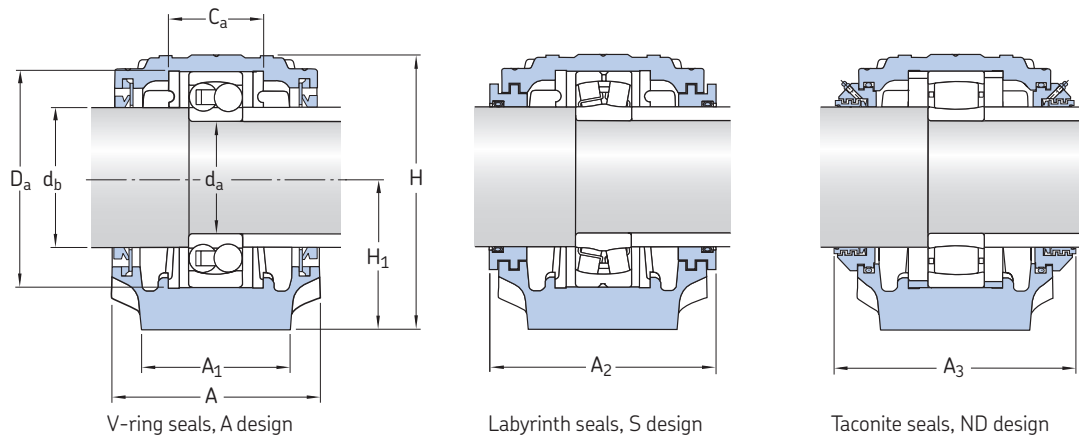

Shaft d_a	Housing Dimensions											Mass	Designations Housing	Seals	End cover
	A	A ₁	H	H ₁	H ₂	J	L	N	N ₁	G					
mm	mm											kg	–		
140	205	150	302	150	50	420	500	42	35	30	40,0	SNL 528	TSN 228 A	ASNH 528	
												SNL 528	TSN 228 S	ASNH 528	
												SNL 528	TSN 228 ND	ASNH 528	
150	220	160	323	160	60	450	530	42	35	30	49,0	SNL 530	TSN 230 A	ASNH 530	
												SNL 530	TSN 230 S	ASNH 530	
												SNL 530	TSN 230 ND	ASNH 530	
160	235	160	344	170	60	470	550	42	35	30	55,0	SNL 532	TSN 232 A	ASNH 532	
												SNL 532	TSN 232 S	ASNH 532	
												SNL 532	TSN 232 ND	ASNH 532	

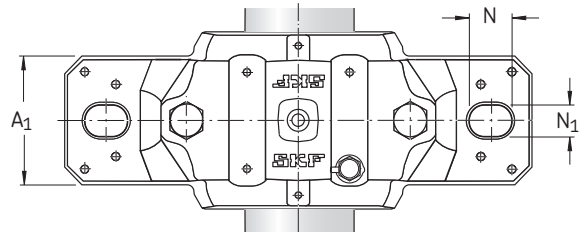
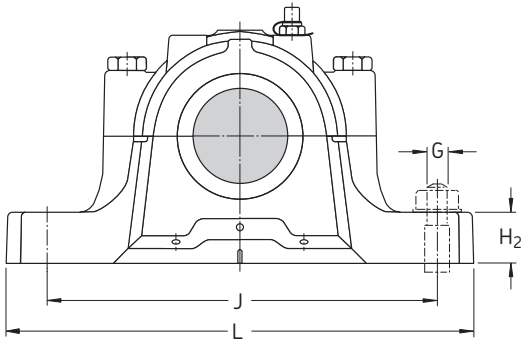

Shaft		Bearing seat		Width across seals		Appropriate bearings and associated components			
d_a	d_b	C_a	D_a	A_2	A_3	Spherical roller bearing	Locating rings	Spherical roller bearing	Locating rings
mm	mm	mm	mm	mm	mm	Sealed spherical roller bearing	2 per housing	Sealed spherical roller bearing	2 per housing
						CARB toroidal roller bearing		CARB toroidal roller bearing	
140	155	98	250	223	290	23228 CC/W33 23228-2CS5/VT143 -	FRB 5/250 FRB 5/250 -	22228 CC/W33 22228-2CS5/VT143 C 2228	FRB 15/250 FRB 15/250 FRB 15/250
150	165	106	270	241	310	23230 CC/W33 23230-2CS5/VT143 -	FRB 5/270 FRB 5/270 -	22230 CC/W33 22230-2CS5/VT143 C 2230	FRB 16.5/270 FRB 16.5/270 FRB 16.5/270
160	175	114	290	254	325	23232 CC/W33 - C 3232	FRB 5/290 - FRB 5/290	22232 CC/W33 22232-2CS5/VT143 -	FRB 17/290 FRB 17/290 -

Sealing arrangements for SNL plummer block housings, metric shafts

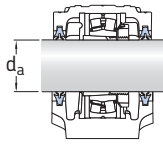

Housing series 5

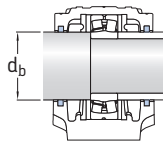

Housing series 2

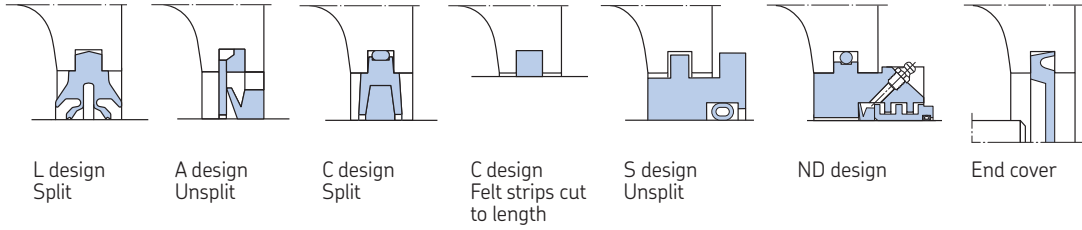

Housing Size	Shaft diameter d_a, d_b	Seal sets L design 2 four-lip seals	A design 2 V-ring seals	Loose V-ring	C design 2 felt seals or loose felt strips	S design 1 labyrinth seal	ND design 1 Taconite seal	End cover
–	mm	–	–	–	–	–	–	–
505	20 30	– –	TSN 505 A –	CR 400200 –	TSN 505 C 2 × FS 170 ¹⁾	2 × TSN 505 S –	2 × TSN 505 ND	ASNH 505
205	20 25 30 35	– – – –	TSN 605 A TSN 506 A – –	CR 400200 CR 400250 – –	TSN 605 C TSN 506 C – 2 × FS 170 ¹⁾	2 × TSN 605 S 2 × TSN 506 S 2 × TSN 205 S –	2 × TSN 605 ND 2 × TSN 506 ND 2 × TSN 205 ND –	ASNH 506-605
506-605	20 25 30 35	– – – –	TSN 605 A TSN 506 A TSN 205 A –	CR 400200 CR 400250 CR 400300 –	TSN 605 C TSN 506 C – 2 × FS 170 ¹⁾	2 × TSN 605 S 2 × TSN 506 S 2 × TSN 205 S –	2 × TSN 605 ND 2 × TSN 506 ND 2 × TSN 205 ND –	ASNH 506-605
206-305	25 30 35 45	– TSN 507 L – –	TSN 606 A TSN 305 A TSN 206 A –	CR 400250 CR 400300 CR 400350 –	TSN 606 C TSN 305 C – 2 × FS 170 ¹⁾	2 × TSN 606 S 2 × TSN 305 S 2 × TSN 206 S –	2 × TSN 606 ND 2 × TSN 305 ND 2 × TSN 206 ND –	ASNH 507-606
507-606	25 30 35 45	– TSN 507 L – –	TSN 606 A TSN 507 A TSN 306 A –	CR 400250 CR 400300 CR 400350 –	TSN 606 C TSN 507 C – 2 × FS 170 ¹⁾	2 × TSN 606 S 2 × TSN 507 S 2 × TSN 306 S –	2 × TSN 606 ND 2 × TSN 507 ND 2 × TSN 306 ND –	ASNH 507-606
207	40 45 55	TSN 509 L – –	TSN 509 A TSN 207 A –	CR 400400 CR 400450 –	TSN 509 C – 4 × FS 170 ¹⁾	2 × TSN 509 S 2 × TSN 207 S –	2 × TSN 509 ND 2 × TSN 207 ND –	ASNH 509
508-607	30 35 50	– TSN 508 L –	TSN 607 A TSN 508 A –	CR 400300 CR 400350 –	TSN 607 C TSN 508 C 4 × FS 170 ¹⁾	2 × TSN 607 S 2 × TSN 508 S –	2 × TSN 607 ND 2 × TSN 508 ND –	ASNH 508-607
208-307	35 45 50 60	– TSN 510 L – –	TSN 608 A TSN 307 A TSN 208 A –	CR 400350 CR 400450 CR 400500 –	TSN 608 C – – 4 × FS 170 ¹⁾	2 × TSN 608 S 2 × TSN 307 S 2 × TSN 208 S –	2 × TSN 608 ND 2 × TSN 307 ND 2 × TSN 208 ND –	ASNH 510-608
509	40 45 55	TSN 509 L – –	TSN 509 A TSN 307 A –	CR 400400 CR 400450 –	TSN 509 C – 4 × FS 170 ¹⁾	2 × TSN 509 S 2 × TSN 307 S –	2 × TSN 509 ND 2 × TSN 307 ND –	ASNH 509
209	40 50 55 65	TSN 609 L TSN 511 L – –	TSN 609 A TSN 511 A TSN 209 A –	CR 400400 CR 400500 CR 400550 –	TSN 609 C TSN 511 C – 4 × FS 170 ¹⁾	2 × TSN 609 S 2 × TSN 511 S 2 × TSN 209 S –	2 × TSN 609 ND 2 × TSN 511 ND 2 × TSN 209 ND –	ASNH 511-609
510-608	35 45 50 60	– TSN 510 L – –	TSN 608 A TSN 510 A TSN 308 A –	CR 400350 CR 400450 CR 400500 –	TSN 608 C TSN 510 C – 4 × FS 170 ¹⁾	2 × TSN 608 S 2 × TSN 510 S 2 × TSN 308 S –	2 × TSN 608 ND 2 × TSN 510 ND 2 × TSN 308 ND –	ASNH 510-608

¹⁾ Loose felt strips

Housing Size	Shaft diameter d _a , d _b	Seal sets L design 2 four-lip seals	A design 2 V-ring seals	Loose V-ring	C design 2 felt seals or loose felt strips	S design 1 labyrinth seal	ND design 1 Taconite seal	End cover
–	mm	–						–
210	45 55 60 70	TSN 610 L TSN 512 L – –	TSN 610 A TSN 512 A TSN 210 A –	CR 400450 CR 400550 CR 400600 –	TSN 610 C TSN 512 C – 4 × FS 170 ¹⁾	2 × TSN 610 S 2 × TSN 512 S 2 × TSN 210 S –	2 × TSN 610 ND 2 × TSN 512 ND 2 × TSN 210 ND –	ASNH 512-610
511-609	40 50 55 65	TSN 609 L TSN 511 L – –	TSN 609 A TSN 511 A TSN 309 A –	CR 400400 CR 400500 CR 400550 –	TSN 609 C TSN 511 C – 4 × FS 170 ¹⁾	2 × TSN 609 S 2 × TSN 511 S 2 × TSN 309 S –	2 × TSN 609 ND 2 × TSN 511 ND 2 × TSN 309 ND –	ASNH 511-609
211	50 60 65 75	TSN 611 L TSN 513 L – –	TSN 611 A TSN 513 A TSN 211 A –	CR 400500 CR 400600 CR 400650 –	TSN 611 C TSN 513 C – 4 × FS 170 ¹⁾	2 × TSN 611 S 2 × TSN 513 S 2 × TSN 211 S –	2 × TSN 611 ND 2 × TSN 513 ND 2 × TSN 211 ND –	ASNH 513-611
512-610	45 55 60 70	TSN 610 L TSN 512 L – –	TSN 610 A TSN 512 A TSN 310 A –	CR 400450 CR 400550 CR 400600 –	TSN 610 C TSN 512 C – 4 × FS 170 ¹⁾	2 × TSN 610 S 2 × TSN 512 S 2 × TSN 310 S –	2 × TSN 610 ND 2 × TSN 512 ND 2 × TSN 310 ND –	ASNH 512-610
212	55 65 70 85	TSN 612 L TSN 515 L – –	TSN 612 A TSN 515 A TSN 212 A –	CR 400550 CR 400650 CR 400700 –	TSN 612 C TSN 515 C – 4 × FS 170 ¹⁾	2 × TSN 612 S 2 × TSN 515 S 2 × TSN 212 S –	2 × TSN 612 ND 2 × TSN 515 ND 2 × TSN 212 ND –	ASNH 515-612
513-611	50 60 65 75	TSN 611 L TSN 513 L – –	TSN 611 A TSN 513 A TSN 311 A –	CR 400500 CR 400600 CR 400650 –	TSN 611 C TSN 513 C – 4 × FS 170 ¹⁾	2 × TSN 611 S 2 × TSN 513 S 2 × TSN 311 S –	2 × TSN 611 ND 2 × TSN 513 ND 2 × TSN 311 ND –	ASNH 513-611
213	60 70 75 90	TSN 613 L TSN 516 L – –	TSN 613 A TSN 516 A TSN 213 A –	CR 400600 CR 400700 CR 400750 –	TSN 613 C TSN 516 C – 4 × FS 170 ¹⁾	2 × TSN 613 S 2 × TSN 516 S 2 × TSN 213 S –	2 × TSN 613 ND 2 × TSN 516 ND 2 × TSN 213 ND –	ASNH 516-613
515-612	55 65 70 85	TSN 612 L TSN 515 L – –	TSN 612 A TSN 515 A TSN 312 A –	CR 400550 CR 400650 CR 400700 –	TSN 612 C TSN 515 C – 4 × FS 170 ¹⁾	2 × TSN 612 S 2 × TSN 515 S 2 × TSN 312 S –	2 × TSN 612 ND 2 × TSN 515 ND 2 × TSN 312 ND –	ASNH 515-612
215	65 80 85 100	TSN 615 L TSN 518 L – –	TSN 615 A TSN 518 A TSN 215 A –	CR 400650 CR 400800 CR 400850 –	TSN 615 C TSN 518 C – 4 × FS 170 ¹⁾	2 × TSN 615 S 2 × TSN 518 S 2 × TSN 215 S –	2 × TSN 615 ND 2 × TSN 518 ND 2 × TSN 215 ND –	ASNH 518-615
516-613	60 70 75 90	TSN 613 L TSN 516 L – –	TSN 613 A TSN 516 A TSN 313 A –	CR 400600 CR 400700 CR 400750 –	TSN 613 C TSN 516 C – 4 × FS 170 ¹⁾	2 × TSN 613 S 2 × TSN 516 S 2 × TSN 313 S –	2 × TSN 613 ND 2 × TSN 516 ND 2 × TSN 313 ND –	ASNH 516-613

¹⁾ Loose felt strips

Sealing arrangements for SNL plummer block housings, metric shafts

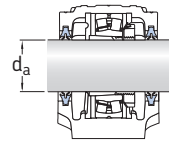

Housing series 5

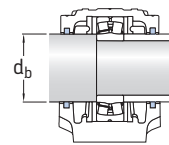

Housing series 2

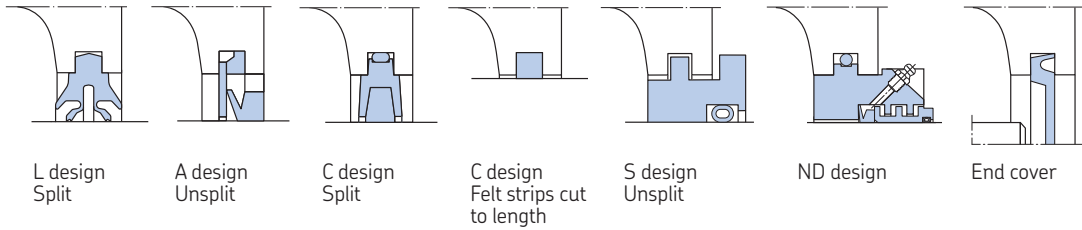

Housing Size	Shaft diameter d_a, d_b	Seal sets L design 2 four-lip seals	A design 2 V-ring seals	Loose V-ring	C design 2 felt seals or loose felt strips	S design 1 labyrinth seal	ND design 1 Taconite seal	End cover
–	mm	–						–
216	90 105	– –	TSN 216 A –	CR 400900 –	– 4 × FS 170 ¹⁾	2 × TSN 216 S –	2 × TSN 216 ND –	ASNH 216
517	75 80 95	TSN 517 L – –	TSN 517 A TSN 314 A –	CR 400750 CR 400800 –	TSN 517 C – 4 × FS 170 ¹⁾	2 × TSN 517 S 2 × TSN 314 S –	2 × TSN 517 ND 2 × TSN 314 ND –	ASNH 517
217	95	–	TSN 217 A	CR 400950	–	2 × TSN 217 S	2 × TSN 217 ND	ASNH 217
518-615	65 80 85 100	TSN 615 L TSN 518 L – –	TSN 615 A TSN 518 A TSN 315 A –	CR 400650 CR 400800 CR 400850 –	TSN 615 C TSN 518 C – 4 × FS 170 ¹⁾	2 × TSN 615 S 2 × TSN 518 S 2 × TSN 315 S –	2 × TSN 615 ND 2 × TSN 518 ND 2 × TSN 315 ND –	ASNH 518-615
218	100	TSN 218 L	TSN 218 A	CR 401000	–	2 × TSN 218 S	2 × TSN 218 ND	ASNH 218
519-616	70 85 90	TSN 616 L TSN 519 L –	TSN 616 A TSN 519 A TSN 316 A	CR 400700 CR 400850 CR 400900	TSN 616 C TSN 519 C –	2 × TSN 616 S 2 × TSN 519 S 2 × TSN 316 S	2 × TSN 616 ND 2 × TSN 519 ND 2 × TSN 316 ND	ASNH 519-616
520-617	75 90 95 115	TSN 617 L TSN 520 L – TSN 220 L	TSN 617 A TSN 520 A TSN 317 A TSN 220 A	CR 400750 CR 400900 CR 400950 CR 401100	TSN 617 C TSN 520 C – –	2 × TSN 617 S 2 × TSN 520 S 2 × TSN 317 S 2 × TSN 220 S	2 × TSN 617 ND 2 × TSN 520 ND 2 × TSN 317 ND 2 × TSN 220 ND	ASNH 520-617
522-619	85 100 110 125	– TSN 522 L – TSN 522 L	TSN 619 A TSN 522 A TSN 319 A TSN 222 A	CR 400850 CR 401000 CR 401100 CR 401300	TSN 619 C TSN 522 C – –	2 × TSN 619 S 2 × TSN 522 S 2 × TSN 319 S 2 × TSN 222 S	2 × TSN 619 ND 2 × TSN 522 ND 2 × TSN 319 ND 2 × TSN 222 ND	ASNH 522-619
524-620	90 110 115 135	– TSN 524 L – TSN 224 L	TSN 620 A TSN 524 A TSN 320 A TSN 224 A	CR 400900 CR 401100 CR 401100 CR 401300	TSN 620 C TSN 524 C – –	2 × TSN 620 S 2 × TSN 524 S 2 × TSN 320 S 2 × TSN 224 S	2 × TSN 620 ND 2 × TSN 524 ND 2 × TSN 320 ND 2 × TSN 224 ND	ASNH 524-620
526	115 145	TSN 526 L TSN 226 L	TSN 526 A TSN 226 A	CR 401100 CR 401500	TSN 526 C –	2 × TSN 526 S 2 × TSN 226 S	2 × TSN 526 ND 2 × TSN 226 ND	ASNH 526
528	125 155	TSN 528 L –	TSN 528 A TSN 228 A	CR 401300 CR 401500	TSN 528 C –	2 × TSN 528 S 2 × TSN 228 S	2 × TSN 528 ND 2 × TSN 228 ND	ASNH 528
530	135 165	TSN 530 L –	TSN 530 A TSN 230 A	CR 401300 CR 401700	TSN 530 C –	2 × TSN 530 S 2 × TSN 230 S	2 × TSN 530 ND 2 × TSN 230 ND	ASNH 530
532	140 175	TSN 532 L –	TSN 532 A TSN 232 A	CR 401400 CR 401700	TSN 532 C –	2 × TSN 532 S 2 × TSN 232 S	2 × TSN 532 ND 2 × TSN 232 ND	ASNH 532

¹⁾ Loose felt strips

Sealing arrangements for SNL plummer block housings, inch shafts

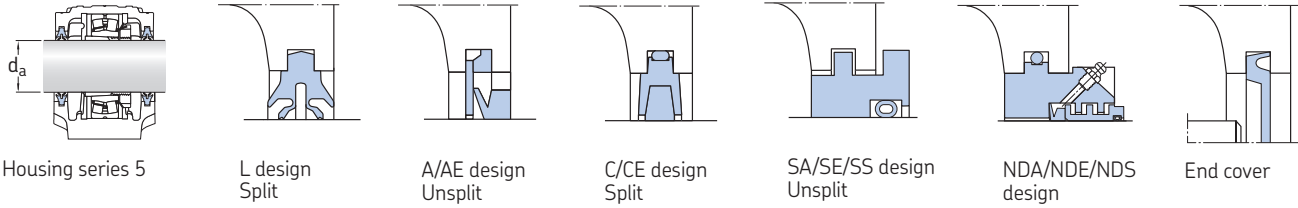

Housing Size	Shaft diameter d_a	Seal sets L/LA design 2 four-lip seals	A/AE design 2 V-ring seals	Loose V-ring	C/CE design 2 felt seals	SA/SE/SS design 1 labyrinth seal	NDA/NDE/NDS design 1 Taconite seal	End cover
–	in	–						–
505	3/4	–	TSN 505 A	CR 400200	TSN 505 C	2 × TSN 505 SE	2 × TSN 505 NDE	ASNH 505
506-605	3/4	–	TSN 605 A	CR 400200	TSN 605 C	2 × TSN 605 SE	2 × TSN 605 NDE	ASNH 506-605
	15/16	–	TSN 605 A	CR 400200	TSN 605 C	2 × TSN 605 SA	2 × TSN 605 NDA	ASNH 506-605
	1	–	TSN 506 A	CR 400250	TSN 506 C	2 × TSN 506 SE	2 × TSN 506 NDE	ASNH 506-605
507-606	15/16	–	TSN 606 A	CR 400250	TSN 606 C	2 × TSN 606 SA	2 × TSN 606 NDA	ASNH 507-606
	1	–	TSN 606 A	CR 400250	TSN 606 C	2 × TSN 606 SE	2 × TSN 606 NDE	ASNH 507-606
	1 1/8	–	TSN 507 A	CR 400300	TSN 507 C	2 × TSN 507 SS	2 × TSN 507 NDS	ASNH 507-606
	1 3/16	TSN 507 L	TSN 507 A	CR 400300	TSN 507 C	2 × TSN 507 SA	2 × TSN 507 NDA	ASNH 507-606
508-607	1 1/8	–	TSN 607 A	CR 400300	TSN 607 C	2 × TSN 607 SS	2 × TSN 607 NDS	ASNH 508-607
	1 3/16	–	TSN 607 A	CR 400300	TSN 607 C	2 × TSN 607 SA	2 × TSN 607 NDA	ASNH 508-607
	1 1/4	–	TSN 508 AE	CR 400320	TSN 508 CE	2 × TSN 508 SE	2 × TSN 508 NDE	ASNH 508-607
	1 3/8	TSN 508 L	TSN 508 A	CR 400350	TSN 508 C	2 × TSN 508 SS	2 × TSN 508 NDS	ASNH 508-607
509	1 7/16	–	TSN 509 AE	CR 400380	TSN 509 CE	2 × TSN 509 SA	2 × TSN 509 NDA	ASNH 509
	1 1/2	–	TSN 509 AE	CR 400380	TSN 509 CE	2 × TSN 509 SE	2 × TSN 509 NDE	ASNH 509
510-608	1 1/4	–	TSN 608 AE	CR 400320	TSN 608 CE	2 × TSN 608 SE	2 × TSN 608 NDE	ASNH 510-608
	1 3/8	–	TSN 608 A	CR 400350	TSN 608 C	2 × TSN 608 SS	2 × TSN 608 NDS	ASNH 510-608
	1 11/16	–	TSN 510 A	CR 400450	TSN 510 C	2 × TSN 510 SA	2 × TSN 510 NDA	ASNH 510-608
	1 3/4	TSN 510 L	TSN 510 A	CR 400450	TSN 510 C	2 × TSN 510 SE	2 × TSN 510 NDE	ASNH 510-608
511-609	1 1/2	–	TSN 609 AE	CR 400380	TSN 609 CE	2 × TSN 609 SE	2 × TSN 609 NDE	ASNH 511-609
	1 7/16	–	TSN 609 AE	CR 400380	TSN 609 CE	2 × TSN 609 SA	2 × TSN 609 NDA	ASNH 511-609
	1 15/16	TSN 511 L	TSN 511 A	CR 400500	TSN 511 C	2 × TSN 511 SA	2 × TSN 511 NDA	ASNH 511-609
	2	TSN 511 L	TSN 511 A	CR 400500	TSN 511 C	2 × TSN 511 SE	2 × TSN 511 NDE	ASNH 511-609
512-610	1 11/16	–	TSN 610 A	CR 400450	TSN 610 C	2 × TSN 610 SA	2 × TSN 610 NDA	ASNH 512-610
	1 3/4	TSN 610 L	TSN 610 A	CR 400450	TSN 610 C	2 × TSN 610 SE	2 × TSN 610 NDE	ASNH 512-610
	2 1/8	–	TSN 512 A	CR 400550	TSN 512 C	2 × TSN 512 SS	2 × TSN 512 NDS	ASNH 512-610
513-611	1 15/16	TSN 611 L	TSN 611 A	CR 400500	TSN 611 C	2 × TSN 611 SA	2 × TSN 611 NDA	ASNH 513-611
	2	TSN 611 L	TSN 611 A	CR 400500	TSN 611 C	2 × TSN 611 SE	2 × TSN 611 NDE	ASNH 513-611
	2 3/16	TSN 513 LA	TSN 513 AE	CR 400550	TSN 513 CE	2 × TSN 513 SA	2 × TSN 513 NDA	ASNH 513-611
	2 1/4	–	TSN 513 A	CR 400600	TSN 513 CE	2 × TSN 513 SE	2 × TSN 513 NDE	ASNH 513-611
515-612	2 1/8	–	TSN 612 A	CR 400550	TSN 612 C	2 × TSN 612 SS	2 × TSN 612 NDS	ASNH 515-612
	2 7/16	TSN 515 LA	TSN 515 AE	CR 400600	TSN 515 CE	2 × TSN 515 SA	2 × TSN 515 NDA	ASNH 515-612
	2 1/2	–	TSN 515 A	CR 400650	TSN 515 C	2 × TSN 515 SE	2 × TSN 515 NDE	ASNH 515-612
516-613	2 3/16	–	TSN 613 AE	CR 400550	TSN 613 CE	2 × TSN 613 SA	2 × TSN 613 NDA	ASNH 516-613
	2 1/4	–	TSN 613 A	CR 400600	TSN 613 CE	2 × TSN 613 SE	2 × TSN 613 NDE	ASNH 516-613
	2 11/16	–	TSN 516 A	CR 400700	TSN 516 C	2 × TSN 516 SA	2 × TSN 516 NDA	ASNH 516-613
	2 3/4	TSN 516 L	TSN 516 A	CR 400700	TSN 516 C	2 × TSN 516 SE	2 × TSN 516 NDE	ASNH 516-613

Housing Size	Shaft diameter d_a	Seal sets L/LA design 2 four-lip seals	A/AE design 2 V-ring seals	Loose V-ring	C/CE design 2 felt seals	SA/SE/SS design 1 labyrinth seal	NDA/NDE/NDS design 1 Taconite seal	End cover
–	in	–						–
517	2 ¹⁵ / ₁₆ 3	TSN 517 L TSN 517 L	TSN 517 A TSN 517 A	CR 400750 CR 400750	TSN 517 C TSN 517 C	2 × TSN 517 SA 2 × TSN 517 SE	2 × TSN 517 NDA 2 × TSN 517 NDE	ASNH 517 ASNH 517
518-615	2 ⁷ / ₁₆ 2 ¹ / ₂ 3 ³ / ₁₆ 3 ¹ / ₄	– – TSN 518 L TSN 518 L	TSN 615 AE TSN 615 A TSN 518 A TSN 518 A	CR 400600 CR 400650 CR 400800 CR 400800	TSN 615 CE TSN 615 C TSN 518 CE TSN 518 CE	2 × TSN 615 SA 2 × TSN 615 SE 2 × TSN 518 SA 2 × TSN 518 SE	2 × TSN 615 NDA 2 × TSN 615 NDE 2 × TSN 518 NDA 2 × TSN 518 NDE	ASNH 518-615 ASNH 518-615 ASNH 518-615 ASNH 518-615
519-616	2 ¹¹ / ₁₆ 2 ³ / ₄	– TSN 616 L	TSN 616 A TSN 616 A	CR 400700 CR 400700	TSN 616 C TSN 616 C	2 × TSN 616 SA 2 × TSN 616 SE	2 × TSN 616 NDA 2 × TSN 616 NDE	ASNH 519-616 ASNH 519-616
520-617	2 ¹⁵ / ₁₆ 3 3 ⁷ / ₁₆ 3 ¹ / ₂	TSN 617 L TSN 617 L – –	TSN 617 A TSN 617 A TSN 520 A TSN 520 A	CR 400750 CR 400750 CR 400900 CR 400900	TSN 617 C TSN 617 C TSN 520 C TSN 520 C	2 × TSN 617 SA 2 × TSN 617 SE 2 × TSN 520 SA 2 × TSN 520 SE	2 × TSN 617 NDA 2 × TSN 617 NDE 2 × TSN 520 NDA 2 × TSN 520 NDE	ASNH 520-617 ASNH 520-617 ASNH 520-617 ASNH 520-617
522-619	3 ¹ / ₄ 3 ¹⁵ / ₁₆ 4	– TSN 522 L TSN 522 L	TSN 619 A TSN 522 A TSN 522 A	CR 400850 CR 401000 CR 401000	TSN 619 C TSN 522 C TSN 522 C	2 × TSN 619 SE 2 × TSN 522 SA 2 × TSN 522 SE	2 × TSN 619 NDE 2 × TSN 522 NDA 2 × TSN 522 NDE	ASNH 522-619 ASNH 522-619 ASNH 522-619
524-620	3 ⁷ / ₁₆ 3 ¹ / ₂ 4 ³ / ₁₆ 4 ¹ / ₄	– – – –	TSN 620 A TSN 620 A TSN 524 A TSN 524 A	CR 400900 CR 400900 CR 401100 CR 401100	TSN 620 C TSN 620 C TSN 524 CE TSN 524 C	2 × TSN 620 SA 2 × TSN 620 SE 2 × TSN 524 SA 2 × TSN 524 SE	2 × TSN 620 NDA 2 × TSN 620 NDE 2 × TSN 524 NDA 2 × TSN 524 NDE	ASNH 524-620 ASNH 524-620 ASNH 524-620 ASNH 524-620
526	4 ⁷ / ₁₆ 4 ¹ / ₂	– TSN 526 L	TSN 526 A TSN 526 A	CR 401100 CR 401100	TSN 526 C TSN 526 C	2 × TSN 526 SA 2 × TSN 526 SE	2 × TSN 526 NDA 2 × TSN 526 NDE	ASNH 526 ASNH 526
528	4 ¹⁵ / ₁₆ 5	TSN 528 L –	TSN 528 A TSN 528 A	CR 401300 CR 401300	TSN 528 C TSN 528 C	2 × TSN 528 SA 2 × TSN 528 SE	2 × TSN 528 NDA 2 × TSN 528 NDE	ASNH 528 ASNH 528
530	5 ³ / ₁₆ 5 ¹ / ₄	– –	TSN 530 A TSN 530 A	CR 401300 CR 401300	TSN 530 C TSN 530 C	2 × TSN 530 SA 2 × TSN 530 SE	2 × TSN 530 NDA 2 × TSN 530 NDE	ASNH 530 ASNH 530
532	5 ⁷ / ₁₆ 5 ¹ / ₂	– TSN 532 L	TSN 532 A TSN 532 A	CR 401400 CR 401400	TSN 532 C TSN 532 C	2 × TSN 532 SA 2 × TSN 532 SE	2 × TSN 532 NDA 2 × TSN 532 NDE	ASNH 532 ASNH 532

Other products for trouble-free operation

High-performance, self-aligning standard rolling bearings

To match the high performance of the SNL plummer block housings, SKF also manufactures state-of-the-art self-aligning rolling bearings:

- Self-aligning ball bearings.
- Spherical roller bearings.
- CARB toroidal roller bearings.

They are available in many sizes and several designs.

The degree of bearing misalignment that can be accommodated depends on the bearing series and also on the seals used in the SNL housings.

Self-aligning ball bearings and spherical roller bearings can be used for both locating and non-locating bearing arrangements. At

non-locating positions, the bearing outer ring is free to move axially in its seating in the housing bore. CARB toroidal roller bearings, on the other hand, accommodate axial displacements within the bearing and are always non-locating. It is common practice to combine a CARB toroidal roller bearing on the non-locating side with a spherical roller bearing or self-aligning ball bearing on the locating side.

Self-aligning ball bearings

Self-aligning ball bearings in the 12, 22, 13 and 23 series can be incorporated in SNL plummer block housings. Sealed self-aligning ball bearings in the 22-2RS1 series are also appropriate, particularly where the surroundings in which the plummer blocks are to operate are heavily contaminated. Self-aligning ball bearings are available with a tapered bore for mounting on adapter sleeves or with a cylindrical bore.

Spherical roller bearings

Spherical roller bearings in the 222, 232, 213 and 223 series can be incorporated in SNL plummer block housings. Spherical roller bearings are available with a tapered bore for mounting on adapter or withdrawal sleeves, or with a cylindrical bore. Sealed spherical roller bearings in the 22, 32 and 23 Dimension Series can also be incorporated.

CARB toroidal roller bearings

CARB toroidal roller bearings in the C 22, C 23 and C 32 series can be incorporated in SNL plummer block housings.

Although available in a caged as well as a full complement version, it is normally recommended that caged bearings be used in SNL housings. CARB toroidal roller bearings are available with a tapered bore for mounting on an adapter sleeve or a withdrawal sleeve, as well as with a cylindrical bore.



For easy mounting – adapter and withdrawal sleeves

Generally, bearings with a tapered bore that are incorporated in SNL plummer block housings are mounted on straight or stepped shafts by means of an adapter sleeve or, with a withdrawal sleeve on stepped shafts only.

SKF manufactures these sleeves in appropriate sizes for the range of bearings that can be used in SNL housings.

Adapter sleeves are more popular than withdrawal sleeves as they are more versatile and easier to mount.

Adapter sleeves

These are slotted sleeves with a tapered outside diameter. The sizes used with bearings for SNL housings have an external taper of 1:12 and are supplied complete with lock nut and locking washer. Their dimensions are in accordance with ISO 2982-1:1995.

When using adapter sleeves on straight shafts, it is possible to locate the bearing at any position on the shaft and no additional axial location is required.

Withdrawal sleeves

These are also slotted sleeves with a tapered outside diameter. The sizes used with bearings for SNL housings have an external taper of 1:12. Their dimensions are in accordance with ISO 2982-1:1995.

Bearings on withdrawal sleeves must be mounted against a fixed abutment, e.g. a shaft shoulder. The withdrawal sleeve must be secured in position after it has been pressed into the bearing bore by a lock nut or end plate on the shaft. The nuts are not supplied with the sleeves.

More information about

- self-aligning ball bearings (→ General Catalogue 6000)
- spherical roller bearings (→ General Catalogue 6000 and brochure 6100)
- CARB toroidal roller bearings (→ General Catalogue 6000 and brochure 6102)
- bearing sleeves (→ catalogue 6005)



Other products

Lock nuts

SKF lock nuts, also referred to as shaft nuts, are available in several designs to axially locate bearings on shaft ends. The most popular are those in the KM, KML and HM series. These nuts have four or eight equally spaced slots in the outside diameter and are locked in position with locking washers or locking clips engaging a groove in the shaft. The nut dimensions are in accordance with ISO 2982-2:1995, as are the dimensions of the locking washers in the MB and MBL series and locking clips in the MS series.

Other lock nuts produced by SKF include those in the KMT, KMTA, KMK and KMFE series and do not require a groove in the shaft.



Lubricating greases for bearings

Lubrication is a necessity for proper bearing performance. Grease is normally used for applications involving SNL plummer blocks. SKF has put considerable effort into establishing a range of high-quality greases for ball and roller bearing lubrication.

The SKF SYSTEM 24 automatic lubricator can also be used with SNL plummer block housings. An adapter can be fitted to the standard drilled and tapped hole in the housing cap. It should be remembered that surplus grease should be able to leave the housing (→ section "Grease lubrication" on **pages 28 and 29**).

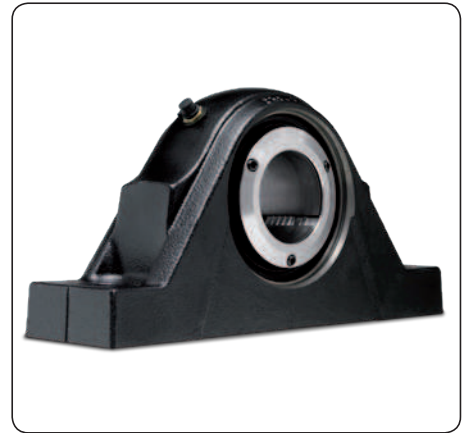

SKF ConCentra roller bearing units

These units are plummer blocks with factory-lubricated bearings for easy installation. They comprise

- a one-piece plummer block housing of grey cast iron
- a spherical roller bearing in the 222 series with special inner ring
- a special adapter sleeve
- two seals of acrylonitrile-butadiene rubber double lip type or two labyrinth seals.

The units are available in a locating and a non-locating version.



Other bearing housings

To meet a wide variety of application demands, SKF produces a comprehensive range of bearing housings. The majority of these are of the split plummer block type but the SKF range also includes

- one-piece plummer block housings
- flanged housings
- take-up housings
- two-bearing housings.

Most of these housings are designed to take self-aligning bearings, and the range extends to shaft diameters up to and including 1 800 mm. Housings are available for oil lubrication as well as grease lubrication and also for bearings with a cylindrical or tapered

bore, mounted on adapter or withdrawal sleeves. Straight or stepped shafts can be used.

Various types of seals are used. Most housings are made of grey cast iron but spheroidal graphite cast iron or cast steel housings are included in the range.

For additional information, contact SKF.

More information about

- lock nuts (→ catalogue 6006)
- greases (→ catalogue MP3000)
- SKF ConCentra roller bearing units (→ brochure 6103)
- housings (→ catalogue 6004)

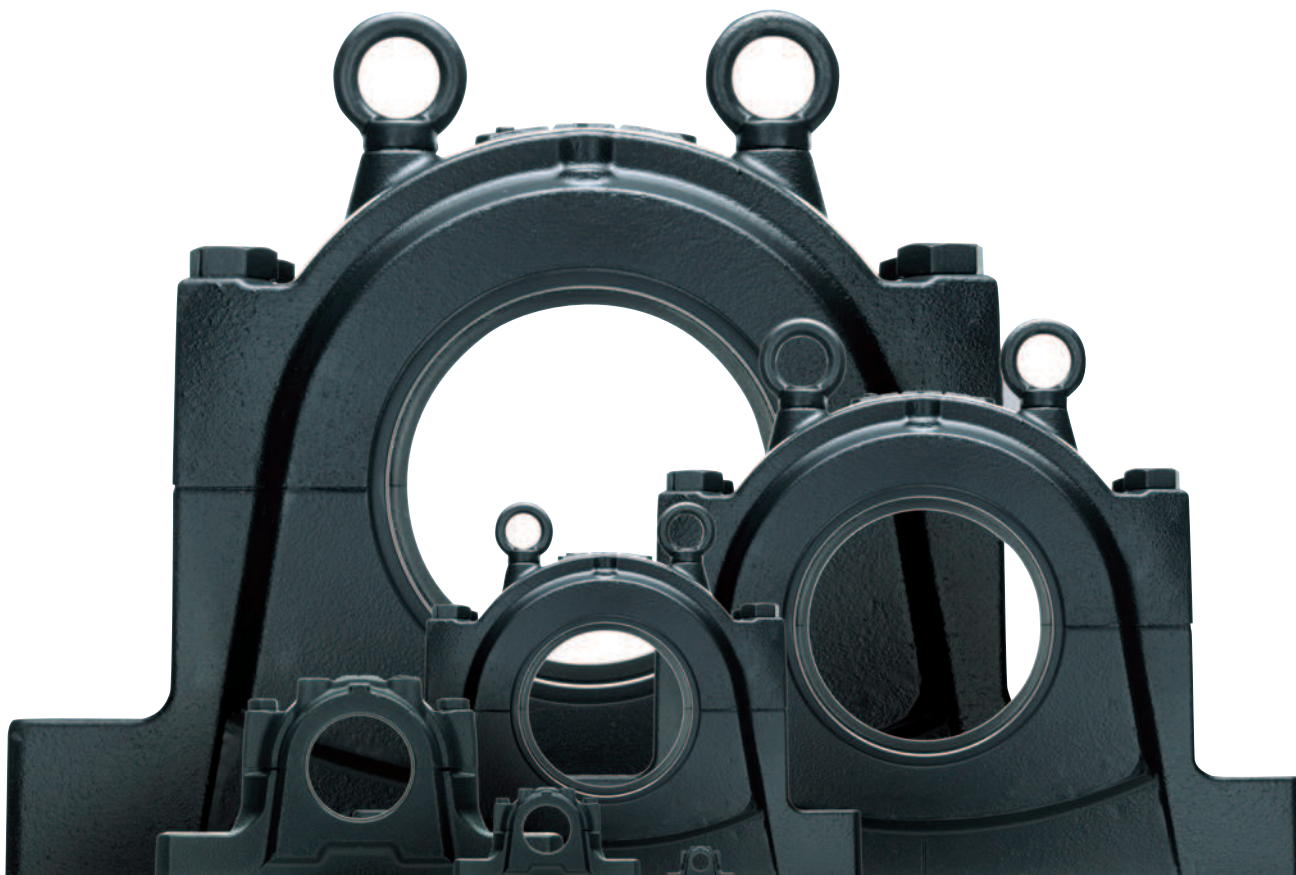

Condition monitoring equipment

The goals of condition monitoring are to maximize the time that the machine is correctly functioning and to minimize the number of breakdowns, thereby significantly reducing operating downtime and maintenance costs.

To achieve this, it is recommended that the bearing and machine condition be monitored either periodically or continuously. Condition monitoring enables incipient bearing damage to be detected and evaluated, so that bearing replacement can be scheduled for a time when the machine is not in operation, thus avoiding unplanned stoppages. Applied to all machinery (not just sensitive or problematic machines), condition monitoring improves machinery operation to an optimum level, often exceeding the original equipment specifications.

SKF provides a comprehensive range of condition monitoring equipment to measure all important parameters. These include

- temperature
- speed
- noise
- oil condition
- shaft alignment
- vibration
- bearing condition.

The range includes lightweight, handheld devices for manual use as well as complex continuous monitoring systems for fixed installations in connection with preventive maintenance.

One example is the MARLIN I-Pro data manager, which is a rugged, high performance data collector that enables plant operations personnel to quickly and easily collect, store and analyze overall machine vibration, process and inspection data. The unit enables trending, comparison with previous readings, alarm alerts and more. A “user notes” feature allows an operator to immediately record detailed observations of troublesome machine conditions or questionable measurements.



Recording vibration values using an SKF Microlog series data collector

SKF Machine Condition Adviser



Noise testing



MARLIN I-Pro data manger





SKF – the knowledge engineering company

From the company that invented the self-aligning ball bearing more than 100 years ago, SKF has evolved into a knowledge engineering company that is able to draw on five technology platforms to create unique solutions for its customers. These platforms include bearings, bearing units and seals, of course, but extend to other areas including: lubricants and lubrication systems, critical for long bearing life in many applications; mechatronics that combine mechanical and electronics knowledge into systems for more effective linear motion and sensorized solutions; and a full range of services, from design and logistics support to condition monitoring and reliability systems.

Though the scope has broadened, SKF continues to maintain the world's leadership in the design, manufacture and marketing of rolling bearings, as well as complementary products such as radial seals. SKF also holds an increasingly important position in the market for linear motion products, high-precision aerospace bearings, machine tool spindles and plant maintenance services.

The SKF Group is globally certified to ISO 14001, the international standard for environmental management, as well as OHSAS 18001, the health and safety management standard. Individual divisions have been approved for quality certification in accordance with ISO 9001 and other customer specific requirements.

With over 100 manufacturing sites worldwide and sales companies in 70 countries, SKF is a truly international corporation. In addition, our distributors and dealers in some 15 000 locations around the world, an e-business marketplace and a global distribution system put SKF close to customers for the supply of both products and services. In essence, SKF solutions are available wherever and whenever customers need them. Overall, the SKF brand and the corporation are stronger than ever. As the knowledge engineering company, we stand ready to serve you with world-class product competencies, intellectual resources, and the vision to help you succeed.



© Airbus – photo: e'm company, H. Goussé

Evolving by-wire technology

SKF has a unique expertise in the fast-growing by-wire technology, from fly-by-wire, to drive-by-wire, to work-by-wire. SKF pioneered practical fly-by-wire technology and is a close working partner with all aerospace industry leaders. As an example, virtually all aircraft of the Airbus design use SKF by-wire systems for cockpit flight control.

SKF is also a leader in automotive by-wire technology, and has partnered with automotive engineers to develop two concept cars, which employ SKF mechatronics for steering and braking. Further by-wire development has led SKF to produce an all-electric forklift truck, which uses mechatronics rather than hydraulics for all controls.

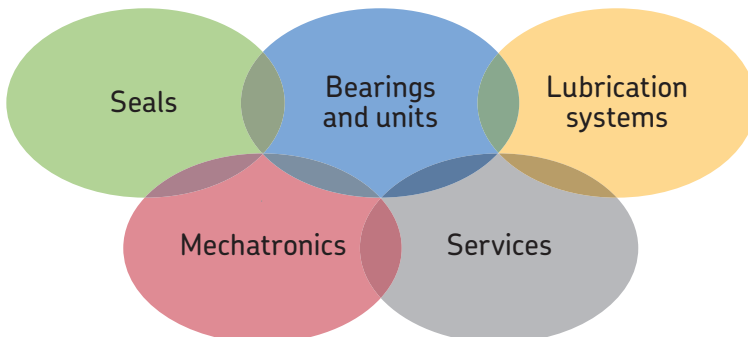



Harnessing wind power

The growing industry of wind-generated electric power provides a source of clean, green electricity. SKF is working closely with global industry leaders to develop efficient and trouble-free turbines, providing a wide range of large, highly specialized bearings and condition monitoring systems to extend equipment life of wind farms located in even the most remote and inhospitable environments.



Working in extreme environments

In frigid winters, especially in northern countries, extreme sub-zero temperatures can cause bearings in railway axleboxes to seize due to lubrication starvation. SKF created a new family of synthetic lubricants formulated to retain their lubrication viscosity even at these extreme temperatures. SKF knowledge enables manufacturers and end user customers to overcome the performance issues resulting from extreme temperatures, whether hot or cold. For example, SKF products are at work in diverse environments such as baking ovens and instant freezing in food processing plants.



Developing a cleaner cleaner

The electric motor and its bearings are the heart of many household appliances. SKF works closely with appliance manufacturers to improve their products' performance, cut costs, reduce weight, and reduce energy consumption. A recent example of this cooperation is a new generation of vacuum cleaners with substantially more suction. SKF knowledge in the area of small bearing technology is also applied to manufacturers of power tools and office equipment.



Maintaining a 350 km/h R&D lab

In addition to SKF's renowned research and development facilities in Europe and the United States, Formula One car racing provides a unique environment for SKF to push the limits of bearing technology. For over 60 years, SKF products, engineering and knowledge have helped make Scuderia Ferrari a formidable force in F1 racing. (The average racing Ferrari utilizes around 150 SKF components.) Lessons learned here are applied to the products we provide to automakers and the aftermarket worldwide.



Delivering Asset Efficiency Optimization

Through SKF Reliability Systems, SKF provides a comprehensive range of asset efficiency products and services, from condition monitoring hardware and software to maintenance strategies, engineering assistance and machine reliability programmes. To optimize efficiency and boost productivity, some industrial facilities opt for an Integrated Maintenance Solution, in which SKF delivers all services under one fixed-fee, performance-based contract.



Planning for sustainable growth

By their very nature, bearings make a positive contribution to the natural environment, enabling machinery to operate more efficiently, consume less power, and require less lubrication. By raising the performance bar for our own products, SKF is enabling a new generation of high-efficiency products and equipment. With an eye to the future and the world we will leave to our children, the SKF Group policy on environment, health and safety, as well as the manufacturing techniques, are planned and implemented to help protect and preserve the earth's limited natural resources. We remain committed to sustainable, environmentally responsible growth.



© SKF, CARB, KMT, KMTA, MARLIN, Microlog, Multilog and SYSTEM 24 are registered trademarks of the SKF Group.

© SKF Group 2010

The contents of this publication are the copyright of the publisher and may not be reproduced (even extracts) unless prior written permission is granted. Every care has been taken to ensure the accuracy of the information contained in this publication but no liability can be accepted for any loss or damage whether direct, indirect or consequential arising out of the use of the information contained herein.

PUB BU/P2 06112/1 EN · April 2010

This publication supersedes publication 4403 E.

Printed in Sweden on environmentally friendly paper.

Certain image(s) used under license from Shutterstock.com.

skf.com